

How to install a heat flux sensor

Tips and tricks to get the most out of your heat flux measurement

Measuring heat flux is a powerful tool to gain insights in processes. You may measure for example how much heat flows through a wall, or to a specimen that must be cooled. Assuming the right sensor is used, installing this sensor correctly, so that it performs a stable measurement and measures the right heat flux (radiative and convective), is a critical step to get the right data. This paper dives into the do's and don'ts when installing a heat flux sensor.

Introduction

Heat flux sensors have a wide variety of applications, from thermal performance analysis of thermal insulation, to monitoring of fouling of pipelines and the health monitoring of pigs. Measuring the heat flux can lead to useful insights in processes and system performance. Assuming the right sensor is used, mounting this sensor correctly, so that it performs a stable measurement and measures the right heat flux (radiative and convective), is a critical step to get the right data.

This paper focuses on sensor installation. What are the do's and don'ts when installing a heat flux sensor; how can you get the best data from your sensor?

General considerations for heat flux measurement

- Use the right sensor for the application.
There are many different models, each with their own temperature- and heat flux range. View our complete [product range of heat flux sensors](#).
- See also our video on YouTube: [how to measure heat flux](#).
- Perform a representative measurement. This starts with choosing the right location, representative of the system to be monitored. Use multiple sensors. Representatives may be reviewed using infrared cameras.

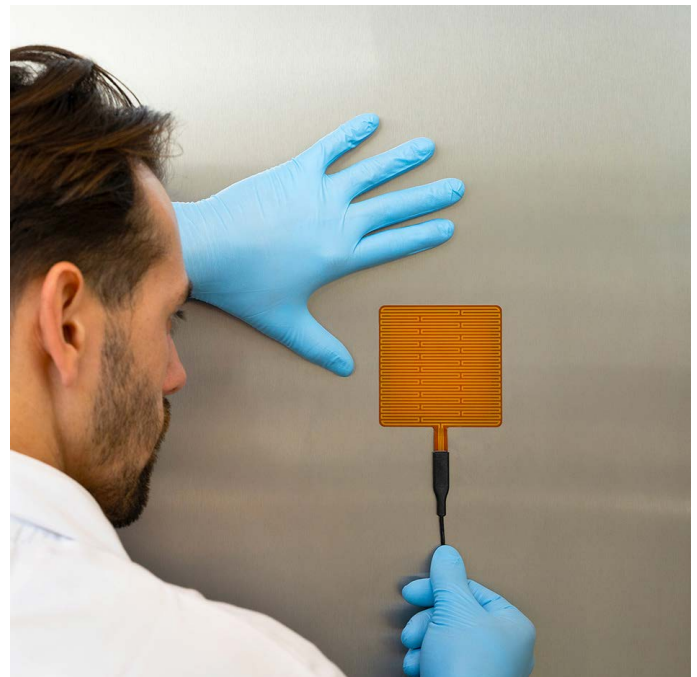

Figure 1 FHF05SC-85X85 Heat flux sensor mounted on a wall, using silicone glue (NR 5 in table 1). NOTE: sensor optical properties do not match those of the metal wall it will later be covered with a metal cover so that optical properties match (NR 4 in table 3).

Considerations for installation

Regardless of the heat flux sensor type, it is important that it is mounted securely to avoid variations of contact resistance between the sensor and the object on which it is mounted.

- Air gaps between sensor and object may be significant thermal resistances and increase response time. This should be avoided.
- Sensors gradually getting loose essentially produce unreliable (unstable) measurements. Use stable glue or filler. Use high quality cabling and strain relief.

Also, optical properties must match.

- Pay attention to the optical properties of the sensor surface. These must match those of the object the sensor is mounted on.

Mounting

There are various ways to mount a heat flux sensor, depending on the application. Two important parameters are

- temperature range
- the duration of the measurement

These two parameters will help choose the right mounting solution for the heat flux sensor.

Table 1 and the examples at the end of this note will help you review your options.

Always ensure strain relief on the cable to avoid unnecessary stress on the sensor.

Why avoid air gaps

The thermal conductivity of air is in the order of $0.02 \text{ W/(m}\cdot\text{K)}$. Therefore, even small air gaps are significant thermal resistances. The thermal conductivity of a plastic or thermal paste is in the order of $0.2 \text{ W/(m}\cdot\text{K)}$, so for the same thickness, thermal resistance is a factor 10 lower. Take for example a $0.05 \times 10^{-3} \text{ m}$, air gap. This has a thermal resistance of $20 \times 10^{-4} \text{ K/(W/m}^2)$. This may be compared to $11 \times 10^{-4} \text{ K/(W/m}^2)$ for FHF05 series or $70 \times 10^{-4} \text{ K/(W/m}^2)$ for HFP01, so a small air gap produces an increase of thermal resistance of 200 % for FHF and about 30 % for HFP01. Using a filler of $0.05 \times 10^{-3} \text{ m}$, with a thermal conductivity around 10 times higher than that of air, the thermal resistance is reduced to $2.5 \times 10^{-4} \text{ K/(W/m}^2)$. The contribution of the thermal resistance reduces to about 20 % for FHF05 and 3 % for HFP01.

From this example you can also see that it is not necessary to use high-thermal conductivity tapes. Using a thin normal tape is enough. An air gap may not only lead to higher thermal resistance for conductive heat, but also to an entirely different radiation balance. An air gap is a "resistance" (a radiation screen) for radiative transfer. If it is filled up, it is no resistance any longer. Watch out in case radiative (far infrared) heat flux is significant. In that case the presence of an air gap may be the dominant source of errors, because a sensor with an air gap acts as a radiation shield, reducing local radiative transfer by a theoretical maximum of 50 %.

Table 1 Options for mounting heat flux sensors. Materials may act to fix the sensor position, but also to fill up airgaps. (continued on next page).

NR	product	duration	rated temperature range	functionality	comments
[#]	[description]	[description]	[°C]	[description]	[description]
1	powerstrip	temporary, easily removable	15 to 40	fixation and gap filling	TESA Powerstrip . Very easily removable.
2	glycerin	minutes	to 120	gap filling only	Filler only for quick experiments; glycerin can be obtained at the local pharmacy. It is safe to use and easily dissolves in water.
3	toothpaste	days	40	gap filling only	Filler only, use with other fixation such as single sided tape. Water-based. Most commercially available toothpastes are suitable.
4	double sided tape	2 weeks, removable	40	fixation and gap filling	TESA 4939 floor laying (carpet) tape combines a high initial bonding power with a residue free removability up to 14 days from the most common surfaces (needs to be tested individually before usage).
5	thermal paste	weeks	to 177	gap filling only	Filler only, use with other fixation such as single sided tape. Silicone oil based. DOW CORNING heat sink compound 340 . OMEGATHERM conductive paste .
6	silicone glue	permanent	-45 to 200	fixation and gap filling	Most commercially available silicone glues are suitable. DOWSIL 3145 silicone sealant .
7	single sided tape	temporary or permanent	-260 to 150	fixation only	Fixation only, use with other fillers such as thermal paste. TESA 51408 orange masking tape . Most commercially available. Kapton tapes are suitable.

8	magnets	temporary or permanent	to 500	fixation only	On magnetic surfaces only. For sensors with optional "frame with magnet" only. In case using welded treads or bolting is not.
9	tack welded threads	temporary or permanent	-260 to 1000	fixation only	For sensors with flanges. Fixation only, use with other fillers such as silicone, graphite sheet material or cement. Usually combined with springs.
10	bolts	temporary or permanent	-260 to 1000	fixation only	For sensors with flanges. Fixation only, use with other fillers such as silicone, graphite sheet material or cement. Usually combined with springs.
11	silicone gasket	temporary or permanent	to 200	gap filling only	Filler only, use with other fixation such as bolts or threads. ERIKS silicone sheet 0.5 mm. Users can cut sheets to size.
12	graphite gasket	temporary or permanent	to 500	gap filling only	Filler only, use with other fixation such as bolts or threads. ERIKS Ergaflex or similar sheet material. Users can cut sheets to size.
13	high temperature cement	temporary or permanent	to 1400	fixation and gap filling	OMEGA high temperature cement.
other options for mounting					
14	cements and epoxies	various	various	various	OMEGA cement and epoxies.

What to do about air gaps

Tapes, sheet (gasket) material, glues, and cements all may be used to fill-up air gaps.

These gaps may occur:

- Because of the nature of the surface. It may not be smooth. Smoothen before installation.
- Because of a curved surface. For all practical purposes, a surface with a radius larger than 5 m is considered “flat”. At smaller radii, use of flexible sensors may be considered. For industrial sensors like IHF01 and IHF02, we may also provide coupling pieces (flat on one side, curved on the other).

Table 1 summarizes the different mounting options.

Why optical properties are important

When heat flux sensors are mounted at a surface, heat will often be transferred by a combination of radiation and convection. For the convective part, the thermal resistance of the sensor should be as low as possible. For the radiative part, the optical surface properties of the sensor should be representative of the surrounding area.

Some points to keep in mind:

- Radiation is not only transmitted in the spectral range that humans can see (visible radiation) but also as non-visible far infrared.
- Blank metal is reflective in the visible as well as in the far infrared.

Paints and plastic coatings wood and stone absorb in different ranges, depending on their color in the visible range. These materials typically all behave as “black” in the far infrared. See figure 2.

To get some feeling how radiative heat transfer works: see Table 2.

To see recommendations on how to adapt the surface optical properties of your sensor: see Table 3.

Representativeness may be reviewed using a combination of normal (visible range) and infrared (far infrared range) cameras.

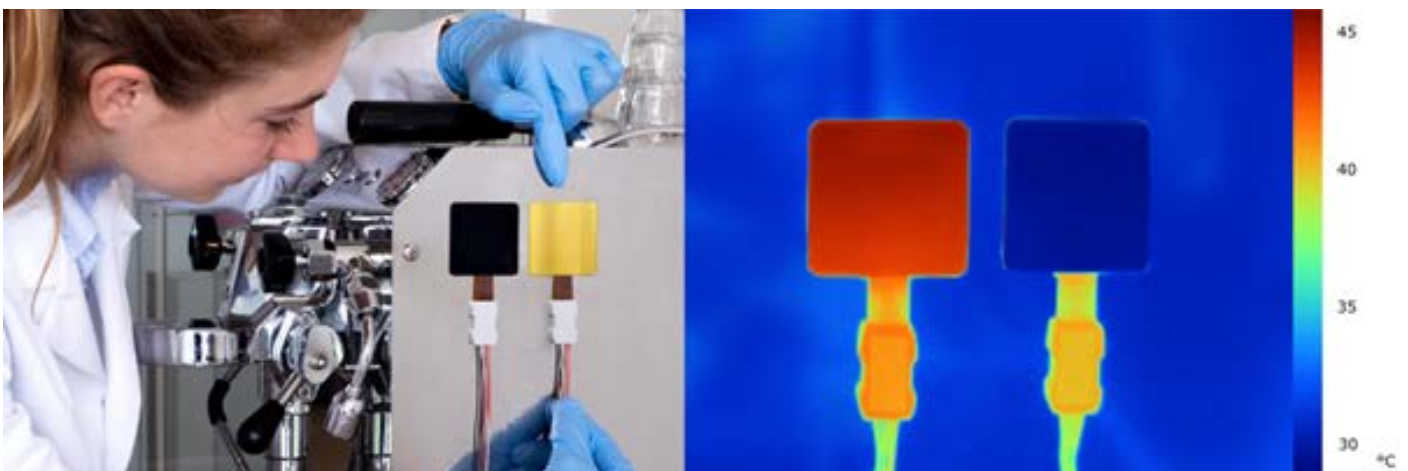

Figure 2 Measuring with BLK – GLD stickers; application of a BLK black sticker and a GLD gold sticker on FHF models for measuring radiative and convective heat flux on an espresso machine. The machine has a polished metal surface of about 45 °C. The IR image on the right shows that the black sticker on the left, as well as the sensor wires and connector blocks, emit radiation. They appear in red on the image. The gold sticker and the metal surface have lower emission and appear as “bluish” on the image. Mounted on the same surface, the BLK and GLD stickers have the same temperature. Measurement with the sensor with the GLD sticker is most representative of the heat flux at the polished metal surface, while the sensor with the BLK sticker overestimates the heat flux.

Table 2 Properties of some common heat flux sources and receiving surfaces. Optical properties of heat flux sensors must match those of the surface they are mounted upon, so that they react in the same way to radiative heat flux.

material/source	visible 0.3 to 0.7 micron	near infrared 0.7 to 0.3 microns	far infrared 3 to 50 microns	examples
sun (blackbody of 7000 °C)	emission	emission	no significant emission	The sun emits radiation in the 0.3 to 3 micron range.
blackbody (-30 to 70 °C)	absorption	absorption	absorption and emission	Objects at normal ambient temperatures emit energy in the far infrared (3 to 50 micron) to their environment.
white object (-30 to 70 °C)	reflection	reflection	absorption and emission	Objects that appear white to the human eye reflect solar radiation but are "black" (behave like blackbodies) in the invisible "far infrared".
colored object (-30 to 70 °C)	partial absorption/ partial reflection	partial absorption	absorption and emission	Objects that are colored to the human eye absorb selectively in the visible range.
blank metal object (all temperatures)	reflection (low emission, low absorption)	reflection (low emission, low absorption)	reflection (low emission, low absorption)	Blank metal reflects and has a low emission. Low emission of far infrared is why thermal insulation systems may have a blank metal cover.

Table 3 What you can do to adapt the surface properties of your heat flux sensor.

NR	material/source	
1	blackbody (-30 to 70 °C)	To create absorbing surfaces you may use tapes like 3M temflex PVC insulation tape
2	white object (-30 to 70 °C)	(rated temperature to 90 °C). BLK black sticker is available for all sensor models of FHF05 series and HFP01 (rated temperature to 150 °C). You may also paint sensor surface paints as used in industry like RUSTOLEUM spray paint (rated temperature to 600 °C). For high temperature black paint
3	colored object (-30 to 70 °C)	RUSTOLEUM Hard hat black or TEMPIL Pyromark 2500 (rated temperature to 650 and 1093 °C respectively).
4	blank metal object (all temperatures)	To create a reflective surface you may use aluminum tapes like 3M 425 tape . Metal sensors like our model IHF01 and IHF02 are already reflective and may be polished on request. GLD gold sticker is available for all sensor models of FHF05 series and HFP01 (rated temperature to 150 °C).

Example 1: HFP01

Heat flux sensor model HFP01 is used a lot on walls to analyze their thermal resistance. For short term installation, thermal paste (typically silicone-oil based) or a water-based paste (toothpaste) can be used to fill up the space between the sensor and the surface. In case of long-term use at one location, the sensor can be installed using double sided tape. Thermal paste is not recommended in this situation because it tends to dry out over time. Choosing double sided tape, make sure the pieces of tape fit neatly next to one another. Apply tape over the entire area of the sensor.



Figure 3 Installation of HFP01 on a wall using 2-sided "removable" carpet laying tape such as TESA 4939 (table 1, NR4) and a strain relief of the cable using a cable tie mount equipped with the same carpet laying tape as adhesive. Note that the optical properties in the visible range do not match those of the surrounding wall. This is acceptable if the heat transfer by visible radiation is negligible, in other words if there is no solar radiation or illumination by strong lamps.

Example 2: IHF02

At high temperatures, above 150 °C, sensors like HFP01 do not survive. For temperatures above 250 °C also the models of the FHF series are not suitable. Industrial heat flux sensors such as model IHF02 are then used. They can withstand up to 100 kW/m² and temperatures up to 900 °C. IHF02 features mounting flanges so that bolts or threads can be used for mounting.

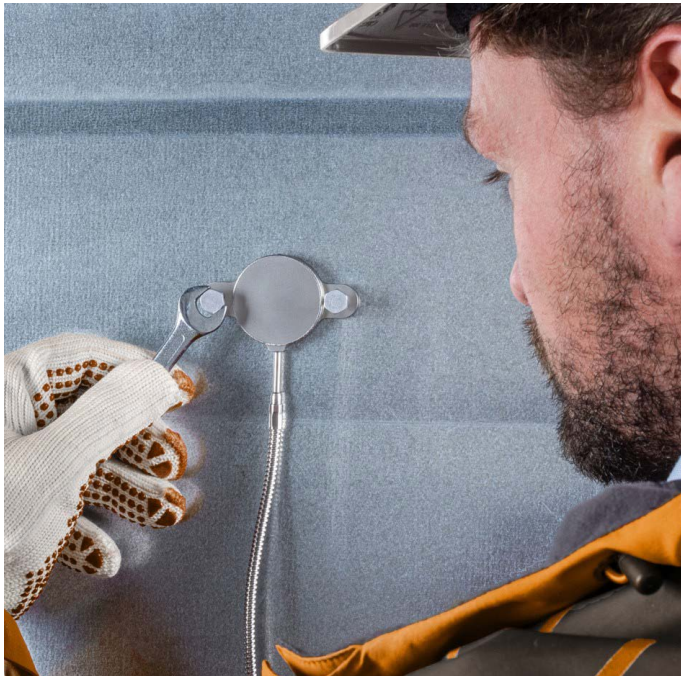

Figure 4 IHF02 industrial heat flux sensor bolted to the surface. Note that the optical properties of sensor and surrounding metal are matching (both blank metal). Springs are not visible.

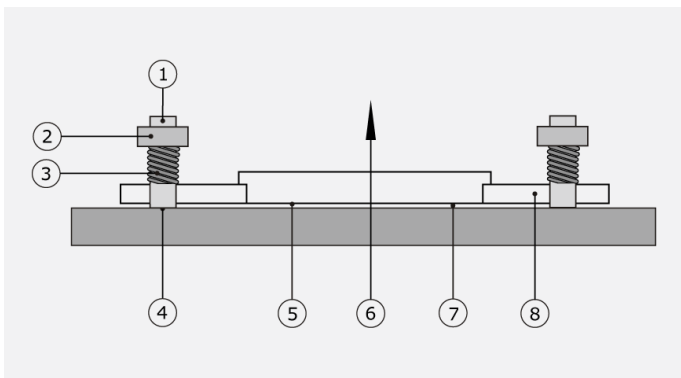

Figure 5 Industrial heat flux (6) sensor (5) mounted using flanges (8) with tack welded (4) threads (1) and spring (3) loaded nuts (2). The space (7) between sensor and object is filled up to avoid air gaps.

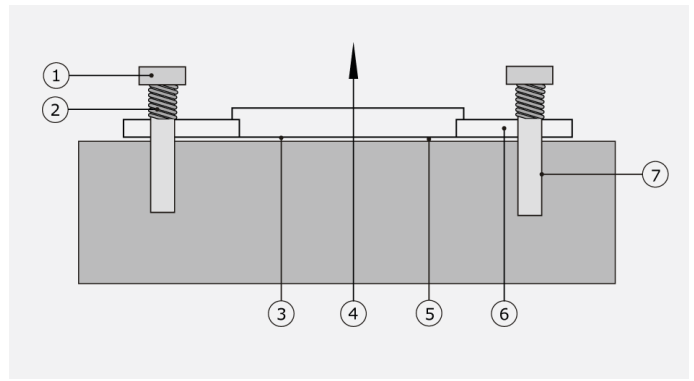

Figure 6 Industrial heat flux (4) sensor (5) mounted using flanges (6) with bolts (1) in tapped holes (7) and spring (2) loading. The space (5) between sensor and object is filled up to avoid air gaps.

Bolts are often combined with springs and air gaps are typically filled up with gasket material or cement. Use of springs ensures constant pressure over a large temperature range and ensures that the pressure on the sensor is not too high.

For short-term installation on magnetic surfaces, consider using a magnet frame. The magnet frame may also be used for long term installation if drilling or welding are not possible.



Figure 7 Mounting of IHF02 using an optional frame with magnets: note that optical properties of the sensor (black) do not match those of the metal object on which the sensor is mounted. This will lead to bad measurement data. (see also figure 3).



Figure 8 IHF02 industrial heat flux sensor with optional frame with magnets.

See also

- our YouTube video: [how to measure heat flux](#)
- video on [how to measure radiation and convection separately](#)
- our complete [heat flux sensor product line](#)

About Hukx

Hukx is the leading expert in measurement of energy transfer. We design and manufacture sensors and measuring systems that support the energy transition. We are market leaders in solar radiation and heat flux measurement. Customers are served worldwide through our headquarters in the Netherlands, and locally owned representative sales offices in the USA, Brazil, India, China, Southeast Asia, and Japan.

Would you like more information?

E-mail us at: info@hukx.com

© Hukx

Version 2505

We reserve the right to change specifications without prior notice.

www.hukx.com

HUKX