

HUKX

Sensor
Technology

User manual
Water-cooled heat flux sensors

SBG series

Cautionary statements

Cautionary statements are subdivided into four categories: danger, warning, caution and notice according to the severity of the risk.

DANGER

Failure to comply with a danger statement will lead to death or serious physical injuries.

WARNING

Failure to comply with a warning statement may lead to risk of death or serious physical injuries.

CAUTION

Failure to comply with a caution statement may lead to risk of minor or moderate physical injuries.

NOTICE

Failure to comply with a notice may lead to damage to equipment or may compromise reliable operation of the instrument.

Contents

Introduction	5
1 Ordering and checking at delivery	9
1.1 Ordering SBG series	9
1.2 Included items	9
1.3 Quick instrument check	9
2 Instrument principle and theory	10
2.1 Detailed measurement equation	11
3 Specifications of SBG series	12
3.2 Dimensions of SBG01	21
3.3 Dimensions of SBG03	22
3.4 Dimensions of SBG04	22
4 Standards and recommended practices for use	23
4.1 Heat flux measurement in fire testing: ISO 14934	23
4.2 SBG04 in cone calorimeter testing: ISO 5660 and ASTM E1354	24
5 Installation of SGB series	25
5.1 Installation in fire testing	25
5.2 Installation in cone calorimeter	26
5.3 Electrical connection	28
5.4 Requirements for data acquisition/amplification	28
5.5 Cooling	29
5.6 Non-cooled sensors	30
6 Making a dependable measurement	31
6.1 Uncertainty evaluation	31
6.2 Contributions to the uncertainty budget	32
7 Maintenance and trouble shooting	33
7.1 Recommended maintenance and quality assurance	33
7.2 Trouble shooting	34
7.3 Recoating/repainting of sensor surfaces	35
8 Appendices	36
8.1 Appendix on cable extension / replacement	36
8.2 Appendix on calibration hierarchy	37
8.3 Appendix on typical heat flux ranges	37
8.4 Appendix on typical SBG series sensitivities	39
8.5 Appendix on sensor design: Gardon versus Schmidt-Boelter	40
8.6 EU declaration of conformity	41

List of symbols

quantities	symbol	unit
heat flux	Φ	W/m ²
voltage output	U	V
sensitivity	S	V/(W/m ²)

subscripts

N/A

Introduction

SBG series are water-cooled sensors that measure heat flux. It is mainly used to test reaction to fire and fire resistance. It is also used as a calibration reference standard for test equipment for example in cone calorimeters, flammability and smoke chamber tests. SBG series complies with the requirements of the most common ASTM and ISO standard test methods.

SBG series measures heat flux in the range of $(5 \text{ to } 200) \times 10^3 \text{ W/m}^2$. Equipped with a black absorber, heat flux sensors of this type are designed for measurement in an environment in which heat flux is dominated by radiation. Using an open detector, SBG series are also sensitive to convective heat flux. This contribution is usually ignored.

Application in environments with lower than $50 \times 10^3 \text{ W/m}^2$ irradiance levels or environments with significant heat transport to the sensor by convection is possible, but requires a careful evaluation of the measurement uncertainty. SBG series' thermopile sensor generates an output voltage proportional to the incoming irradiance.

Using SBG series is easy. It can be connected directly to commonly used data logging systems. The heat flux, Φ , in W/m^2 , is calculated by dividing the SBG output, a small voltage U , by the sensitivity S .

The measurement function of SBG's is:

$$\Phi = U/S \quad (\text{Formula 0.1})$$

The sensitivity is provided with SBG on its product certificate.

The sensor is water-cooled. There are 3 models within the SBG series: each with a different rated measurement range, calibration reference irradiance level, sensitivity and response time. Water-cooling is usually provided by tap water.

SBG01 with a standard body is equipped with a flange. SBG03 has a smooth cylinder body without a flange. SBG04 is mainly used as calibration reference standard for testing with cone calorimeters. All specifications and dimensions are standardized for use in cone calorimeters according to ISO 5660 and ASTM E1354 reaction-to-fire tests. The design includes two water cooling tubes fixed at a 90° angle to the sensor body, with a sensor body of a 0.5 inch diameter.

Next-level technology

SBG series has a novel sensor design, which combines the benefits of foil technology of the traditional Gardon gauges with those of the thermopile technology of the traditional Schmidt-Boelter gauges.

SBG series has several advantages:

- robust and serviceable water tubes
- scratch-resistant absorber coating (slightly lowered surface)
- safe transport and storage with a practical protection cap

Measurement uncertainty

The measurement uncertainty of SBG sensors should be determined on a case-by-case basis. It depends on several factors:

- heat flux sensor properties
- uncertainty of calibration and quality assurance of the local calibration reference standard
- verification of the stability of SBG sensors in day-to-day measurements, before and after use
- application-related uncertainties, for example caused by the unknown contribution of convection and the representativeness of the measurement location

The user should make his own uncertainty evaluation, see the appendix on this subject.

NOTICE

Hukx performs traceable calibrations and is certified according to ISO 9001, but is not an ISO 17025 accredited calibration laboratory.

Figure 1.1 (left) SBG01. Standard cable length is 2 m.

Figure 1.2 (right) SBG01. Protecting the sensing surface is convenient with the practical protection cap.



When the manual addresses the SBG series, this generally applies to all SBG sensor models. In the case that individual models deviate, this is indicated. It is the user's own responsibility to assess whether the information is applicable to their specific model. The recommended calibration interval of heat flux sensors is before and after use.

Calibration

With every SBG sensor, Hukx provides a calibration traceable to a secondary reference standard. The reference has been calibrated by comparison to the primary standard of the **RISE Research Institutes of Sweden AB**.

SBG04 sensors are factory calibrated according to ISO 14934-3. Hukx is ISO 9001 certified but not an ISO /IEC 17025 accredited measurement laboratory.



Figure 1.3 SBG01 is the sensor of choice for fire testing.

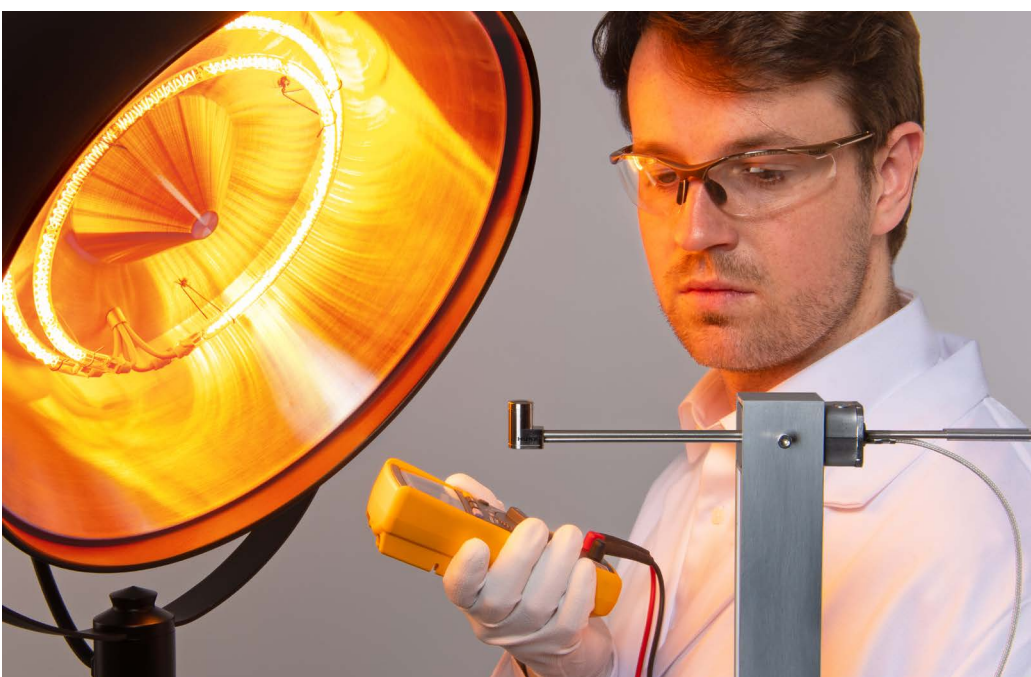

Figure 1.4 SBG04 is the sensor of choice as calibration reference standard for cone calorimeter test equipment, but may also be used for other purposes.

ISO/ASME standardized practices

Calibration and the use of heat flux sensors (officially "heat flux meters") are subject to standardized practices, according to ISO 14934, *Reaction-to-Fire tests — Calibration and use of heat flux meters*. The same procedures will also be adopted by ASTM. In case the user performs accredited testing or works in an accredited organization, the user must comply with these standards.

The ISO 14934 standard has 4 parts:

- Part 1: General principles
- Part 2: Primary calibration methods
- Part 3: Secondary calibration methods
- Part 4: Guidance on use of heat flux meters

The most important requirements are:

- **Secondary reference standards:** You should have 3 local "secondary standard" calibration reference instruments (i.e., sensors calibrated using the primary standard per ISO 14934-2) for calibration of your local "working standards" (i.e., instruments used for daily work and test equipment calibration). Calibration of your reference instruments may be done at NIST (USA), RISE (Sweden), or LNE (France). Of the 3 calibration reference instruments, 2 instruments must remain unused until unexpected results appear or the first calibration reference standard is sent away for recalibration.
- **Periodic recalibration:** Every 2 years, you should calibrate 1 of the reference standards against the primary standard. Then use this instrument to verify the uncertainty of the other 2 calibration reference standards. A single calibration reference sensor is usually calibrated at multiple heat flux levels, allowing it to be used as a reference within that range or at higher levels by extrapolation.
- **Appropriate usage:** You may only use working standards at an irradiance level close to its calibration reference condition.
- **Routine verification:** Before (and preferably after) each test, you should compare working standards to a local calibration reference standard following the method specified in ISO 14934-3. The comparison is done under a local irradiance source, for example, a cone calorimeter.

See also

- **GG01** Gardon gauge water-cooled high heat flux sensor for measurements up to $2500 \times 10^3 \text{ W/m}^2$
- **HFS01** for concentrated solar flames

1 Ordering and checking at delivery

1.1 Ordering SBG series

The standard configuration of SBG series is with 2 meters cable.

Common options are:

- SBG01 standard body with flange
 - rated measurement range (5, 10, 20, 50, 100, 200) x 10³ W/m²
 - longer cable (specify total cable length in m)
- SBG03 smooth cylindrical body without flange
 - rated measurement range (5, 10, 20, 50, 100, 200) x 10³ W/m²
 - longer cable (specify total cable length in m)
 - longer cooling tubes 150 x 10⁻³ m (specify -P150)
- SBG04 Ø12.7 mm (0.5 inch) diameter body with water-cooling tubes at 90 ° angle
 - rated measurement range 100 x 10³ W/m²
 - cable length 2 m

1.2 Included items

Arriving at the customer, the delivery should include:

- heat flux sensor SBG version as ordered
- cable of the length as ordered
- product certificate matching the instrument serial number
- options as ordered

1.3 Quick instrument check

A quick test of the instrument can be done by connecting it to a multimeter.

1. Check the electrical resistance of the sensor between the black [-] and white [+] wires. Use a multimeter at the 100 Ω range. Measure the sensor resistance first with one polarity, then reverse the polarity. Take the average value. The typical resistance of the wiring is 0.1 Ω/m. Typical resistance should be the nominal sensor resistance of 25 Ω for plus 1.5 Ω for the total resistance of two wires (back and forth) of each 2 m. Infinite resistance indicates a broken circuit; zero or a lower than 1 Ω resistance indicates a short circuit.
2. Remove the white removable protection cap from the sensor.
Check if the sensor reacts to heat: put the multimeter at its most sensitive range of DC voltage measurement, typically the 100 x 10⁻³ VDC range or lower. Expose the sensor to heat, for instance, by putting a flame from a consumer-type gas lighter at a distance of around 0.01 m.
The signal should read > 2 x 10⁻³ V now. Do not expose for more than 10 s.
3. Inspect the sensor surface for any damage.
4. Check the sensor serial number against the certificate provided with the sensor.

2

Instrument principle and theory

The SBG heat flux sensor measures radiation received by a plane surface from a 180 ° field of view angle. This quantity, expressed in W/m^2 , is called irradiance, and informally also heat flux. SBG's are designed to measure high heat fluxes, in the order of $5 \times 10^3 W/m^2$ and higher. The radiation spectrum of such sources typically extends from 300 to $3000 \times 10^{-9} m$. By definition, a heat flux sensor should cover that spectral range with a spectral selectivity that is as "flat" as possible. Using an open detector, SBG is also sensitive to convective heat flux. This contribution is usually ignored.

In an irradiance measurement by definition the response to "beam" radiation varies with the cosine of the angle of incidence; i.e. it should have full response when the radiation hits the sensor perpendicularly (normal to the surface, 0 ° angle of incidence), zero response when the radiation has 90 ° angle of incidence, and 50 % of full response at 60 ° angle of incidence. A heat flux sensor should have a so-called "directional response" (older documents mention "cosine response") that is as close as possible to the ideal cosine characteristic.

In order to attain the proper directional and spectral characteristics, a heat flux sensor's main components are:

- a thermal sensor with black coating. It has a flat spectrum covering the 200 to $50000 \times 10^{-9} m$ range, and has a near-perfect directional response. The coating absorbs all radiation and, at the moment of absorption, converts it to heat. The heat flows through the internal thermopile sensor to the metal body. The thermopile sensor generates a voltage output signal that is proportional to the irradiance.
- a water-cooled metal body. This body acts as a heat sink.



Figure 2.1 SBG01 showing its metal body, black coating and cable.

SBG series users typically assume that the measured heat flux is representative of the undisturbed irradiance at the location of the sensor. Users may also apply corrections based on scientific judgement.

Using SBG series is easy. For readout, the user only needs an accurate voltmeter that works in the millivolt range. To convert the measured voltage, U , to a heat flux Φ , the voltage must be divided by the sensitivity S , a constant supplied with each individual sensor.

2.1 Detailed measurement equation

In more detail, the measurement equation of SBG series is

$$\Phi = U/S + \sigma \cdot (T + 273.15)^4 \quad (\text{Formula 2.1.1})$$

In which the first term represents the incoming irradiance, and the second term represents the irradiance emitted by the sensor. The constant σ is the Stefan-Boltzmann constant $5.67 \times 10^{-8} \text{ W}/(\text{m}^2 \cdot \text{K}^4)$.

In case the sensor temperature is of the order of 10°C , the second term is of the order of $0.45 \times 10^3 \text{ W}/\text{m}^2$, which is usually considered negligible, so that the measurement equation 2.1.1 is abbreviated to:

$$\Phi = U/S \quad (\text{Formula 0.1})$$

Measuring with heat flux sensors, errors may be caused by differences between calibration reference conditions and the conditions during use. The user should analyze his own experiment and make his own uncertainty evaluation. Comments on the most common error sources can be found in the chapter about uncertainty evaluation.

3 Specifications of SBG series

SBG series measures the heat flux density through the surface of the sensor. This quantity, expressed in W/m^2 , is called heat flux. SBG series are rated for use in environments in which the heat flux is dominated by radiation at heat flux levels $> 5 \times 10^3 W/m^2$. Working completely passive, using a thermopile sensor, SBG series thermopile generates a small output voltage proportional to this flux. Using an open detector, SBG series are also sensitive to convective heat flux. This contribution is usually ignored.

The sensor must be used at a heat flux level as close as possible to its rated measurement range which is equal to its calibration reference condition. It must be water-cooled or exposed only for a limited time interval. SBG series can only be used in combination with a suitable measurement system. In testing, the sensor must be calibrated and used in accordance with the recommended practices of ISO and ASTM. Model SBG04 is a model specifically intended for use in cone calorimeters. Its specifications, when different, are listed in a separate table.

Table 3.1 Specifications of SBG series (continued on next pages).

SBG series specifications	
sensor type	water-cooled heat flux sensor
sensor type according to ISO 14934	total heat flux sensor
measurand	heat flux
measurand in SI units	irradiance in W/m^2
heat flux sensor	thermopile
sensor technology	both Gardon and Schmidt-Boelter
sensing area diameter	$10 \times 10^{-3} m$
rated measurement ranges SBG01, SBG03	$(5, 10, 20, 50, 100 \text{ and } 200) \times 10^3 W/m^2$
limiting measurement range	150 % of rated measurement range
output signal	DC voltage
sensitivity range	depending on rated measurement range: $0.1 \text{ to } 0.7 \times 10^{-6} V/(W/m^2)$
output voltage signal range	$> 5 \times 10^{-3} V$ at rated measurement range

measurement function/required programming	$\Phi = U/S$
optional measurement function/required programming for correction of sensitivity as a function of instrument body temperature	$\Phi = U/S + \sigma \cdot (T + 273.15)^4$
required readout	1 x differential voltage channel or 1 single-ended voltage channel, input resistance $> 10^6 \Omega$
rated operating temperature range SBG01, SBG03	-30 to +80 °C (sensor body and cable gland temperature) -60 to +200 °C (cable temperature)
rated operating pressure range	sea level ambient air pressure, not suitable for use in vacuum
temperature dependence	$< 0.1\%/^{\circ}\text{C}$
non-linearity SBG01, SBG03	$< 2\%$ of rated measurement range
black coating emissivity	> 0.90
spectral range	0 to $50 \times 10^{-6} \text{ m}$
full field of view angle	180 °
response times SBG01, SBG03 (63 %) at different rated measurement ranges 5, $10 \times 10^3 \text{ W/m}^2$ 20, $50 \times 10^3 \text{ W/m}^2$ 100, $200 \times 10^3 \text{ W/m}^2$	$< 450 \times 10^{-3} \text{ s}$ $< 250 \times 10^{-3} \text{ s}$ $< 200 \times 10^{-3} \text{ s}$
sensor resistance	25 Ω (nominal)
required sensor power	zero (passive sensor)
rated operating relative humidity range	0 to 100 % (non-condensing)
standard cable length SBG01, SBG03	2 m (see options)
cable material type SBG01, SBG03	PTFE
cable diameter type SBG01, SBG03	$3 \times 10^{-3} \text{ m}$
IP protection class	IP10

sensor marking	serial number engraved on sensor body
----------------	---------------------------------------

gross weight including 2 m cable and protection cap	approx. 0.3 kg
---	----------------

net weight including 2 m cable and protection cap	approx. 0.2 kg
---	----------------

Water-cooling

typical cooling method	tap water at 3 bar supplied through and drained through a silicone hose
------------------------	---

alternative cooling method	actively cooling water circulator with water pump instead of tap water
----------------------------	--

rated exposure time interval	indefinite when water-cooled
------------------------------	------------------------------

rated cooling water operating pressure range	0 to 3 bar
--	------------

rated cooling water flow	> 10 l/hr (0.003 l/s), preferably 30 l/h (0.01 l/s)
--------------------------	---

rated cooling water temperature range	10 to 30 °C
---------------------------------------	-------------

use without water cooling SBG01, SBG03	SBG01 and SBG03 may be used uncooled at low heat flux levels or for short time intervals. See the chapter on uncooled sensors in this manual for directions.
--	--

weight of metal sensor body SBG01, SBG03	0.11 kg
--	---------

metal heat capacity	400 J/(kg·K)
---------------------	--------------

heat capacity of sensor body SBG01, SBG03	44 J/K
---	--------

outer diameter of metal cooling tubes SBG01, SBG03	4.2 x 10 ⁻³ m (3.2 x 10 ⁻³ m for SBG03 option -P150)
--	---

recommended hose for cooling water supply	6 x 10 ⁻³ m outer diameter / 3 x 10 ⁻³ m inner diameter silicone hose
---	--

recommended coupling for hose	type MCD1702 BODY 1/8 inch NPT + MCD4202 INSERT, see the catalogue via www.cpcworldwide.com
-------------------------------	---

bending of metal cooling water tubes SGB03	cooling water supply tubes are suitable for careful one-time bending at radius of > 25 x 10 ⁻³ m
--	---

Table 3.2 Use of SBG series according to test standards.

Use in testing	
standards governing use of the instrument	<p>ISO 14934-1: Reaction-to-Fire Tests - use of heat flux meters general principles</p> <p>ISO 14934-4: Reaction-to-Fire Tests - guidance on use of heat flux meters</p>
suitable for use in test	<p>ISO 5657: Reaction to fire tests - Ignitability of building products using a radiant heat source</p> <p>ISO 5658: Reaction to fire tests - Spread of flame</p> <p>ISO 5660: Reaction to fire tests - Heat release, smoke production and mass loss rate</p> <p>ISO 17554 Reaction to fire tests - Mass loss measurement</p> <p>ISO 9705:1993 Fire tests - Full-scale room test for surface products</p> <p>ISO 17431:2006 Fire tests - Reduced-scale model box test</p> <p>ISO 13785: Reaction to fire test for façades - part 1 and 3</p> <p>ISO 3008: Fire resistance tests - door and shutter assemblies</p> <p>ISO 5659: Plastics - Smoke generation - part 2: Determination of optical density by a single-chamber test</p> <p>ISO 14696: Reaction-to-fire tests - Determination of fire and thermal parameters of materials, products and assemblies using an intermediate-scale calorimeter (ICAL)</p> <p>ISO 13785: Reaction-to-fire tests for façades- part 1 intermediate scale and part 2 large scale</p> <p>ISO 9239: Reaction to fire tests for floorings — part 1: Determination of the burning behavior using a radiant heat source</p> <p>FAA FAR PART 25 APPENDIX F PART 3: Test Method to Determine Flame Penetration Resistance of Cargo Compartment Liners</p>
not suitable for use in test	<p>ASTM E 285: oxyacetylene ablation testing (heat flux is in the order of $800 \times 10^3 \text{ W/m}^2$ which is beyond the rated measurement range)</p>

Table 3.3 Installation and use of SBG series.

Installation and use	
installation	See recommendations in this manual.
cable extension	See chapter on cable extension or order sensors with longer cable.
recoating	ISO 14934-4 paragraph 9.1 allows repainting of sensors, according to manufacturer recommendations. After repainting, the sensors must be re-calibrated.
Calibration	
calibration traceability	to ITS-90
standard governing calibration	ISO 14934-3: Reaction-to-Fire Tests - calibration of heat flux meters secondary calibration
product certificate	included (showing calibration result and traceability)
calibration method	SBGC secondary calibration method according to ISO 14934-3. The Hukx SBGC method follows the recommended practice of ISO 14934-3, however we calibrate at one heat flux level only. Calibration relies on a comparison to a secondary standard heat flux sensor under a radiant heat source as described in chapter 4. The calibration reference has been characterized in the range of 0 to $75 \times 10^3 \text{ W/m}^2$. Calibration at higher heat flux levels is done at $100 \times 10^3 \text{ W/m}^2$, using linear extrapolation of the sensitivity of the calibration reference.
calibration laboratory accreditation	not accredited
calibration laboratory management system certification	ISO 9001
calibration hierarchy	from SI through international standards and through an internal mathematical procedure
calibration uncertainty	$\pm 6.5 \%$ ($k = 2$)
recommended recalibration interval of working standards	Fire tests may specify the interval of calibration of the working standard heat flux sensor. We recommend to calibrate before and after every test.

recommended maintenance of calibration reference standards

We recommend that accredited test laboratories follow the procedures described in ISO 14934-3 Annex D. They must have 3 calibration reference sensors (secondary standards, calibrated externally against a primary standard according to ISO 14934-2), used to calibrate the working standards. One of these should be designated as "principal". Clause D.14 recommends that every year one of the 3 instruments is recalibrated against the (external) primary standard. Calibration against a primary standard may be done at RISE (Sweden), NIST (USA) or LNE (France).

calibration reference conditions

cooling water temperature < 25 °C

calibration reference conditions
SBG01, SBG03

5
10
20
50
100
200

heat flux level

$5 \times 10^3 \text{ W/m}^2 \pm 5 \%$
 $10 \times 10^3 \text{ W/m}^2 \pm 5 \%$
 $20 \times 10^3 \text{ W/m}^2 \pm 5 \%$
 $50 \times 10^3 \text{ W/m}^2 \pm 5 \%$
 $100 \times 10^3 \text{ W/m}^2 \pm 5 \%$
 $200 \times 10^3 \text{ W/m}^2 \pm 5 \%$

validity of calibration

Based on experience, the instrument sensitivity will not change during storage

Measurement accuracy

uncertainty of the measurement

Statements about the overall measurement uncertainty can only be made on an individual basis. See the chapter on uncertainty evaluation.

standard governing uncertainty evaluation in tests

ISO 29473 Fire test - Uncertainty of measurements in fire tests

Versions/options

version SBG01, SBG03 rated measurement range

5, 10, 20, 50, 100, 200 x 10³ W/m²

version SBG01, SBG03 longer cable

02, 05, 10, 20, or specify length in m

version SBG03 longer water cooling tubes

-P150

order code SBG01, SBG03 version

SBG0X-rated measurement range-cable length

Accessories

spare parts

removable protection cap SBG01

accessory

handheld read-out unit LI19
programmed LI19 handheld read-out unit/data logger, two spare batteries, one USB cable, software and a transport case

Model SBG04 is a model specifically intended for use in cone calorimeters.
Its specifications, when different, are listed in this table.

Table 3.4 Specifications specifically of model SBG04 (continued next pages).

SBG04 specifications	
standardization	All specifications and dimensions standardized for use in cone calorimeters according to ISO 5660 and ASTM E1354.
operational measurement range	$(10 \text{ to } 70) \times 10^3 \text{ W/m}^2$ (covering use in cone calorimeters)
rated measurement range	$100 \times 10^3 \text{ W/m}^2$
limiting measurement range	$150 \times 10^3 \text{ W/m}^2$
rated operating temperature range	-30 to +80 °C (sensor body) -30 to +600 °C (sensor wire tube) -60 to +200 °C (cable temperature, up to +600 °C after bake out)
non-linearity	< 2 % within operational measurement range
response time (63 %)	$< 250 \times 10^{-3} \text{ s}$
output signal	$> 12 \times 10^{-3} \text{ V}$ at rated measurement range
cable material	glass fiber with silicone resin
cable diameter	$2.9 \times 10^{-3} \text{ m}$
gross weight including 2 m cable and protection cap	approx. 0.2 kg
net weight including 2 m cable and protection cap	approx. 0.1 kg

Water cooling

use without water cooling	SBG04 may not be used uncooled
weight of metal sensor body SBG04	0.023 kg
heat capacity of sensor body	8.6 J/K
outer diameter of metal cooling tubes	3.2×10^{-3} m (1/8 inch)
recommended fittings for metal cooling tubes	type B-200-9 tube fitting 1/8 inch outer diameter, see the catalogue via www.swagelok.com
bending of metal cooling water tubes SBG04	Cooling water supply tubes are suitable for careful one-time bending after "tube support ring" at radius of $> 25 \times 10^{-3}$ m.

Use in testing

suitable for use in test	ISO 5660: Reaction to fire tests - Heat release, smoke production and mass loss rate
--------------------------	--

Installation and use

installation	see recommendations in this manual and the ISO 5660 or ASTM E1354 norms
--------------	---

Calibration

calibration reference conditions SBG04 100	heat flux level 50×10^3 W/m ² ± 5 %
---	--

Versions/options

version SBG04 rated measurement range	100×10^3 W/m ²
version SBG04 standard cable length	2 m
order code SBG04 version	SBG04-100-02

3.2 Dimensions of SGB01

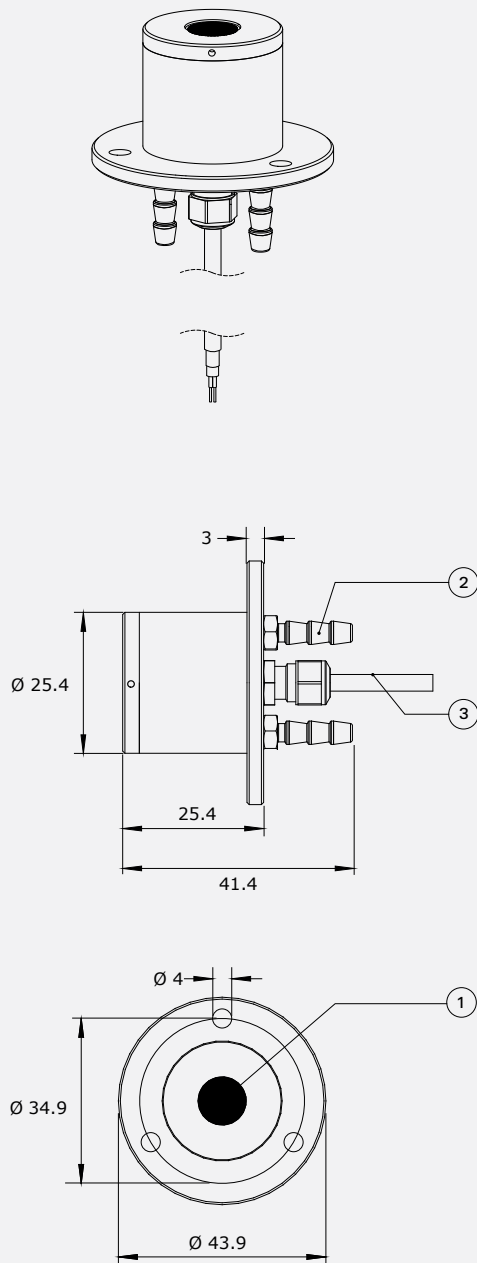

Figure 3.2.1 SGB01 heat flux sensor with a smooth body and flange, dimensions in $\times 10^{-3}$ m. From top to bottom: 3D view, side view, front view

1. thermopile sensor with black coating, diameter sensing area: 10×10^{-3} m
2. water cooling tube, outer diameter tubes: 4.2×10^{-3} m
3. PTFE cable, standard cable length is 2 m

3.3 Dimensions of SGB03

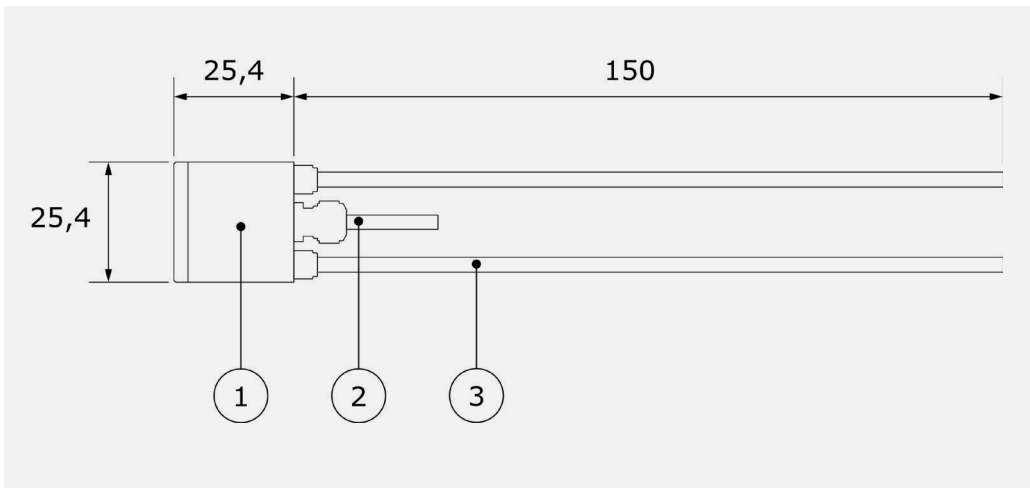

Figure 3.3.1 SGB03-010-02-P150 heat flux sensor with a smooth body, side view dimensions in $\times 10^{-3}$ m.

1. thermopile sensor with black coating, diameter sensing area: 10×10^{-3} m
2. PTFE cable, standard cable length is 2 m
3. option -P150 water cooling tube, outer diameter tubes: 3.2×10^{-3} m (1/8")

3.4 Dimensions of SGB04

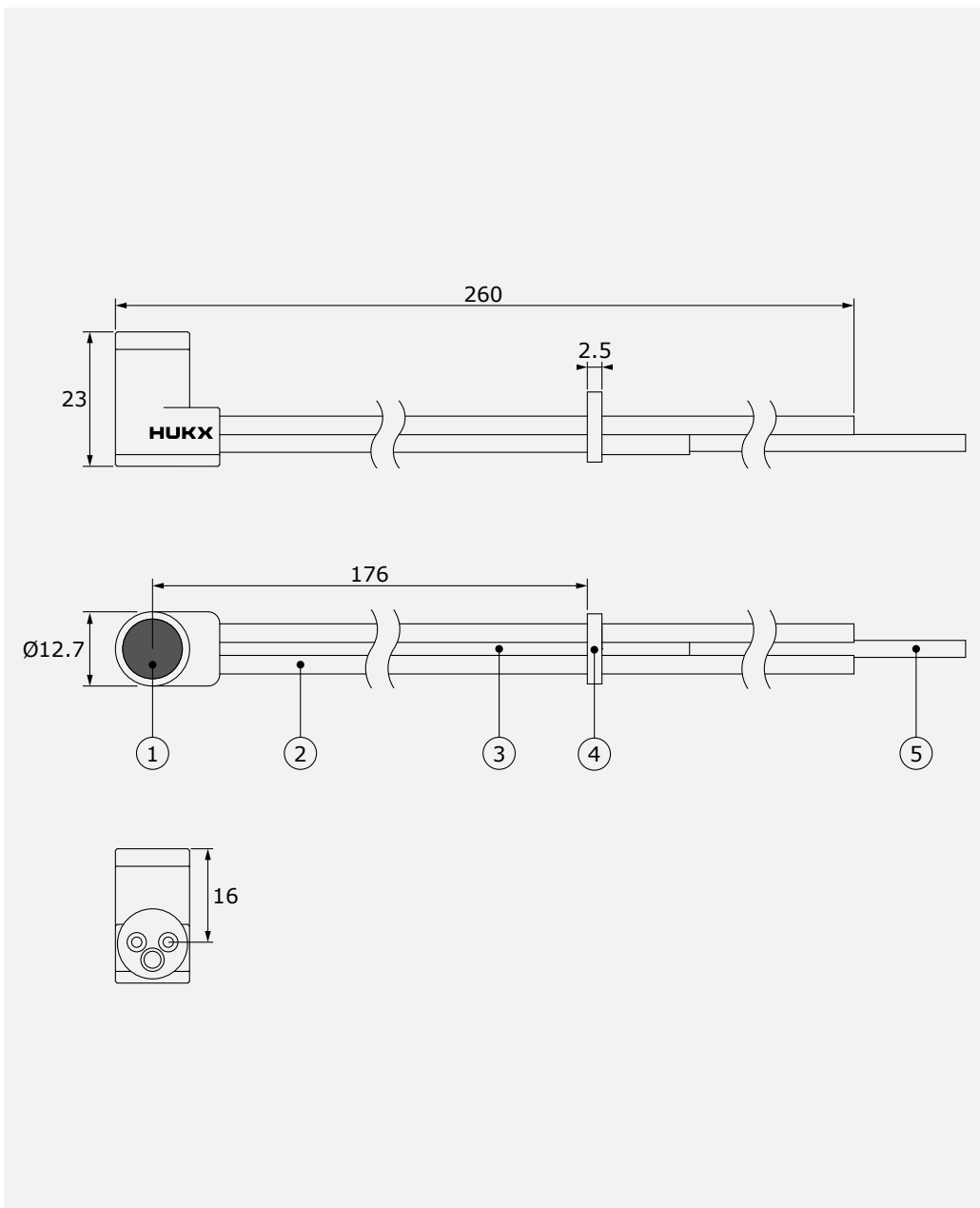

Figure 3.4.1 SGB04 heat flux sensor, dimensions in $\times 10^{-3}$ m. From top to bottom: front view, top view, side view

1. thermopile sensor with black coating, diameter sensing area: 10×10^{-3} m
2. water cooling tube, outer diameter tubes: 3.2×10^{-3} m (1/8")
3. sensor wire tube
4. tube support ring, positioning stop for cone calorimeter
5. cable, standard cable length is 2 m

4 Standards and recommended practices for use

Calibration and use of heat flux sensors (officially "heat flux meters") such as SBG series is subject to standardized practices according to ISO 14934 "Reaction-to-Fire tests - calibration of heat flux meters". The same procedures will be adopted by ASTM. As cone calorimeter reference sensor, SBG04 is also subject to ISO 5660 "Reaction-to-fire tests - Heat release, smoke production and mass loss rate". In case the user performs accredited testing or works in an accredited organization, the user must comply with these standards.

NOTICE

When following standard operating practices, users should purchase their own copies of the standard. This manual offers general guidelines for use only.

4.1 Heat flux measurement in fire testing: ISO 14934

The ISO 14934 standard has 4 parts. We recommend users to purchase the latest version of the standard.

Table 4.1.1 Standards with recommendations for instrument use in fire testing.

Standards for heat flux sensor use in fire testing

ISO standard	equivalent ASTM standard
ISO 14934 "Reaction-to-Fire tests—calibration of heat flux meters" part 1: general principle part 2: primary calibration methods part 3: secondary calibration methods part 4: guidance on use of heat flux meters	No equivalent ASTM standard

The most important requirements of the standard are:

- To have 3 local "secondary standard" calibration reference standards (i.e. sensors calibrated against a primary standard according to ISO14934-2) for calibration of the "working standards" (i.e. the instruments used for day-to-day work for calibration of test equipment). Calibration according to ISO 14934-2 may be done at NIST (USA), RISE (Sweden) or LNE (France). Of the 3 calibration reference instruments, 2 instruments must be kept unused until unexpected results appear or until the first calibration reference standard is sent away for recalibration. A typical expanded uncertainty of the sensitivity at SP is in the order of 2 to 3 % ($k = 2$) in a range from 5 to 75 x 10³ W/m².

- To calibrate every 2 years one of the reference standards against a primary standard. After calibration, this instrument is used to verify the uncertainty of the other 2 calibration reference standards. A single reference standard is usually calibrated at multiple heat flux levels. It can be used as a reference in the same heat flux range, and by extrapolation also at higher levels.
- To use working standards only at an irradiance level close to its calibration reference condition.
- To compare working standards to a local reference standard before every test and preferably after every test, following the method specified in ISO 14934-3. The comparison requires a local irradiance source, for example a cone calorimeter.

4.2 SBG04 in cone calorimeter testing: ISO 5660 and ASTM E1354

The ISO 5660 standard has 4 parts. We recommend users to purchase the latest version of the standard.

Table 4.2.1 Standards with recommendations for instrument use in cone calorimeter.

Standards for heat flux sensor use in cone calorimeter	
ISO standard	equivalent ASTM standard
ISO 5660 "Reaction-to-fire tests—Heat release, smoke production and mass loss rate" part 1: Heat release rate (cone calorimeter method) part 3: Guidance on measurement part 4: Measurement of heat release for determination of low levels of combustibility part 5: Heat release rate (cone calorimeter method) and smoke production rate (dynamic measurement) under reduced oxygen atmospheres	ASTM E1354

The most important requirements of the standard are:

- The flux meter shall be positioned at a location equivalent to the center of the specimen face during calibration.
- The receiving target shall be flat, circular, of approximately 12.5 mm (half inch) in diameter with a durable matt black finish.
- At maximum intervals of 100 working hours, check the operating heat flux meter against the reference heat flux meter.
- The calibration of the working heat flux meter shall be checked by comparison with two instruments of the same type and of similar range held as reference standards and not used for any other purpose. One of the reference standards shall be fully calibrated at a standardizing laboratory at yearly intervals.
- The flux meter shall always be used with water-cooling.

5 Installation of SGB series

5.1 Installation in fire testing

Table 5.1.1 Recommendations for installation of heat flux sensors in fire testing.

standard operating practices	If the test is carried out in accordance with a standard: look for recommendations in the standard.
orientation	The sensor will work in any orientation.
protection cap	Use the cap during transport and storage. Remove the cap when installing and during measurements.
water-cooling	Usually tap water is used, supplied and led out through silicone hoses. See the chapter on cooling.
electrical connection	The sensor generates a small voltage output signal. No power supply is required. Connect the 2 conductors to a data acquisition system. See the chapter on electrical connection.
signal amplification	See the paragraph on electrical connection.
mechanical mounting SBG01	Use the 3 holes in the flange for sensor mounting. Make sure that the object that is used for mounting the flange remains relatively cool. Heat should not conduct easily through the flange to the sensor body.
mechanical mounting SBG03, SBG04	Use a circular clamp or equivalent to mount the sensor. Make sure that the object that is used for mounting remains relatively cool. Heat should not conduct easily to the sensor body.
cable mounting	Provide the cable with an additional strain relief.
added temperature sensors	To verify the functionality of the water-cooling, you may connect a temperature sensor to the heat flux sensor body.
heat shielding	Shield the body sensor and cable as much as possible from radiated and convective heat.

5.2 Installation in cone calorimeter

Table 5.2.1 Recommendations for installation of SBG04 in cone calorimeter.

standard operating practices	If the test is carried out in accordance with the ISO 5660 or ASTM E1354 standard: look for recommendations in the standard.
orientation	The sensor will work in any orientation. Face the sensitive area towards the cone heater, positioned at a location equivalent to the center of the specimen face during calibration.
protection cap	Use the cap during transport and storage. Remove the cap when installing and during measurements.
water-cooling	Water-cooling should always be applied. Usually tap water is used, supplied and led out through 1/8" tube fittings with silicone hoses. See the chapter on cooling.
electrical connection	The sensor generates a small voltage output signal. No power supply is required. Connect the 2 conductors to the cone calorimeter data acquisition system. See the chapter on electrical connection.
signal amplification	See the paragraph on electrical connection.
mechanical mounting SBG04	A "Flux meter mount" is usually supplied with the cone calorimeter equipment and clamped onto the water cooling tubes. For recommended dimensions of the slot in the "Flux meter mount" see Figure 5.5.3
cable mounting	Provide the cable with an additional strain relief.
heat shielding	Keep the cable away from direct exposure of the cone heater.

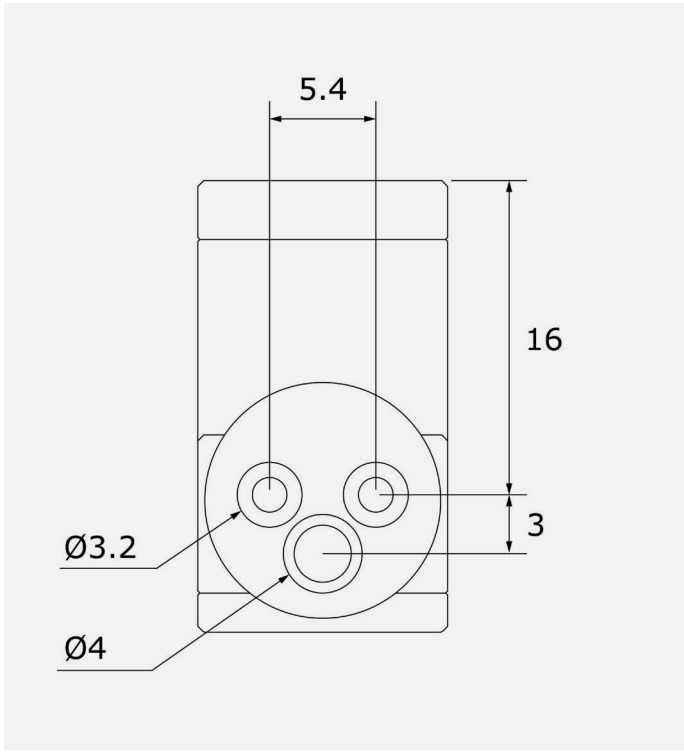

Figure 5.2.2 Dimensions for cone calorimeter mounting, sensitive area to cooling tubes center 16 mm.

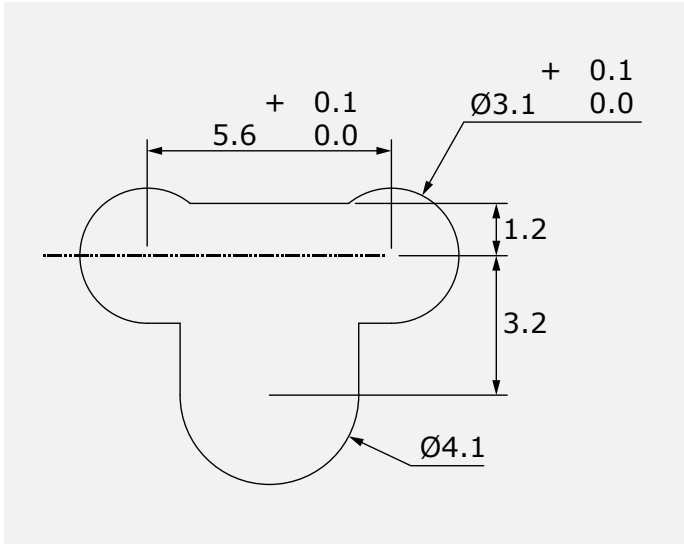

Figure 5.2.3 Suggested slot dimensions for SBG04 cone calorimeter "Flux meter mount".

5.3 Electrical connection

A heat flux sensor should be connected to a measurement system, typically a so-called data logger. SBG series are passive sensors that do not require power. Cables may act as a source of distortion, by picking up capacitive noise. We recommend keeping the distance between a data logger or amplifier and the sensor as short as possible. For cable extension, see the appendix on this subject.

Table 5.3.1 The electrical connection of SBG series.

wire		measurement system
white	signal [+]	voltage input [+]
black	signal [-]	voltage input [-] or ground
blank	shield	ground

NOTICE

Putting more than 12 Volt across the sensor wiring can lead to permanent damage to the sensor.

5.4 Requirements for data acquisition/amplification

The selection and programming of data loggers is the responsibility of the user. Please contact the supplier of the data acquisition and amplification equipment to see if directions for use with SBG are available. In case a program for similar instruments is available, this can be used. All SBG's can be treated in the same way as other heat flux sensors and (analogue) thermopile pyranometers.

NOTICE

Do not use "open circuit detection" when measuring the sensor output.

Table 5.4.1 Requirements for data acquisition and amplification equipment for SBG series in the standard configuration.

capability to measure small voltage signals	preferably: $< 5 \times 10^{-6} \text{ V}$ uncertainty minimum requirement: $20 \times 10^{-6} \text{ V}$ uncertainty (valid for the entire expected temperature range of the acquisition/amplification equipment)
capability for the data logger or the software	To store data, and to perform division by the sensitivity to calculate the heat flux. $\Phi = U/S$ (Formula 0.1)
data acquisition input resistance	$> 1 \times 10^6 \Omega$
open circuit detection (NOTICE)	Open-circuit detection should not be used, unless this is done separately from the normal measurement by more than 5 times the sensor response time and with a small current only. Thermopile sensors are sensitive to the current that is used during open circuit detection. The current will generate heat, which is measured and will appear as a temporary offset.

5.5 Cooling

For normal applications in fire research, the standard 3 bar pressure of tap water supply are sufficient for operating heat flux meters. In case of extremely high fluxes, which are not relevant to SBG series (above $2500 \times 10^3 \text{ W/m}^2$), additional pressure may be necessary. As water has a very high heat capacity, for 1 inch ($25.4 \times 10^{-3} \text{ m}$) diameter sensors a water supply of 30 l/hr or 0.01 l/s is sufficient to carry away all the generated heat with a temperature rise of less than $10 \text{ }^\circ\text{C}$, taking a safety factor of 4. An alternative possibility is to use a large vessel filled with water or coolers such as supplied by the Julabo company, such as model F250 recirculating cooler. The Julabo equipment is a closed-circuit water cooler with a convective heat exchanger.



Figure 5.5.1 Example of an active water cooler with a pump: Julabo F250.

5.6 Non-cooled sensors

SBG01 and SBG03 may be used non-cooled (so not connected to the water supply).
SBG04 may not be used non-cooled. This can be considered if:

1. The exposure is so short that SBG does not significantly heat-up; typically this requirement is fulfilled in case the time is less than 1 second.
2. The flux is so low that SBG cannot significantly heat-up; typically this requirement is fulfilled in case fluxes are $< 1 \times 10^3 \text{ W/m}^2$. In this case, it is relevant to consider that the measurement will be inaccurate because of the non-linearity and emission of radiation by the sensor itself.
3. There is a large additional heat sink (for instance a block of metal or melting stearin) attached to SBG.

In all cases we recommend:

4. To verify that temperature of the sensor body remains below 80 °C. The limit of materials is 150 °C, but the center of the sensor gets hotter than the body.
5. To minimize the exposed surface area by adding heat shields and insulation.
6. To calculate temperature rise before experimenting; the SBG01 weight is around 0.11 kg, so it has a heat capacity of 44 J/K (heat capacity of metal is around 400 J/(kg·K)).
7. Add as much thermal mass as possible.

Example calculation: at a heat flux of $100 \times 10^3 \text{ W/m}^2$ and having an exposed surface area of 0.0005 m^2 , the incoming energy is 50 W, which results in 1.2 K/s temperature rise. Starting at 20 °C sensor body temperature, without cooling a measurement time interval of 50 s is feasible. The sensor body will then reach 80 °C.

NOTICE

Using SBG04 without water cooling may lead to permanent damage to the sensor.

Using SBG01 and SBG03 without water cooling may lead to permanent damage to the sensor when the sensor body temperature exceeds 80 °C.

6

Making a dependable measurement

6.1 Uncertainty evaluation

The measurement uncertainty is a function of:

- calibration uncertainty
- differences between reference conditions during calibration and measurement conditions, for example uncertainty caused by non-linearity
- damage during sensor employment
- application errors: the measurement conditions and environment in relation to the sensor properties, the influence of the sensor on the measurand, the representativeness of the measurement location
- convective heat transport

It is not possible to give one figure for heat flux sensor measurement uncertainty. Statements about the overall measurement uncertainty can only be made on an individual basis, taking all these factors into account.

Guidelines for uncertainty evaluation:

1. The formal evaluation of uncertainty should be performed in accordance with ISO 98-3 Guide to the Expression of Uncertainty in Measurement, GUM.
2. Uncertainties are entered in measurement equation (equation is usually Formula 0.1: $\Phi = U/S$), either as an uncertainty in E (non-representativeness, resistance error and deflection error) in U (voltage readout errors) or in S (non-stability, temperature dependence, calibration uncertainty).
3. In case of special measurement conditions, typical specification values are chosen. These should for instance account for environmental conditions (working temperature range).
4. Among the various sources of uncertainty, some are "correlated"; i.e. present during the entire measurement process, and not cancelling or converging to zero when averaged over time; the off-diagonal elements of the covariance matrix are not zero. Paragraph 5.2 of GUM.
5. Among the various sources of uncertainty, some are "uncorrelated"; cancelling or converging to zero when averaged over time; the off-diagonal elements of the covariance matrix are zero. Paragraph 5.1 of GUM.

6.2 Contributions to the uncertainty budget

6.2.1 Calibration uncertainty at Hukx

SBG series factory calibration uncertainty under reference conditions is $\pm 6.5\%$ with a coverage factor $k = 2$.

As a user of SBG series, you may attain a similar uncertainty when calibrating against your local calibration reference standard.

6.2.2 Uncertainty caused by non-linearity

The SBG01 and SBG03 are calibrated at its rated measurement range, however with a minimum of $5 \times 10^3 \text{ W/m}^2$ and a maximum at $100 \times 10^3 \text{ W/m}^2$, the SBG04 is calibrated at $50 \times 10^3 \text{ W/m}^2$. When measuring at a fraction of the rated measurement range, the sensor output ideally varies linearly with the heat flux.

The deviation from this ideal behavior is captured in the so-called non-linearity.

The non-linearity is expressed as a percentage of the rated measurement range. Non-linearity related uncertainty can be quite large, which is why we recommend to employ sensors measuring close to their rated measurement range.

The non-linearity specification is $\pm 2\%$ of the rated measurement range.

For the model SBG01-200 with a rated measurement range of $200 \times 10^3 \text{ W/m}^2$, the $\pm 2\%$ contributes $4 \times 10^3 \text{ W/m}^2$ to the uncertainty budget. When measuring with the same sensor at $20 \times 10^3 \text{ W/m}^2$, this is an uncertainty contribution of $\pm 20\%$, which is quite large compared to the calibration uncertainty of 6.5% .

A model SBG01-20 has an uncertainty contribution of only $0.4 \times 10^3 \text{ W/m}^2$ or $\pm 2\%$ due to non-linearity at the same heat flux level of $20 \times 10^3 \text{ W/m}^2$.

For the SBG04-100 the non-linearity specification is valid over the operational measurement range of $(10 \text{ to } 70) \times 10^3 \text{ W/m}^2$, covering use in cone calorimeters.

6.2.3 Uncertainty caused by convection

The SBG series are not shielded. Convective heat transport, typically by hot gasses, may act as a source of measurement error. To estimate the associated uncertainty, the user may design experiments to vary local heat transfer.

7 Maintenance and trouble shooting

7.1 Recommended maintenance and quality assurance

SBG series are typically located in hostile environments in which the sensor is under constant threat of being damaged. Unreliable measurement results are detected by very frequent recalibration, by visual inspection of the sensor and by scientific judgement, for example by looking for unreasonably large or small measured values. Preferably the measurement is done by multiple sensors, which makes it possible to check against other measurements.

Table 7.1.1 Recommended maintenance of SBG series.

Minimum recommended heat flux sensor maintenance			
	interval	subject	action
1	before and after every test	recalibration	Recalibrate against a local calibration reference.
2	before and after every test	inspection	Inspect sensor coating, cable quality, inspect mounting, inspect the water supply tubing.
3	after every test	data review	Judge the feasibility of the measurement data compare to measurements with other sensors, typically heat flux and temperature measurements.
4	after every test	lifetime assessment	Judge if the instrument will be reliable for another test.

7.2 Trouble shooting

Table 7.2.1 Trouble shooting for SBG series (continued on the next page).

general	<p>Inspect the sensor for any damage.</p> <p>Inspect if the wires are properly attached to the data logger.</p> <p>Check the condition of the cable.</p> <p>Check the data logger program in particular if the right sensitivity is entered.</p> <p>Check the electrical resistance of the sensor between the black [-] and white [+] wires. Use a multimeter at the 100 Ω range. Measure the sensor resistance first with one polarity, then reverse the polarity. Take the average value. The typical resistance of the wiring is 0.1 Ω/m. Typical resistance should be the nominal sensor resistance of 25 Ω for plus 1.5 Ω for the total resistance of two wires (back and forth) of each 2 m. Infinite resistance indicates a broken circuit; zero or a lower than 1 Ω resistance indicates a short circuit.</p>
The sensor does not give any signal	<p>Remove the white cap from the sensor. Check if the sensor reacts to heat: put the multimeter at its most sensitive range of DC voltage measurement, typically the 100 x 10⁻³ VDC range or lower. Expose the sensor heat, for instance, by putting a flame from a consumer type gas lighter at a distance of around 0.01 m. The signal should read > 2 x 10⁻³ V now. Do not expose for more than 10 s. Check the data acquisition by replacing the sensor with a spare unit.</p>
The sensor signal is unrealistically high or low	<p>Check the cable condition looking for cable breaks.</p> <p>Check the data acquisition by applying a 1 x 10⁻⁶ V source to it in the 1 x 10⁻⁶ V range. Look at the measurement result. Check if it is as expected.</p> <p>Check the data acquisition by short circuiting the data acquisition input with a 10 Ω resistor. Look at the output. Check if the output is close to 0 W/m².</p>
The sensor signal shows unexpected variations	<p>Check the presence of strong sources of electromagnetic radiation (radar, radio).</p> <p>Check the condition and connection of the shield.</p> <p>Check the condition of the sensor cable.</p> <p>Check if the cable is not moving during the measurement.</p>

7.3 Recoating/repainting of sensor surfaces

ISO 14934-4 paragraph 9.1 allows repainting of sensors, according to manufacturer recommendations.

Hukx recommendations are:

Repainting is preferably done by the manufacturer.

Do-it-yourself repainting is possible, but if that is done all product warranties are cancelled.

Judge by visual inspection if the thermopile sensor is still well attached to the metal sensor body. If not, the sensor is beyond repair. Verify sensor functionality. This can also be done with a non-coated sensor (see the chapter of the quick sensor test). The thermopile is then visible through its orange-colored plastic cover.

Purchase a matt (not glossy) black paint which is temperature resistant up to 600 °C. Silicone-based black paints are a good choice. Typically, aerosol spray cans are most easy to use, but such paints can also be used purchased in cans. In case a solvent is needed: typically, acetone is a good solvent for these paints.

Surface preparation: In case the existing sensor surface coating has small scratches, but is otherwise in good condition, do not clean, but apply new paint directly to the existing paint. In case of heavy damage to sensor surface coatings: remove the existing coating, clean with acetone or ethanol. Lightly sand the orange plastic surface. Take care to leave the thermopile plastic cover intact.

Paint application: the sensor surface is located in a 0.1×10^{-3} m deep locally lower surface in the SBG series body. Spray some paint in a small cup, use a pipette to apply the paint. In case a pipette is not available, use a small paint brush.

Curing: most coatings require curing to reach the required temperature specification. Cure the coating according to the manufacturer's recommendation. Be careful not to expose the sensor to temperatures above 150 °C.

Recalibration: newly coated sensors should be recalibrated.

We do not expect significant (> 5 %) changes relative to the original sensitivity.

7.3.1 Hukx factory coating process

Hukx uses RUST-OLEUM® Hard Hat 7778 Bar-B-Q-Black.

After application, the coating is allowed to dry for at least 3 hours at room temperature and then heated to 150 °C in stages of max. 50 °C/hour. Ideally, an oven with a ramp function is used. Allow to cool for 24 hrs, the coating is now fully cured.

8 Appendices

8.1 Appendix on cable extension / replacement

SBG series are equipped with one cable. Keep the distance between data logger or amplifier and sensor as short as possible. Cables may act as a source of distortion by picking up capacitive noise. In an electrically "quiet" environment the SBG series cable may be extended without problem to 100 meters. If done properly, the sensor signal, although small, will not significantly degrade because the sensor resistance is very low (which results in good immunity to external sources) and because there is no current flowing (so no resistive losses). Cable and connection specifications are summarized below.

Table 8.1.1 Preferred specifications for cable extension of SBG01.

cable	2-wire, shielded, with copper conductor
extension sealing	Make sure any connections are sealed against humidity ingress.
conductor resistance	< 0.1 Ω /m
cable outer diameter	typically 4×10^{-3} m
length	Cables should be kept as short as possible, in any case the total cable length should be less than 100 m.
outer mantle	With the proper temperature specifications. Typically the mantle and cladding are made of PTFE.
connection	Either solder the new cable conductors and shield to those of the original sensor cable, and make a waterproof connection using heat-shrink tubing with hot-melt adhesive, or use gold plated waterproof connectors. Always connect the shield.

8.2 Appendix on calibration hierarchy

SBG series factory calibration is traceable from SI through international standards and through an internal mathematical procedure. The formal traceability of the generated heat flux is through a secondary standard calibration reference to the international temperature standard ITS90.

"The Hukx SBGC method follows the recommended practice of ISO 14934-3, however we calibrate at one heat flux level only. Calibration relies on a comparison to a secondary standard heat flux sensor under a radiant heat source as described in chapter 4. The calibration reference has been characterized in the range of 0 to $75 \times 10^3 \text{ W/m}^2$. Calibration at higher heat flux levels is done at $100 \times 10^3 \text{ W/m}^2$, using extrapolation of the sensitivity of the calibration reference.

8.3 Appendix on typical heat flux ranges

Irradiance from blackbody covering 180° full field of view angle.

Table 8.3.1 Irradiated heat flux versus equivalent blackbody source temperature calculated using Stefan Boltzmann's law.

	$\times 10^3 \text{ W/m}^2$	equivalent blackbody temperature $^\circ\text{C}$
1	0.4	10
2	20	500
3	60	750
4	150	1000
5	200	1100
6	266	1200

An indication of allowable heat flux levels for personnel and equipment can be found below.

Table 8.3.2 Allowable heat flux levels in industrial environments.

		$\times 10^3 \text{ W/m}^2$	Btu/Hr Ft²
1	equipment	9.5	3000
2	human: run	6.3	2000
3	human: walk	4.7	1500
4	human: work (static)	1.6	500

Table 8.3.3 Typical ranges of heat flux levels, from ISO 14934-4.

	x 10³ W/m²	comment
1	300	maximum level in a fully developed fire
2	200 to 100	incident heat flux on the wall in a developed fire enclosure
3	about 100	radiation from burning house
4	about 30	causing ignition of tree
5	20 to 10	causing ignition of timber
6	about 7 or 8	lowest level for causing ignition of a timber wall under a pilot flame
7	about 4	lowest level for causing a burn
8	about 2.5	highest level for people to endure
9	1.5	solar constant, maximum level of solar irradiance

Table 8.3.4 Typical ranges of heat flux levels, from ISO 5569 (continued on next page).

	x 10³ W/m²	comment
1	300	jet fire peak
2	200	jet fire average and fully developed fire > 10 x 10 ⁶ W
3	140	premixed blow torches oxyacetylene
4	120 to 145	peak floor values in post flashover room fires
5	115 to 230	peak wall values in post flashover room fires
6	105 to 175	peak ceiling values for post flashover room fires
7	90 to 200	average wall values for post flashover room fire
8	70 to 150	average ceiling values for post flashover room fire
9	50 to 150	high ventilation fully developed room fire 5 % to 10 % O ₂ by volume
10	60 to 120	premixed gas burner

11	40 to 115	on facade 0.8 m to 3.3 m above window at lintel
12	40 to 70	low ventilation fully developed fire 1 % to 5 % O ₂ by volume
13	30 to 40	small (up to 250 mm high) gas diffusion flames
14	25 to 45	flux on wall from vertical wall burning
15	25	flux below vertical spreading wall flame
16	< 25	oxidative pyrolysis fire 5 % to 21 % O ₂ by volume
17	20 to 40	developing fire with 10 % to 15 % O ₂ by volume
18	20 to 25	heat flux at floor level in flashover fire with ceiling temperature > 600 °C
19	18 to 20	match flames
20	10 to 40	output from waste paper basket fires
21	12 to 22	critical ignition flux of many materials, e.g. polyethylene, polyacetal, PMMA, wood, hardboard

8.4 Appendix on typical SBG series sensitivities

Table 8.4.1 Typical sensitivities per model, 2015 production figures, not to be used as reference.

	model SBG – [measurement range]	sensitivity x 10 ⁻⁶ V/(W/m ²)
1	SBG01-05 & 10	0.25 to 0.65
2	SBG01-20 & 50	0.28 to 0.42
3	SBG01-100 & 200	0.10 to 0.20
4	SBG04-100	0.12 to 0.23

8.5 Appendix on sensor design: Gardon versus Schmidt-Boelter

The general name for the SBG series type sensor is nowadays “total heat flux meter”: according to ISO 14934-1 paragraph 3 definition 3.17, and Annex A.2. The so-called Gardon and Schmidt-Boelter designs (named after their inventors) are also “total heat flux meters”. From a metrology point of view, there is no difference. They all measure heat flux and are traceable to the same reference. The discussion what design to use is not relevant. New standards in fire testing will probably avoid using the Gardon or Schmidt-Boelter names.

SBG series actually uses the multiple thermocouple thermopile of the Schmidt-Boelter model, and the foil technology of the Gardon model. The SBG series combines the best of both technologies and is manufactured according to both designs.

8.6 EU declaration of conformity

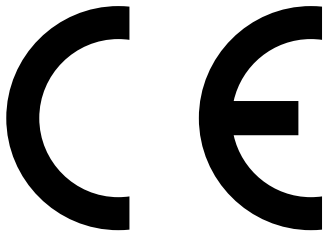

We, **Hukseflux Thermal Sensors B.V.**,
Delftechpark 31, 2628 XI, Delft,
The Netherlands

hereby declare under our sole responsibility that:

Product models	SBG series, all models
Product type	heat flux sensor
Brand name	Hukx

is in conformity with the following directives:

2011/65/EU, EU 2015/863 The Restriction of Hazardous Substances Directive

This conformity is declared using the relevant sections and requirements of the following standards:

Hazardous substances RoHS2 and 215/863 amendment known as RoHS 3

Eric HOEKSEMA
Director
Delft, 15 November 2022

About Hukx

Hukx is the leading innovator in solar radiation and heat flux sensor technology. We are proud to set the standard in high-accuracy measurement, and to be working at the heart of the energy transition.

Customers worldwide rely on our bestselling pyranometers and heat flux sensors. From sensor design and selection to supply and recalibration, we support you across the entire lifecycle.

Hukx is headquartered in the Netherlands, with locally owned representative sales offices in the USA, Brazil, India, China, Southeast Asia, and Japan.

Let us help you select the best sensor for your application. Get in touch with our experts today via: info@hukx.com

© Hukx

Version 2505

We reserve the right to change specifications without prior notice.

www.hukx.com

HUKX