

**HUKX**

Sensor  
Technology

Brochure  
Multi-purpose thermal  
needle system

**MTN02**

# MTN02

## Multi-purpose thermal needle system

for thermal conductivity/resistivity measurement

The MTN02 performs fast measurements of the thermal conductivity and resistivity of soils. Measurement with MTN02 complies with ASTM D5334 and IEEE 442 standards. The system is primarily designed for laboratory (indoor) measurements but can also be used for on-site (field) measurements. MTN02 is operated and powered from the handheld control and read-out unit CRU02.

MTN02 is a thermal needle measuring system both for laboratory and on-site measurement of the thermal conductivity of soils. The measurement method is based on the use of a "thermal needle". This method employs a heating wire and a temperature sensor in a needle. The MTN02 measuring system consists of the thermal needle, model TP07, mounted on an insertion tool, IT03, and a control and read-out unit CRU02.

MTN02 is easy to use. The needle is inserted into the soil. The user performs control and read-out of the measurement from the handheld CRU02. The measurement result is generated immediately by the CRU02 from the analysis of the time series of the temperature and the heating power during the heating interval.

Figure 1 MTN02: Mounted on insertion tool IT03, the thermal needle TP07 is inserted into the soil.



## System extension for field measurement

For on-site (field) use, the system may be extended with a sensor mounted on a long lance. See system [TNS02](#).

## Standards

Applicable standards are IEEE 442-1981(03) *Guide for Soil Thermal Resistivity Measurements* and ASTM D5334-14 *Standard Test Method for Determination of Thermal Conductivity of Soil and Soft Rock*.

## Suggested use

- laboratory analysis of soil specimens
- on-site (field) measurements close to the surface
- with extension for on-site (field) measurements (see [TNS02](#))

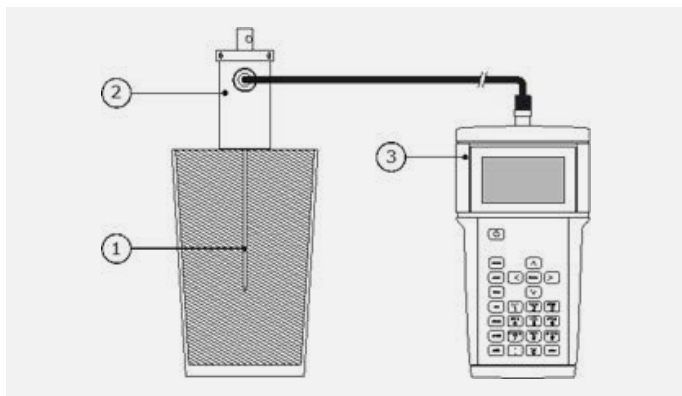

Figure 2 MTN02 system in operation: thermal needle TP07 (1), mounted on the insertion tool IT03 (2), is inserted into the soil sample. The user performs control and read-out of the experiment from the CRU02 (3), using its keyboard and LCD.

## MTN02 design and benefits

Suitable for laboratory measurements: MTN02 is primarily designed to perform laboratory measurements. The needle, model TP07, is relatively thin so that common specimens (core samples) may be used. The IT03 can be mounted on a lever that is commonly used in machine shops with which the needle can be vertically inserted into the specimen.

Suitable for (on-site) field measurements: provided that the soil is relatively soft, MTN02 may be used for field measurements. In case of harder soils or measurements at greater depths we recommend use of stronger needles and a lance (like in the system [FTN02](#)), or guiding tubes (see below). MTN02 performs measurements as a stand-alone unit.



Figure 2 GT03 guiding tubes (not included)

Suitable for hard soils and concretes: use MTN02 in combination with [GT series](#) Guiding tubes (ordered separately in sets of 5). Using these tubes it is possible to measure in hard materials such as cements and thermal backfill (heavy clay) and dried-out soil by casting them into specimens.

Easy data processing: CRU02 gives an immediate indication of the end result and an indication of the reliability of the measurement. It can store 50 measurements. ASTM and IEEE require that the end result is visually checked and recalculated. This is typically done during later analysis of the measured data in a spreadsheet. CRU02 is connected to a PC by using USB.

Local calibration/conformity assessment: The accuracy of the measuring system can be verified before a survey by measurement in glycerol. For high accuracy verification against a reference material with formal traceability, [CRC series](#) calibration reference cylinder can be purchased separately.

## Ordering

Please consult the product manual. The standard configuration of MTN02 includes one spare needle. [Product training is available upon request.](#)

## See also

Hukx is specialized in thermal needle design. Other models, for instance for laboratory use, are available at Hukx. Consult the brochures of complementary systems [FTN02](#) and [TNS02](#). Please also take a look at [TPSYS02](#), which is more accurate but has less robust needles; [GT series](#) Guiding tubes, for use in hard soils/ cement) and [CRC series](#) calibration reference cylinder. We also provide separate solutions for measurements of sediment core samples and off-shore measurement at large depths (down to 3000 m).

## MTN02 specifications

### General specifications

measurand	<ul style="list-style-type: none"><li>– thermal conductivity</li><li>– thermal resistivity</li><li>– temperature</li></ul>
measurement range	0.1 to 6 W/(m·K) (all common soils)
rated operating temperature range	from 0 to + 50 °C
measurement method	absolute measurement per ASTM D5334-14 and IEEE 442-1981 (03)
data analysis	initial analysis by CRU, final review of measurement on PC using stored data (required by ASTM)

uncertainty (at 20 °C)	± (6 % of reading + 0.04) W/(m·K)
heating interval	300 s (typical)
data storage capacity	50 measurements
length TP07	0.12 m
diameter TP07	3.5 x10 <sup>-3</sup> m
data communication	USB

## About Hukx

Hukx is the leading innovator in solar radiation and heat flux sensor technology. We are proud to set the standard in high-accuracy measurement, and to be working at the heart of the energy transition.

Customers worldwide rely on our bestselling pyranometers and heat flux sensors. From sensor design and selection to supply and recalibration, we support you across the entire lifecycle.

Hukx is headquartered in the Netherlands, with locally owned representative sales offices in the USA, Brazil, India, China, Southeast Asia, and Japan.

Let us help you select the best sensor for your application. Get in touch with our experts today via: [info@hukx.com](mailto:info@hukx.com)

© Hukx

Version 2504

We reserve the right to change specifications without prior notice.

[www.hukx.com](http://www.hukx.com)

**HUKX**