



HUKX

Sensor
Technology

User manual

Water-cooled high heat flux
sensor engineered for harsh
industrial environments

HFS01

Warning statements



Putting more than 12 Volt across the sensor wiring can lead to permanent damage to the sensor.



Do not use "open circuit detection" when measuring the sensor output.



Using sensors without water cooling may lead to permanent damage to the sensor.



Do not apply a point load on the sensor.



Twisting the metal-sheathed cable might damage it.



Hukx performs traceable calibrations and is certified according to ISO 9001, but is not an ISO 17025 accredited calibration laboratory.

Contents

Introduction	5
1 Ordering and checking at delivery	8
1.1 Ordering HFS01	8
1.2 Included items	8
1.3 Quick instrument check	9
2 Instrument principle and theory	10
2.1 Instrument principle and theory	10
2.2 Detailed measurement equation	11
3 Specifications of HFS01	13
3.1 Dimensions of HFS01	18
4 Standards and recommended practices for use	19
5 Installation of HFS01	20
5.1 Installation	20
5.2 Electrical connection	21
5.3 Requirements for data acquisition/amplification	22
5.4 Cooling	23
6 Maintenance and trouble shooting	24
6.1 Recommended maintenance and quality assurance	24
6.2 Trouble shooting	25
6.3 Recoating/repainting of sensor surfaces	26
6.4 Calibration and checks in the field	26
7 Appendices	27
7.1 Appendix on uncertainty evaluation	27
7.2 Appendix on cable extension/replacement	28
7.3 Appendix on calibration hierarchy	28
7.4 Appendix on typical heat flux ranges	29
7.5 Appendix on measurement range	32
7.6 Appendix on sensor design: Gardon versus Schmidt-Boelter	32
7.7 EU declaration of conformity	33

List of symbols

quantities	symbol	unit
Heat flux	Φ	W/m ²
Voltage output	U	V
Sensitivity	S	V/(W/m ²)
Temperature	T	°C
Thermal resistance per unit area	R _{thermal,A}	K/(W/m ²)

subscripts

N/A

Introduction

HFS01 is an industrial water-cooled heat flux sensor engineered to withstand extreme radiative and convective heat flux levels. Its robust, all-metal body, high-temperature cabling, and IP67 rating deliver dependable measurements to withstand challenging conditions in industrial applications. A removable mounting flange simplifies robust, repeatable installation. It is designed for applications like metal furnaces, refractories, and concentrated solar power. To measure even higher heat flux levels, see also our **GG01** sensor.

HFS01 measures heat flux in the range of $(0 \text{ to } 800) \times 10^3 \text{ W/m}^2$, the extremely high fluxes in industrial applications. Equipped with a black absorber and water-cooled, it is designed to measure heat flux from radiative as well as convective sources. HFS01's thermopile sensor generates an output voltage proportional to the total absorbed heat flux. Also, a Type K thermocouple is included, to measure the sensor body temperature.

The sensor body must be kept cool. This is typically done by connecting it to tap water. The section of cabling closest to the sensor is a special high-temperature metal-sheathed cable with an interlocked spiral stainless-steel armor capable of withstanding temperatures up to 900 °C.

The low-temperature extension cable has a jacket of PTFE-type plastic. A removable flange can be used for mounting and is supplied with the sensor.

HFS01 can also be ordered without the black coating to reduce the sensor's absorption of radiation, while remaining sensitive to convective radiation.



Figure 0.1 HFS01 high heat flux sensor, pictured with and without its flange.

Common industrial applications

- metal furnaces
- refractories
- concentrated solar power

Next-level technology

HFS01 has several advantages:

- very robust all-metal instrument body and sensor for harsh conditions
- high-temperature signal cable to withstand extreme temperatures up to 900 °C
- signal wires electrically insulated from both the sensor body and cooling water

Calibration

HFS01 calibration is traceable to international standards. The factory calibration method follows the recommended practice of ASTM C1130-07 (2012).

Easy operation

Using HFS01 is simple. It connects directly to commonly used data logging systems. The heat flux, Φ (in W/m^2) is calculated by dividing the HFS01 output, a small voltage U , by the sensitivity S , which is provided on its product certificate. HFS01 is equipped with heavy-duty cabling and a fully stainless-steel casing, ensuring reliable performance in demanding environments.

The measurement function of HFS01 is:

$$\Phi = U/S$$

(Formula 0.1)

Figure 0.2 HFS01 is the sensor of choice for challenging environments in industrial applications



Trend monitoring and comparative measurement

HFS01 is often used for relative measurements using one sensor, i.e. monitoring of trends relative to a certain reference point in time or comparing heat flux at one location to the heat flux at another location. If the user wants to perform accurate absolute measurements with HFS01, as opposed to relative measurements, the user must make his own uncertainty evaluation and correction for systematic errors. See the appendix on uncertainty evaluation. However, in many situations the analysis of trends is sufficient. In that case a high absolute measurement accuracy is not needed, and a formal uncertainty evaluation is not necessary.

Options

- longer cable (specify total length for both cable types in meters)
- connector at the HFS01 cable end
- chassis connector with wiring (color-coded to match the cable)
- low-temperature extension cable with 2 connectors: matching the cable connector and the chassis connector
- blank metal sensor surface (no coating)

See also

- **GG01** Gardon gauge water-cooled high heat flux sensor for measurements up to $2500 \times 10^3 \text{ W/m}^2$
- **SBG04** water-cooled sensor—for cone calorimeters
- **SBG01** water-cooled heat flux sensor with a 1-inch body for measurements $< 200 \times 10^3 \text{ W/m}^2$

1 Ordering and checking at delivery

1.1 Ordering HFS01

The standard configuration of HFS01 is with 1 meter high-temperature cable and 3 meters low-temperature extension cable.

Common options are:

- longer cable (specify total cable length for both cable types in m)
- blank metal sensor surface, no coating
- connector at HFS01 cable end
- extension cable with 2 connectors matching cable connector and chassis connector (specify cable length in m)
- chassis connector with internal wiring (color code of wiring identical to cable color code)

1.2 Included items

Arriving at the customer, the delivery should include:

- heat flux sensor HFS01
- mounting flange
- cable of the lengths as ordered
- any other option as ordered
- product certificate matching the instrument serial number



Figure 1.2.1 HFS01 showing its metal body, black coating and cable. The removable flange is included but not pictured here.

1.3 Quick instrument check

A quick test of the instrument can be done by connecting it to a multimeter.

1. Check the electrical resistance of the heat flux sensor between the black [-] and red [+] wires and the thermocouple between the green [+] and white [-] wires. Use a multimeter at the 100 Ω range. Measure the sensor resistance first with one polarity, then reverse the polarity. Take the average value. Typical resistance should be the nominal sensor resistance of 3 Ω for the thermopile sensor plus 0.2 Ω /m (resistance per meter cable) for the total resistance of two wires (back and forth added). For the thermocouple work with 3 Ω /m resistance per meter cable. Infinite resistance indicates a broken circuit; zero or a lower than 1 Ω resistance indicates a short circuit.
2. Check if the heat flux sensor reacts to heat: put the multimeter at its most sensitive range of DC voltage measurement, typically the 100×10^{-3} VDC range or lower. Expose the sensor heat, for instance touching it with your hand. The signal should read $> 2 \times 10^{-3}$ V now. Exposing the side flush with flanges should generate a positive signal, doing the same at the opposite side, the sign of the output voltage reverses. Also look at the reaction of the thermocouple to heat. The thermocouple is located at the side flush with the flanges.
3. Inspect the instrument for any damage.
4. Check the sensor serial number engraved on the sensor side against the certificate provided with the sensor.

2 Instrument principle and theory

2.1 Instrument principle and theory

The HFS01 heat flux sensor measures radiation received by a plane surface from a 180° field of view angle. This quantity, expressed in W/m^2 , is called irradiance, and informally also heat flux. HFS01 is designed to measure high heat fluxes, in the order of up to $800 \times 10^3 W/m^2$. The radiation spectrum of such sources typically extends from 300 to $3000 \times 10^{-9} m$. By definition, a heat flux sensor should cover that spectral range with a spectral selectivity that is as "flat" as possible.

Using an open detector, HFS01 is also sensitive to convective heat flux. This contribution is usually ignored, but may actually be significant: for example with concentrated flames from welding equipment or rockets.

In an irradiance measurement by definition the response to "beam" radiation varies with the cosine of the angle of incidence; i.e. it should have full response when the radiation hits the sensor perpendicularly (normal to the surface, 0° angle of incidence), zero response when the radiation has 90° angle of incidence, and 50 % of full response at 60° angle of incidence.

A heat flux sensor should have a so-called "directional response" (older documents mention "cosine response") that is as close as possible to the ideal cosine characteristic.

In order to attain the proper directional and spectral characteristics, a heat flux sensor's main components are:

- A thermal sensor with black coating. It has a flat spectrum covering the 200 to $50000 \times 10^{-9} m$ range, and has a near-perfect directional response. The coating absorbs all radiation and, at the moment of absorption, converts it to heat. The heat flows through the internal thermopile sensor to the metal body. The thermopile sensor generates a voltage output signal that is proportional to the irradiance.
- A water-cooled all-metal body. This body acts as a heat sink.

HFS01 users typically assume that the measured heat flux is representative of the undisturbed irradiance at the location of the sensor. Users may also apply corrections based on scientific judgement.

The heat flux sensor in HFS01 is a thermopile. This thermopile measures the temperature difference across the sensor surface and the water-cooled stainless-steel body of HFS01. Working completely passive, the thermopile generates a small voltage that is a linear function of this temperature difference. The heat flux is proportional to the same temperature difference divided by the effective thermal conductivity of the heat flux sensor body.

Using HFS01 is easy. For read-out the user only needs an accurate voltmeter that works in the millivolt range. To convert the measured voltage, U , to a heat flux Φ , the voltage must be divided by the sensitivity S , a constant that is supplied with each individual sensor.

Heat flux sensors such as HFS01 are typically calibrated under the following reference conditions:

- conductive heat flux (as opposed to radiative or convective heat flux)
- homogeneous heat flux across the sensor

The HFS01 factory calibration procedure uses the following reference conditions:

- sensor temperature 30°C (at a cooling water temperature of 10 °C)
- heat flux of $23 \times 10^3 \text{ W/m}^2$
- water cooling
- calibrated for absorbed heat flux

Unique features of HFS01 are:

- robustness, including a high-temperature cable
- suitable for use at high heat fluxes up to $800 \times 10^3 \text{ W/m}^2$
- built-in temperature sensor; type K thermocouple
- IP protection class: IP67
- sensor signal wires electrically isolated from housing and from cooling water

2.2 Detailed measurement equation

Measuring with heat flux sensors, errors may be caused by differences between calibration reference conditions and the conditions during use. The user should analyze his own experiment and make his own uncertainty evaluation.

In more detail, the measurement equation of HFS01 is

$$\Phi = U/S + \sigma \cdot (T + 273.15)^4 \quad (\text{Formula 2.2.1})$$

In which the first term represents the incoming irradiance, and the second term represents the irradiance emitted by the sensor. The constant σ is the Stefan-Boltzmann constant $5.67 \times 10^{-8} \text{ W}/(\text{m}^2 \cdot \text{K}^4)$.

In case the cooling water temperature is in the order of 20 °C, at the thermal resistance of HFS01, the second term ($\sigma \cdot (T + 273.15)^4$) is of the order of $25 \times 10^3 \text{ W/m}^2$. This is usually considered negligible with a heat flux of $800 \times 10^3 \text{ W/m}^2$, so that the measurement Equation 2.1.1 is abbreviated to:

$$\Phi = U/S \quad (\text{Formula 0.1})$$

Comments on the most common error sources can be found in the Appendix on uncertainty evaluation.

The HFS01 calibration reference temperature is 30 °C. In practice, the sensitivity of an HFS01 may depend on the temperature of the sensor.

Based on the thermal conductivity of the sensor material as a function of temperature, the thermal expansion of the sensor materials, and the Seebeck coefficient of the thermocouple as a function of temperature, we find a theoretical value for the temperature dependence of the sensitivity of -0.0005 1/K.

Users may wish to correct for this temperature dependence. To correct for the temperature dependence of the sensitivity, use the measurement function

$$\Phi = U/(S \cdot (1 - 0.0005 \cdot (T - 30))) \quad (\text{Formula 2.2.2})$$

with Φ the heat flux in W/m^2 , U the HFS01 voltage output in V, S the sensitivity in $V/(W/m^2)$ at 30 °C and T the HFS01 temperature in °C.

The sensitivity S is shown on the product certificate, delivered with HFS01.

HFS01 is calibrated for received heat flux. In case the heat flux is predominantly radiative, users may choose to correct for the absorption of the black absorber paint:

$$\Phi = U/(0.92 \cdot S \cdot (1 - 0.0005 \cdot (T - 30))) \quad (\text{Formula 2.2.2})$$

3 Specifications of HFS01

HFS01 measures the heat flux density through the surface of the sensor. This quantity, expressed in W/m^2 , is called heat flux. HFS01 is rated for heat flux levels up to $800 \times 10^3 W/m^2$. It also measures the instrument body temperature. HFS01 is passive, using thermopile and thermocouple sensors. The thermopile generates a small output voltage proportional to the heat flux. Using an open detector, HFS01 is sensitive to both radiative and convective heat flux. The sensor must be water-cooled. HFS01 can only be used in combination with a suitable measurement system. It is supplied with a traceable calibration.

Table 3.1.1 Specifications of HFS01 (continued on next pages).

HFS01 specifications	
sensor type	heat flux sensor
heat flux sensor	thermopile
measurand	heat flux
measurand in SI units	heat flux density/irradiance in W/m^2
measurement range	0 to $800 \times 10^3 W/m^2$
measurement function/required programming	$\Phi = U/S$
optional measurement function/required programming for correction of sensitivity as a function of instrument body temperature	$\Phi = U/(S \cdot (1 - 0.0005 \cdot (T - 30)))$
optional measurement function/required programming for correction of sensitivity as a function of instrument body temperature and black coating absorption	$\Phi = U/(0.92 \cdot S \cdot (1 - 0.0005 \cdot (T - 30)))$
sensitivity range	5 to $15 \times 10^{-9} V/(W/m^2)$
sensitivity (nominal)	$9 \times 10^{-9} V/(W/m^2)$
directional sensitivity	heat flux on the front surface generates a positive voltage output signal
full field of view angle	180°
spectral range	1 to $50 \times 10^{-6} m$

sensing area diameter	40 x 10 ⁻³ m
black coated surface	Rust-Oleum® BBQ & Stove enamel
black coating emissivity	0.92 (estimate)
response time (95%)	60 s (nominal)
output signal	DC voltage
output voltage signal range	multiply the sensitivity by the maximum expected heat flux
measurand	temperature
measurand in SI units	sensor body temperature in °C
temperature sensor	thermocouple type K
temperature sensor specification	EN 60584-1:2013 ASTM E230 / E230M-12
rated operating temperature range	-30 to +900 °C (high-temperature cable) -30 to +650 °C (sensor and black surface coating) -30 to +240 °C (low-temperature extension cable)
required read-out	heat flux sensor: 1 x differential voltage channel or 1 x single ended voltage channel temperature sensor: 1 x Type K differential thermocouple channel or 1 x Type K single ended thermocouple channel, both with input resistance > 10 ⁶ Ω
required sensor power	zero (passive sensor)
rated operating pressure range	sea level ambient air pressure, not suitable for use in vacuum
rated operating relative humidity range	0 to 100 % (non-condensing)
IP protection class	IP67
temperature dependence	-0.0005 1/K (see appendix)
non-linearity	included in temperature dependence
non-stability	< 1%/yr (for typical use)

heat flux sensor resistance (nominal)	100 Ω (standard cable lengths)
temperature sensor resistance (nominal)	60 Ω (standard cable lengths)
sensor thickness	6×10^{-3} m
sensor thermal resistance	0.4×10^{-3} K/(W/m ²)
sensor thermal conductivity	15 W/(m·K)
coating thickness	0.05×10^{-3} m
coating thermal resistance	0.2×10^{-3} K/(W/m ²) (estimate)
standard cable lengths	
– high-temperature cable	1 m (see options)
– low-temperature extension cable	3 m (see options)
high-temperature cable type	flexible high-temperature metal-sheathed cable with interlocked spiral stainless-steel armor
low-temperature extension cable type	PTFE
high-temperature cable: heat flux sensor cable resistance	110 Ω /m (nominal)
low-temperature extension cable: heat flux sensor cable resistance	0.1 Ω /m (nominal)
low-temperature extension cable: temperature sensor cable resistance	3 Ω /m (nominal)
high-temperature cable: temperature sensor cable resistance	50 Ω /m (nominal)
high-temperature cable diameter	5×10^{-3} m
low-temperature extension cable diameter	4.5×10^{-3} m
transition piece diameter	10×10^{-3} m
marking	1 x engraving on the transition piece, showing serial number
gross weight including 1 and 3 m cable	approx. 1 kg
net weight including 1 and 3 m cable	approx. 1 kg
packaging	plastic case

Water cooling

typical cooling method	tap water at 3 bar supplied through and drained through a silicone hose
alternative cooling method	actively cooling water circulator with water pump instead of tap water
rated exposure time interval	indefinite when water cooled
rated cooling water operating pressure range	0 to 10 bar
rated cooling water flow	> 30 l/hr (0.01 l/s), preferably 100 l/h (0.03 l/s)
rated cooling water temperature range	10 to 30 °C
recommended tubing for cooling water supply	through 10 x 10 ⁻³ m outer diameter / 5.5 x 10 ⁻³ m inner diameter silicone hose. Outer diameter of metal tubes on sensor body: 6 x 10 ⁻³ m
recommended coupling for tubing	type MCD1704 BODY 1/4 inch NPT+MCD4204 INSERT see for such an item the colder catalogue via www.cpcworldwide.com

Installation and use

typical conditions of use	In experiments, in industrial research environments. Exposed to high heat fluxes for periods of several minutes to several days. Connected to user-supplied data acquisition equipment. Regular inspection of the sensor surface, housing and water supply. Continuous monitoring of sensor temperature and water supply. No special requirements for immunity, emission, chemical resistance.
installation	See recommendations in this user manual. Avoid mechanical force on the sensor surface, sensor body and sensor-to-cable transition.
permanent installation	Using the included mounting flange is recommended.
cable extension	Use the Hukx HFS01 extension cable with 2 connectors matching cable connector and chassis connector (specify cable length in m).
recoating	repainting of sensors is possible, according to manufacturer recommendations. After repainting, the sensors must be re-calibrated

Calibration

calibration traceability	to SI units
product certificate	included (showing calibration result and traceability)
calibration method	calibrated for absorbed heat flux, method IHFC, according to ASTM C1130
calibration reference conditions	30 °C, heat flux of $23 \times 10^3 \text{ W/m}^2$
calibration hierarchy	from SI through international standards and through an internal mathematical procedure
calibration uncertainty	$< \pm 10 \% (k = 2)$
validity of calibration	Based on experience the instrument sensitivity will not change during storage. During use, the instrument "non-stability" specification is applicable
field calibration	Is possible by comparison to a calibration reference sensor. Usually mounted side by side. Preferably reference and field sensor of the same model and brand.
temperature sensor tolerance class	IEC 60584-1:2013: type K, tolerance class 1
temperature sensor error limits	according to IEC 60584-1: 2013 or ASTM E230 / E230M-12

Measurement accuracy

uncertainty of the measurement	statements about the overall measurement uncertainty can only be made on an individual basis. see the chapter on uncertainty evaluation.
--------------------------------	--

Versions/options

order code standard version	HFS01 high heat flux sensor, with 1 m high-temperature cable and 3 m low-temperature extension cable
without coating	blank metal surface, no coating
longer cables	longer cables (specify total cable length for both cable types in m)
extension cable	extension cable with 2 connectors matching cable connector and chassis connector (specify cable length in m)

connector

connector at HFS01 cable end

chassis connector

chassis connector with internal wiring
(color code of wiring identical to cable color code)

Accessories

spare part

mounting flange

3.1 Dimensions of HFS01

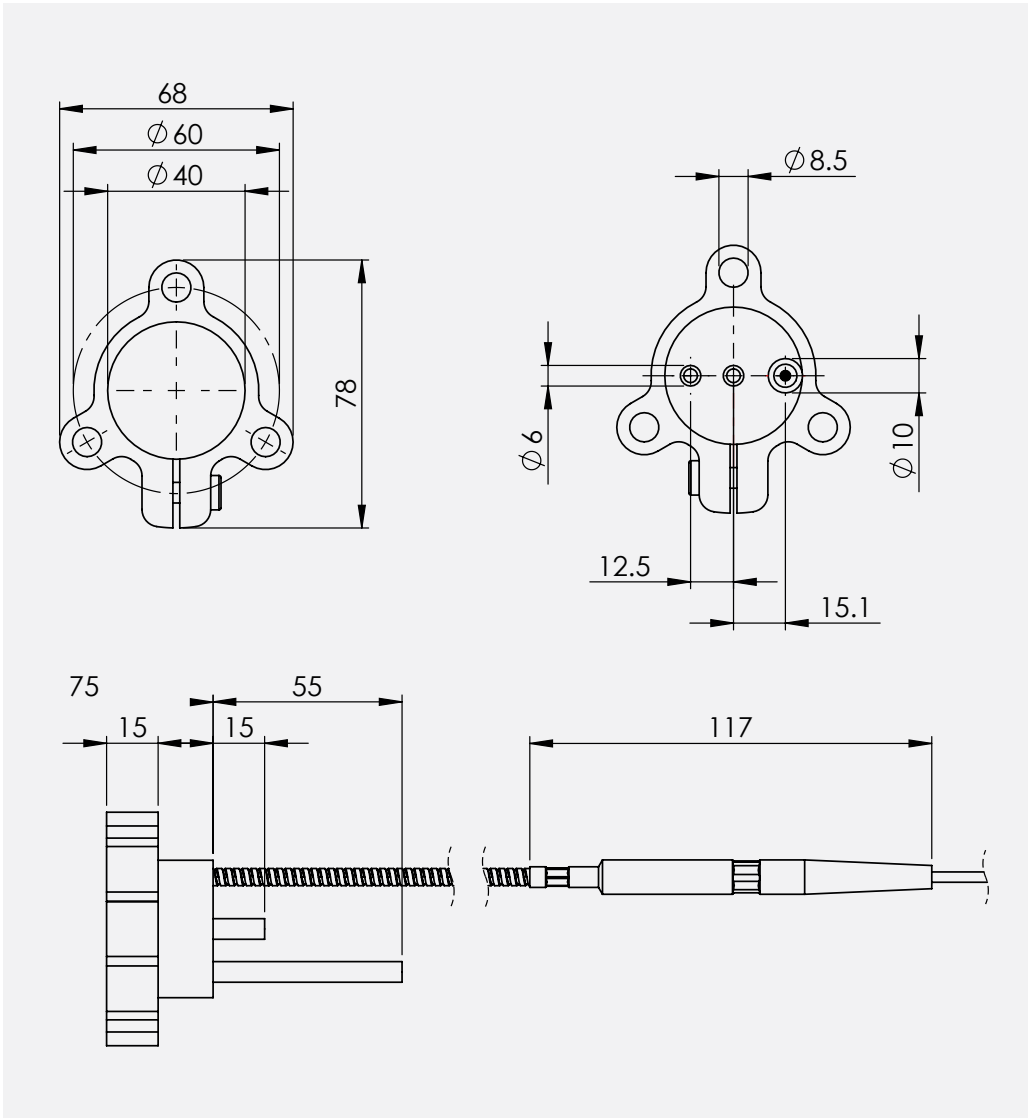

Figure 3.2.1 HFS01 high heat flux sensor dimensions in $\times 10^{-3}$ m.

4

Standards and recommended practices for use

HFS01 should be used in accordance with the recommendations of this user manual.

- See the typical conditions of use in the specifications; discuss any deviations.
- Measure or otherwise inspect the water supply; stop the measurement in case water supply fails
- Measure or otherwise inspect the sensor temperature; stop the measurement in case the sensor temperature exceeds 600 °C.

5 Installation of HFS01

5.1 Installation

Table 5.1.1 Recommendations for installation.

location	Choose a location that is representative of the process that is analyzed.
standard operating practices	If the test is carried out in accordance to a standard: look for recommendations in the standard.
orientation	Direct the sensor surface towards the source of radiation to be studied.
exposure	Expose the sensor to the heat flux that must be measured, limit as much as possible exposure of the sides of the sensor and exposure of the signal cable and water supply tubing. Users typically mount HFS01 using a thermal shield with a 40 mm hole in it.
water cooling	Usually tap water is used, supplied and led out through silicone hoses with a recommended outer diameter of 10×10^{-3} m and an inner diameter of 5.5×10^{-3} m. Monitor the water supply flow, and stop the experiment in case it is too low. See the chapter on cooling for more information.
sensor temperature	Monitor the sensor temperature. Stop the experiment in case it is too high.
electrical connection	The sensor and thermocouple both generate a small voltage output signal. No power supply is required. Connect the conductors to a data acquisition system. See the chapter on electrical connection.
signal amplification	See the paragraph on electrical connection.
mechanical mounting	Use the flange for mounting the sensor; use the three holes in the flange for mounting the flange. Make sure that the object that is used for mounting the flange remains relatively cool. Heat should not conduct easily through the flange to the sensor body. Provided cables with an additional strain relief.
heat shielding	Shield the sensor body and cable as much as possible from radiated and convective heat. Recommended is to keep the shielding and sensor mount thermally isolated. See figure below.

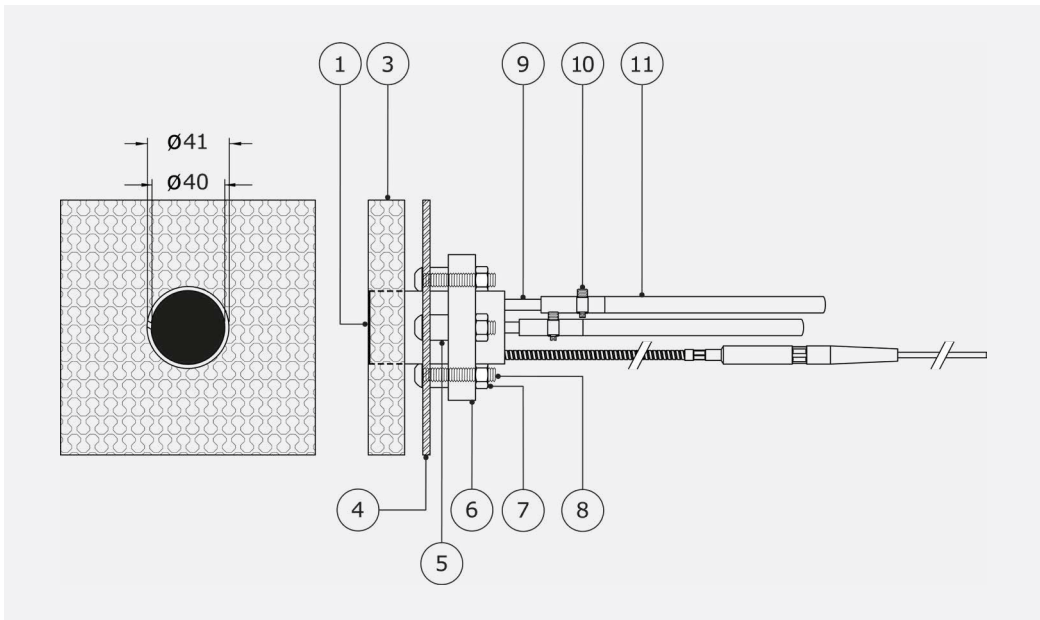

Figure 5.1.2 Recommended installation of HFS01

The picture above shows the recommended installation of HFS01 using mechanical mounting, heat shielding and water cooling.

- 1. sensor surface
- 2. shield
- 3. sensor body
- 4. mounting plate
- 5. spacer
- 6. flange
- 7. M8 nut
- 8. M8 bolt
- 9. water tube (IN)
- 10. water tube (OUT)
- 11. hose clamp
- 12. water hose

5.2 Electrical connection

A heat flux sensor should be connected to a measurement system, typically a so-called data logger . HFS01 is a passive sensor that does not need any power, neither for the heat flux sensor, nor for the temperature sensor. Cables may act as a source of distortion, by picking up capacitive noise. We recommend keeping the distance between a data logger or amplifier and the sensor as short as possible. For cable extension, see the appendix on this subject.

Table 5.2.1 The electrical connection of HF05. The shield is not connected to the stainless-steel sensor body.

wire	signal
red	heat flux signal [+]
black	heat flux signal [-]
green	thermocouple type K [+]
white	thermocouple type K [-]
gray	shield

5.3 Requirements for data acquisition/amplification

Table 5.3.1 Requirements for data acquisition and amplification equipment for HFS01 in the standard configuration.

capability to measure small voltage signals	preferably: $< 5 \times 10^{-6}$ V uncertainty minimum requirement: 20×10^{-6} V uncertainty (valid for the entire expected temperature range of the acquisition/amplification equipment)
capability for the data logger or the software	to store data, and to perform division by the sensitivity to calculate the heat flux. $\Phi = U/S$ (Formula 0.1)
capability to measure thermocouple type K	preferably: measurement uncertainty within ± 3 °C
data acquisition input resistance	$> 1 \times 10^6 \Omega$
open circuit detection (WARNING)	Open circuit detection should not be used, unless this is done separately from the normal measurement by more than 5 times the sensor response time and with a small current only. Thermopile and thermocouple sensors are sensitive to the current that is used during open circuit detection. The current will generate heat, which is measured and will appear as a temporary offset.

The selection and programming of data loggers is the responsibility of the user. Please contact the supplier of the data acquisition and amplification equipment to see if directions for use with the HFS01 are available.

5.4 Cooling

For normal applications, the standard 3 bar pressure of tap water supply is sufficient for operating heat flux meters such as HFS01. Absorbed power is in the order of 500 W at $400 \times 10^3 \text{ W/m}^2$ and 1000 W at $800 \times 10^3 \text{ W/m}^2$.

As water has a very high heat capacity, a water supply of 100 l/hr or 0.03 l/s is sufficient for $40 \times 10^{-3} \text{ m}$ or (1.5 inch) diameter sensors to carry away all the generated heat with a temperature rise of the cooling water of less than 30 °C, taking a safety factor of 4. An alternative possibility is to use a large vessel filled with water or coolers with a cooling capacity of at least 1 kW, such as recirculating cooler model FL1201 supplied by the Julabo company. The Julabo equipment is a closed-circuit water cooler with a convective heat exchanger.



Figure 5.4.1 Example of an active water cooler with a pump: Julabo FL1201.

6 Maintenance and trouble shooting

6.1 Recommended maintenance and quality assurance

HFS01 is typically located in hostile environments in which the sensor is under constant threat of being damaged. Unreliable measurement results are detected by very frequent recalibration, by visual inspection of the sensor and by scientific judgement, for example by looking for unreasonably large or small measured values. If possible, cooling water flow and sensor temperature should be measured.

Table 6.1.1 Recommended maintenance of HFS01.

Minimum recommended heat flux sensor maintenance			
	interval	subject	action
1	before and after every test	inspection	Inspect sensor coating, cable quality, inspect mounting, inspect the water supply tubing.
2	after every test	data review	Judge the feasibility of the measurement data compare to measurements with other sensors, typically heat flux and temperature measurements.
3	after every test	lifetime assessment	Judge if the instrument will be reliable for another test, consider re-painting the sensor surface.
4	at least every 2 years and after re-painting	calibration	Recalibrate against a local reference or at the manufacturer.

6.2 Trouble shooting

Table 6.2.1 Trouble shooting for HFS01. (continued on the next page).

general	<p>Inspect the sensor for any damage. Inspect the quality of mounting/installation. Inspect if the wires are properly attached to the data logger.</p> <p>Check the condition of the cable.</p> <p>Inspect the connection of the shield (typically connected at the data logger side)</p> <p>Check the data logger program, in particular if the right sensitivity is entered.</p> <p>HFS01 serial number is engraved on the side of the sensor body. The sensitivity can be found on the product certificate.</p> <p>Check the electrical resistance of the heat flux sensor, preferably when no significant heat flux is present, between the black [-] and red [+] wires and the thermocouple between the green [+] and white [-] wires. Measure the sensor resistance first with one polarity, then reverse the polarity. Take the average value. Compare the results with the resistance values on the product certificate or estimated from the sensor specifications and cable lengths. Infinite resistance indicates a broken circuit; zero or a lower than 1 Ω resistance indicates a short circuit.</p>
The sensor does not give any signal.	<p>Check if the sensor reacts to heat: put the multimeter at its most sensitive range of DC voltage measurement.</p> <p>Expose the sensor to a strong heat source, for instance using a heat gun. Exposing the sensor surface should generate a positive signal.</p> <p>Also look at the reaction of the thermocouple to heat.</p> <p>Check the data acquisition by replacing the sensor with a spare unit.</p>
The sensor signal is unrealistically high or low.	<p>Check the cable condition looking for cable breaks.</p> <p>Check the data acquisition by applying a 1×10^{-6} V source to it in the 1×10^{-6} V range.</p> <p>Look at the measurement result. Check if it is as expected.</p> <p>Check the data acquisition by short circuiting the data acquisition input with a 10 Ω resistor. Look at the output. Check if the output is close to 0 W/m².</p>
The sensor signal shows unexpected variations.	<p>Check the presence of strong sources of electromagnetic radiation (radar, radio).</p> <p>Check the condition and connection of the shield.</p> <p>Check the condition of the sensor cable.</p> <p>Check if the cable is not moving during the measurement.</p>

6.3 Recoating/repainting of sensor surfaces

ISO 14934-4 Paragraph 9.1 allows repainting of sensors, according to manufacturer recommendations. Hukx recommendations are:

Repainting is preferably done by the manufacturer. Do-it-yourself repainting is possible but if that is done all product warranties are cancelled. Purchase a matt (not glossy) black paint which is temperature resistant up to at least 650 °C, for example Rust-Oleum® BBQ & Stove enamel. Silicone based black paints are also a good choice. Aerosol spray cans are the easiest to use, but paint from a can will work as well. Acetone is typically a good solvent for these paints in case a solvent is needed. Surface preparation: In case the existing sensor surface coating has small scratches but is otherwise in good condition, do not clean, but apply new paint directly to the existing paint. In case of heavy damage to sensor surface coatings: remove the existing coating, clean with acetone or ethanol. You may use a fine grade sand paper. Paint application: tape the sides and use the standard method of spraying. Recalibration: newly coated sensors should be recalibrated. We do not expect significant (> 5 %) changes relative to the original sensitivity.

6.4 Calibration and checks in the field

The recommended calibration interval of heat flux sensors is 2 years. Recalibration of field heat flux sensors is ideally done by the sensor manufacturer.

On-site field calibration is possible by comparison to a calibration reference sensor, usually mounted side by side.

Hukx main recommendations for field calibrations are:

1. to compare to a calibration reference of the same brand and type as the field sensor
2. to connect both to the same electronics, so that electronics errors (also offsets) are eliminated.
3. to mount all sensors on the same platform, or if the heat flux is not homogeneous; exchange positions a few times.
4. typical duration of test: > 20 min
5. typical heat fluxes used for comparison: > $5 \times 10^3 \text{ W/m}^2$, preferably > $20 \times 10^3 \text{ W/m}^2$
6. to correct deviations of more than $\pm 20 \%$. Lower deviations should be interpreted as acceptable and should not lead to a revised sensitivity.

7 Appendices

7.1 Appendix on uncertainty evaluation

In many situations the analysis of trends is sufficient. In that case a high absolute measurement accuracy is not needed, and a formal uncertainty evaluation is not necessary.

The measurement uncertainty is a function of:

- calibration uncertainty, including uncertainty of the absorption coefficient (now put to 0.92)
- differences between reference conditions during calibration and measurement conditions, for example uncertainty caused by temperature dependence (including non-linearity)
- damage during sensor employment
- application errors: the measurement conditions and environment in relation to the sensor properties, the influence of the sensor on the measurand, the representativeness of the measurement location

It is not possible to give one figure for heat flux sensor measurement uncertainty. Statements about the overall measurement uncertainty can only be made on an individual basis, taking all these factors into account.

7.1.1 Contributions to the uncertainty budget

7.1.1.1 Calibration uncertainty at Hukx

HFS01's factory calibration uncertainty under reference conditions is $\pm 10\%$ with a coverage factor $k = 2$. This calibration is for received heat flux. In case you have radiative heat flux you may correct using an absorption of 0.92.

7.1.1.2 Uncertainty caused by temperature dependence and non-linearity

The temperature dependence and non-linearity are corrected by using a temperature dependence of $-0.0005 [1/K]$. We estimate that the uncertainty of this correction is $\pm 50\%$. This means that at a heat flux of $400 [x 10^3 W/m^2]$, at which a correction of the sensitivity of around -12.5% is expected, we expect the correction to be in the range from -6.2% to -18.8% .

7.2 Appendix on cable extension/replacement

HFS01 is equipped with a high-temperature cable and a low-temperature extension cable. The standard configuration of HFS01 is with 1 m high-temperature cable and 3 m low-temperature extension cable. Cable length of both cable types can be specified when ordering. Also other lengths than the standard cable lengths are optionally available. After manufacturing, the high-temperature cable cannot be extended by the user. The low-temperature cable can, also after ordering, be extended, either by using extension cables with connectors supplied by the manufacturer, or by using general-purpose copper and type K thermocouple wire.

Keep the distance between data logger or amplifier and sensor as short as possible. Cables may act as a source of distortion by picking up capacitive noise. In an electrically "quiet" environment the HFS01 cable may be extended without problem to 30 meters. If done properly, the sensor signal, although small, will not significantly degrade because the sensor resistance is very low (which results in good immunity to external sources) and because there is no current flowing (so no resistive losses). Cable and connection specifications are summarized in table 7.2.1.

Table 7.2.1 Preferred specifications for cable extension of HFS01.

cable	Hukx HFS01 high-temperature cable (not extendable) Hukx HFS01 low-temperature extension cable
extension	Use Hukx HFS01 extension cable with 2 connectors matching cable connector and chassis connector (specify cable length in m) Use Hukx chassis connector
outer diameter	4.5×10^{-3} m (low-temperature extension cable)
length	cables should be kept as short as possible, in any case the total cable length should be less than 50 m

7.3 Appendix on calibration hierarchy

HF05 factory calibration is traceable from SI through international standards and through an internal mathematical procedure which corrects for known errors. The formal traceability of the generated heat flux is through voltage and current to electrical power and electric power and through length to surface area.

The Hukx HFC method follows the recommended practice of ASTM C1130. It relies on a thin heater apparatus according to principles as described in Paragraph 4 of ASTM C1114-06, in the single sided mode of operation described in Paragraph 8.2 and in ASTM C1044.

7.4 Appendix on typical heat flux ranges

Irradiance from blackbody covering 180° full field of view angle.

Table 7.4.1 Irradiated heat flux versus equivalent blackbody source temperature calculated using Stefan Boltzmann's law.

	x 10³ W/m²	equivalent blackbody temperature °C
1	0.4	10
2	20	500
3	60	750
4	150	1000
5	300	1250
6	550	1500
7	1000	1750
8	1500	2000

An indication of allowable heat flux levels for personnel and equipment can be found below.

Table 7.2.1 Allowable heat flux levels in industrial environments.

		x 10³ W/m²	BTU/(hr-ft²)
1	equipment	9.5	3000
2	human: run	6.3	2000
3	human: walk	4.7	1500
4	human: work (static)	1.6	500

Table 7.2.2 typical ranges of heat flux levels, from ISO 14934-4.

	x 10³ W/m²	Comment
1	300	maximum level in a fully developed fire
2	200 to 100	incident heat flux on the wall in a developed fire enclosure
3	about 100	radiation from burning house
4	about 30	causing ignition of tree
5	20 to 10	causing ignition of timber
6	about 7 or 8	lowest level for causing ignition of a timber wall under a pilot flame
7	about 4	lowest level for causing a burn
8	about 2,5	highest level for people to endure
9	1,5	solar constant, maximum level of solar irradiance

Table 7.4.4 Typical ranges of heat flux levels, from ISO 5569.

	x 10³ W/m²	Comment
1	300	jet fire peak
2	200	jet fire average and fully developed fire > 10 x 10 ⁶ W
3	140	premixed blow torches oxyacetylene
4	120 to 145	peak floor values in post flashover room fires
5	115 to 230	peak wall values in post flashover room fires
6	105 to 175	peak ceiling values for post flashover room fires
7	90 to 200	average wall values for post flashover room fire
8	70 to 150	average ceiling values for post flashover room fire
9	50 to 150	high ventilation fully developed room fire 5 % to 10 % O ₂ by volume
10	60 to 120	premixed gas burner
11	40 to 115	on facade 0,8 m to 3,3 m above window at lintel
12	40 to 70	low ventilation fully developed fire 1 % to 5 % O ₂ by volume
13	30 to 40	small (up to 250 mm high) gas diffusion flames
14	25 to 45	flux on wall from vertical wall burning
15	25	flux below vertical spreading wall flame
16	< 25	oxidative pyrolysis fire 5 % to 21 % O ₂ by volume
17	20 to 40	developing fire with 10 % to 15 % O ₂ by volume
18	20 to 25	heat flux at floor level in flashover fire with ceiling temperature > 600 °C
19	18 to 20	match flames
20	10 to 40	output from waste paper basket fires
21	12 to 22	critical ignition flux of many materials, e.g. polyethylene, polyacetal, PMMA, wood, hardboard

7.5 Appendix on measurement range

The measurement range of the HFS01 is specified up to $800 \times 10^3 \text{ W/m}^2$ at 10 to 30 °C cooling water temperature. This is a very conservative specification.

The maximum temperature of 650 °C of the black absorber paint is the limiting specification. The sensor temperature T in °C in a specific situation depends on the cooling water temperature T_{heatsink} in °C, the heat flux Φ in W/m^2 and the thermal resistance per unit area $R_{\text{thermal,A}}$ of the sensor plus black absorber paint in $\text{K}/(\text{W/m}^2)$.

$$T = T_{\text{heatsink}} + \Phi \cdot R_{\text{thermal,A}} \quad (\text{Formula 7.5.1})$$

This means the measurement range is lower for higher heat sink temperatures.

$$\Phi_{\text{maximum}} = (650 - T_{\text{heatsink}}) / R_{\text{thermal,A}} \quad (\text{Formula 7.5.2})$$

Taking a worst-case scenario of a maximum cooling water temperature of 100 °C and a thermal resistance of $0.65 \text{ K}/(\text{W/m}^2)$, we arrive at a maximum heat flux rating of $800 \times 10^3 \text{ W/m}^2$.

7.6 Appendix on sensor design: Gardon versus Schmidt-Boelter

The general name for the HFS01 type sensor is nowadays "total heat flux meter": according to ISO 14934-1 Paragraph 3 definition 3.17, and Annex A.2. The so-called Gardon and Schmidt-Boelter designs (named after their inventors) are also "total heat flux meters". From a metrology point of view there is no difference. They all measure heat flux and are traceable to the same reference. The discussion what design to use is not relevant. New standards in fire testing will probably avoid using the Gardon or Schmidt-Boelter names.

7.7 EU declaration of conformity

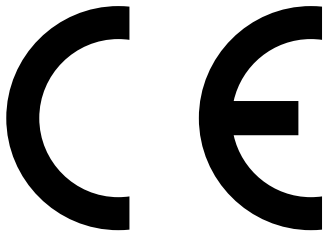

We, Hukseflux Thermal Sensors B.V.,
Delftechpark 31, 2628 XI, Delft,
The Netherlands

in accordance with the requirements of the following directives:

2011/65/EU The Restriction of Hazardous Substances Directive

hereby declare under our sole responsibility that:

Product models	HFS01
Product type	heat flux sensor
Brand name	Hukx

has been designed to comply and is in conformity with the relevant sections and applicable requirements in the directive under the typical conditions of use as defined in product specifications.

A handwritten signature in blue ink, appearing to be 'Eric Hoeksema', written over a light blue grid background.

Eric HOEKSEMA
Director
Delft, 01 March 2016

About Hukx

Hukx is the leading innovator in solar radiation and heat flux sensor technology. We are proud to set the standard in high-accuracy measurement, and to be working at the heart of the energy transition.

Customers worldwide rely on our bestselling pyranometers and heat flux sensors. From sensor design and selection to supply and recalibration, we support you across the entire lifecycle.

Hukx is headquartered in the Netherlands, with locally owned representative sales offices in the USA, Brazil, India, China, Southeast Asia, and Japan.

Let us help you select the best sensor for your application. Get in touch with our experts today via: info@hukx.com

© Hukx

v2510

We reserve the right to change specifications without prior notice.

www.hukx.com

HUKX