

**HUKX**

Sensor  
Technology

User manual  
Self-calibrating  
heat flux sensor™

**HFP01SC**

# Warning statements



Putting more than 12 Volt across the sensor wiring can lead to permanent damage to the sensor.



Putting more than 20 Volt across the heater wiring can lead to permanent damage to the heater.



Do not use "open circuit detection" when measuring the sensor output.

# Contents

<b>Introduction</b>	<b>5</b>
<b>1 Ordering and checking at delivery</b>	<b>8</b>
1.1 Ordering HFP01SC	8
1.2 Included items	8
1.3 Quick instrument check	8
<b>2 Instrument principle and theory</b>	<b>9</b>
2.1 General heat flux sensor theory	9
2.2 The self-test and self-calibration	11
2.3 Programming the self-test and self-calibration	12
<b>3 Specifications of HFP01</b>	<b>15</b>
3.1 Specifications of HFP01SC	15
3.2 Dimensions of HFP01SC	18
<b>4 Standards and recommended practices for use</b>	<b>19</b>
<b>5 Installation of HFP01SC</b>	<b>22</b>
5.1 Site selection and installation	22
5.2 Electrical connection	24
5.3 Requirements for data acquisition/amplification	26
<b>6 Making a dependable measurement</b>	<b>27</b>
6.1 Uncertainty evaluation	27
6.2 Typical measurement uncertainty budget	28
6.3 Contributions to the uncertainty budget	29
<b>7 Maintenance and trouble shooting</b>	<b>31</b>
7.1 Recommended maintenance and quality assurance	31
7.2 Trouble shooting	32
7.3 Calibration and checks in the field	33
<b>8 Appendices</b>	<b>34</b>
8.1 Appendix on cable extension/replacement	34
8.2 Appendix on standards for calibration	35
8.3 Appendix on calibration hierarchy	35
8.4 Electrical connection of HFP01SC supplied by Campbell Scientific USA	36
8.5 EU declaration of conformity	37

# List of symbols

## quantities

heat flux  
 voltage output  
 sensitivity  
 temperature  
 temperature difference  
 time constant  
 time  
 thermal conductivity  
 thermal resistivity  
 volumetric heat capacity  
 resistance  
 storage term  
 depth of installation  
 water content (on mass basis)  
 water content (on volume basis)

## symbol

$\Phi$   
 $U$   
 $S$   
 $T$   
 $\Delta T$   
 $\tau$   
 $t$   
 $\lambda$   
 $r$   
 $c_{\text{volumetric}}$   
 $R$   
 $S$   
 $x$   
 $Q$   
 $Q_v$

## unit

$W/m^2$   
 $V$   
 $V/(W/m^2)$   
 $^{\circ}C$   
 $^{\circ}C, K$   
 $s$   
 $s$   
 $W/(m \cdot K)$   
 $m \cdot K/W$   
 $J/(m^3 \cdot K)$   
 $\Omega$   
 $W/m^2$   
 $m$   
 $kg/kg$   
 $m^3/m^3$

## subscripts

property of thermopile sensor  
 property obtained under calibration reference conditions  
 property at the (soil) surface  
 property of the surrounding soil  
 property of the heater  
 property obtained by self-test  
 property obtained by self-calibration  
 property of the current-sensing resistor

sensor

reference

surface

soil

heater

selftest

selfcalibration

current

# Introduction

HFP01SC self-calibrating heat flux sensor™ is a heat flux sensor for use in the soil. It offers the best available accuracy and quality assurance of the measurement. The on-line self-test verifies the stable performance and good thermal contact of sensors that are buried and cannot be visually inspected and taken to the laboratory for recalibration. The self-test also includes self-calibration which compensates for measurement errors caused by the thermal conductivity of the surrounding soil (which varies with soil moisture content), for sensor non-stability and for temperature dependence.

The total thermal resistance is kept small by using a ceramics-plastic composite body. Equipped with heavy duty cabling, protective covers at both sides and potted so that moisture does not penetrate the sensor, HFP01SC has proven to be very robust and stable. It survives long-term installation in soils.

HFP01SC measures soil heat flux in  $W/m^2$ . It is used when the highest level of quality assurance and a high measurement accuracy are required. In essence, HFP01SC is a combination of a heat flux sensor and a film heater. The heat flux sensor output is a voltage signal that is proportional heat flux through the sensor. At a regular interval the film heater is activated to perform a self-test. The self-test results in a verification of sensor contact to the soil and in a new sensitivity that is valid for the circumstances at that moment. The latter is called self-calibration. Implicitly also cable connection, data acquisition and data processing are tested. The result is a much improved accuracy & quality assurance of the measurement relative to measurements with conventional sensors such as model **HFP01**.

Soil heat flux sensors are preferably left in the soil for as long as possible, so that the soil properties become representative of the local conditions. Using self-testing, the user no longer needs to take sensors to the laboratory to verify their stable performance. A typical measurement location is equipped with 2 or more sensors for good spatial averaging.

## Unique features and benefits

- low thermal resistance
- large guard area (required by the ISO 9869 standard)
- low electrical resistance (low pickup of electrical noise)
- high sensitivity (good signal to noise ratio in low-flux environments)
- robustness, including a strong cable (essential for permanently installed sensors)
- IP protection class: IP67 (essential for outdoor application)
- incorporated film heater for self-testing

## Suggested use

- high-accuracy scientific measurement of soil heat flux, with a high level of data quality assurance

## Measurement and control

Requirements for data acquisition and control:

- for heat flux: one millivolt measurement
- for heater current: one current measurement (or voltage over a current sensing resistor)
- for switching the heater current on and off: one relay with 12 VDC nominal output

The sensor in HFP01SC is a thermopile. This thermopile measures the temperature difference across the ceramics-plastic composite body of HFP01SC. A thermopile is a passive sensor; it does not require power. HFP01SC can be connected directly to commonly used data logging systems. The heat flux,  $\Phi$ , in  $W/m^2$ , is calculated by dividing the HFP01SC output, a small voltage  $U$ , by the sensitivity  $S_{reference}$ .

The measurement function for HFP01SC is:

$$\Phi = U/S_{reference} \quad (\text{Formula 0.1})$$

The factory-determined sensitivity  $S_{reference}$ , as obtained under calibration reference conditions, is provided with HFP01SC on its product certificate.

HFP01SC calibration is traceable to international standards. The factory calibration method follows the recommended practice of ASTM C1130. The recommended calibration interval of common heat flux sensors is 2 years. With HFP01SC, using the self-test, this may be extended to 5 years.

Every 6 h, the HFP01SC film heater is switched on to perform a self-test. During the self-test the normal heat flux measurement is interrupted.

Analysis of the heat flux sensor response to heating, the self-test, serves two purposes:

- The amplitude and response time are indicators of the quality of contact of the sensor to the soil.
- The signal level during self-testing is used for self-calibration, which results in a new sensitivity  $S_{selfcalibration}$ .

If response time and signal level are within user-determined acceptance limits, from the moment a new sensitivity has been determined the user works with:

$$\Phi = U/S_{selfcalibration} \quad (\text{Formula 0.2})$$

The new sensitivity  $S_{\text{selfcalibration}}$  compensates for:

- the deflection error caused by non-perfect matching of the thermal conductivity of sensor and soil, including changes of the thermal conductivity of the soil caused by changing moisture content.
- temperature dependence of the sensitivity of the heat flux sensor
- non-stability of the heat flux sensor

Additional quality assurance is offered by:

- Monitoring of seasonal and yearly patterns of the sensitivity  $S_{\text{selfcalibration}}$  which quantifies the sensor stability.



Figure 0.1 HFP01SC self-calibrating heat flux sensor. The opposite side has a blue cover.



Figure 0.2 HFP01SC. The opposite side has a red cover. Standard cable length is 5 m (2 cables).

The uncertainty of a measurement with HFP01SC is a function of:

- calibration uncertainty, use of self-calibration.
- differences between reference conditions during calibration and measurement conditions, for example uncertainty caused temperature dependence of the sensitivity.
- the duration of sensor employment (involving the non-stability)
- application errors: the measurement conditions and environment in relation to the sensor properties, the influence of the sensor on the measurand, the representativeness of the measurement location

The user should make his own uncertainty evaluation. Detailed suggestions for experimental design and uncertainty evaluation can be found in the following chapters.

## Calibration

HFP01SC calibration is traceable to international standards. The factory calibration method follows the recommended practice of ASTM C1130.

## Options

- longer cable (both cables), in multiples of 5 m, cable lengths above 20 m in multiples of 10 m

## See also

- in case a less accurate measurement is sufficient, consider model [HFP01](#)
- model [FHF05SC](#) for general purpose, curved surface and research applications up to 120 °C
- view our complete [range of heat flux sensors](#)

# 1 Ordering and checking at delivery

## 1.1 Ordering HFP01SC

The standard configuration of HFP01SC is with 2 x 5 meters cable.

Common options are:

- Longer cable in multiples of 5 m, cable lengths above 20 m in multiples of 10 m.  
Specify total cable length.

## 1.2 Included items

Arriving at the customer, the delivery should include:

- heat flux sensor HFP01SC
- cable of the length as ordered
- product certificate matching the instrument serial number

## 1.3 Quick instrument check

A quick test of the instrument can be done by connecting it to a multimeter.

1. Check the electrical resistance of the sensor between the green [-] and white [+] wires of cable [1]. Use a multimeter at the 100  $\Omega$  range. Measure the sensor resistance first with one polarity, then reverse the polarity. Take the average value. The typical resistance of the wiring is 0.1  $\Omega$ /m. Typical resistance should be the nominal sensor resistance of 2  $\Omega$  for plus 1.5  $\Omega$  for the total resistance of two wires (back and forth) of each 5 m. Infinite resistance indicates a broken circuit; zero or a lower than 1  $\Omega$  resistance indicates a short circuit.
2. Check if the sensor reacts to heat: put the multimeter at its most sensitive range of DC voltage measurement, typically the 100 x 10<sup>-3</sup> VDC range or lower. Expose the sensor heat, for instance touching it with your hand, or activating the HFP01SC heater by putting 9 to 12 VDC across the green and brown wires of cable [2]. The signal should read > 2 x 10<sup>-3</sup> V now. Touching or exposing the red side should generate a positive signal, doing the same at the opposite side the sign of the output reverses.
3. Check the electrical resistance of the film heater between the wires of cable [2]. Use a multimeter at the 1000  $\Omega$  range. Typical resistance should be the typical heater resistance of 100  $\Omega$   $\pm$  15 %. Infinite resistance indicates a broken circuit; zero or a lower than 1  $\Omega$  resistance indicates a short circuit.
4. Inspect the instrument for any damage.
5. Check the sensor serial number, and sensitivity on the cable labels of cable [1] (one at sensor end, one at cable end) against the product certificate provided with the sensor.
6. Check the heater resistance value in  $\Omega$  on the product certificate.

# 2

## Instrument principle and theory

HFP01SC's scientific name is heat flux sensor. A heat flux sensor measures the heat flux density through the sensor itself. This quantity, expressed in  $W/m^2$ , is usually called "heat flux". HFP01SC users typically assume that the measured heat flux is representative of the undisturbed heat flux at the location of the sensor. Users may also apply corrections based on scientific judgement.

HFP01SC has an integrated film heater. At a regular interval the film heater is activated to perform a self-test. The self-test results in a verification of sensor contact to the soil and in a new sensitivity that is valid for the circumstances at that moment. The latter is called self-calibration. Implicitly also cable connection, data acquisition and data processing are tested.

Unique features of HFP01SC are:

- low thermal resistance
- large guard area (required by the ISO 9869 standard)
- low electrical resistance (low pickup of electrical noise)
- high sensitivity (good signal to noise ratio in low-flux environments)
- robustness, including a strong cable (essential for permanently installed sensors)
- IP protection class: IP67 (essential for outdoor application)
- incorporated film heater for self-testing

### 2.1 General heat flux sensor theory

The sensor in HFP01SC is a thermopile. This thermopile measures the temperature difference across the ceramics-plastic composite body of HFP01SC.

Working completely passive, the thermopile generates a small voltage that is a linear function of this temperature difference. The heat flux is proportional to the same temperature difference divided by the effective thermal conductivity of the heat flux sensor body.

Using the heat flux sensor of HFP01SC is easy. For readout the user only needs an accurate voltmeter that works in the millivolt range. To convert the measured voltage,  $U$ , to a heat flux  $\Phi$ , the voltage must be divided by the sensitivity  $S_{\text{reference}}$ , a constant that is supplied with each individual sensor.

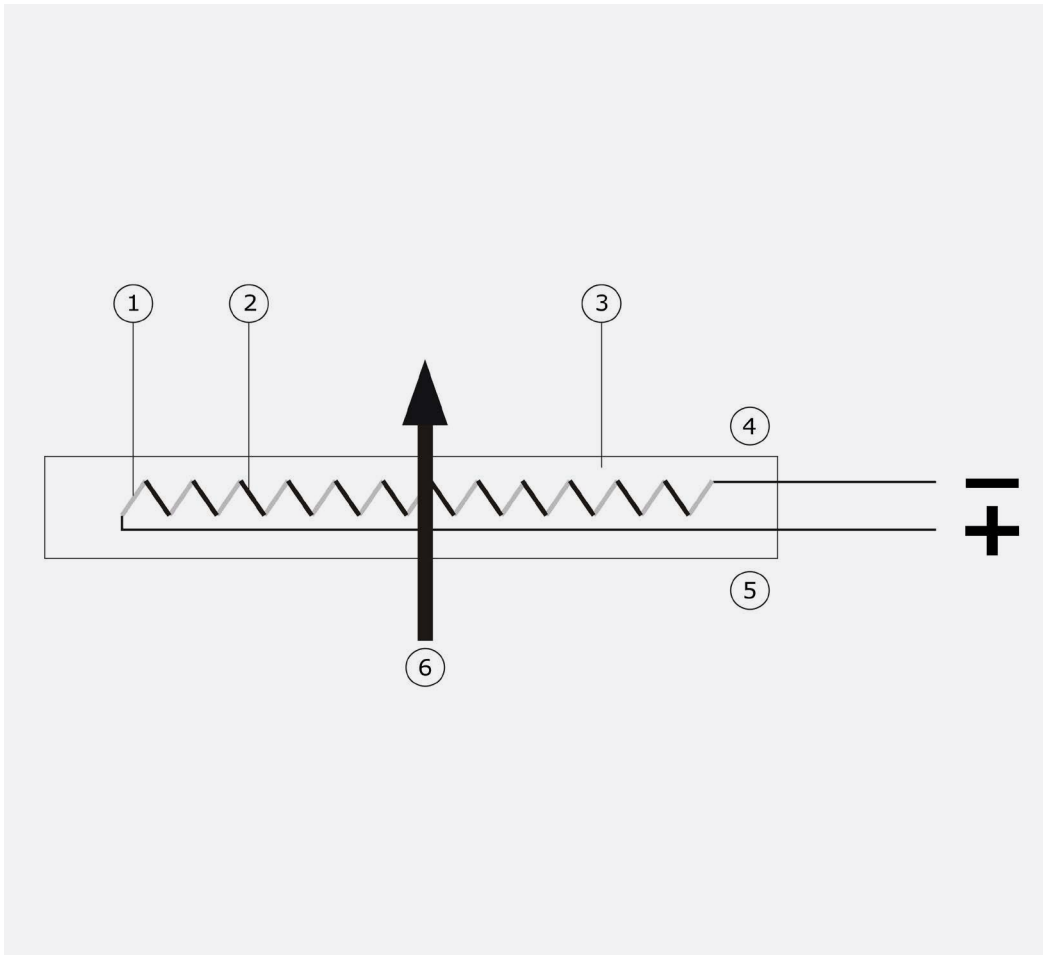

**Figure 2.1** The general working principle of a heat flux sensor. The sensor inside HFP01 is a thermopile. A thermopile consists of a number of thermocouples, each consisting of two metal alloys (marked 1 and 2), electrically connected in series. A single thermocouple generates an output voltage that is proportional to the temperature difference between its hot and cold joints. Putting thermocouples in series amplifies the signal. In a heat flux sensor, the hot and cold joints are located at the opposite sensor surfaces (4 and 5). In steady state, the heat flux (6) is a linear function of the temperature difference across the sensor and the average thermal conductivity of the sensor body (3). The thermopile generates a voltage output proportional to the heat flux through the sensor. The exact sensitivity of the sensor is determined at the manufacturer by calibration, and can be found on the product certificate that is supplied with each sensor.

Heat flux sensors such as HFP01SC, for use in the soil, are typically calibrated under the following reference conditions:

- conductive heat flux (as opposed to radiative or convective)
- homogeneous heat flux across the sensor and guard surface
- room temperature
- heat flux in the order of 350 W/m<sup>2</sup>

Measuring with heat flux sensors, errors may be caused by differences between calibration reference conditions and the conditions during use. The user should analyze his own experiment and make his own uncertainty evaluation. Comments on the most common error sources can be found in the chapter about uncertainty evaluation.

One of the purposes of the self-test, described in the following chapter, is to reduce these errors.

## 2.2 The self-test and self-calibration

A self-test is started by switching on HFP01SC's heater, while recording the sensor output signal and the heater power, and finalized by switching the heater off. During the heating interval a current is fed through the film heater, which generates a known heat flux. To calculate this heat flux the heater current  $I_{\text{heater}}$  must accurately be measured.

For the highest accuracy measurements with the best level of quality assurance, the values  $S_{\text{reference}}$  and  $R_{\text{heater}}$  must be entered individually for every sensor.

The recommended interval between tests is 6 hr. The recommended duration of the test is 360 s. It is divided in a heating interval of 180 s and a settling interval of 180 s. Optionally the interval between tests may be chosen differently, for example 3 or 12 hr.

The user must interrupt the normal measurement of the soil heat flux during the self-test. We recommend that the soil heat flux value of just before the heating interval is copied for at least 360 s. In case of very small soil heat fluxes, this interruption may be 600 s.

Analysis of the heat flux sensor response to the heating, the self-test, serves three purposes:

- First, the amplitude and response time are indicators of the quality of contact of the sensor to the soil. See 2.3.1 for more details.
- Second, the signal level during self-testing is used for self-calibration, which results in a new sensitivity  $S_{\text{selfcalibration}}$  see Figure 4 and Paragraph 2.3.2 for an explanation.
- Third, the functionality of the complete measuring system is verified. For example: a broken cable is immediately detected.

If response time and signal level are within acceptance limits, from the moment a new sensitivity has been determined the user works with:

$$\Phi = U/S_{\text{selfcalibration}} \quad (\text{Formula 2.2.1})$$

The new sensitivity  $S_{\text{selfcalibration}}$  compensates for:

- the deflection error caused by non-perfect matching of the thermal conductivity of sensor and soil, including changes of the thermal conductivity of the soil caused by changing moisture content
- temperature dependence of the sensitivity of the heat flux sensor
- non-stability of the heat flux sensor

Additional quality assurance is offered by:

- Monitoring of seasonal and yearly patterns of the sensitivity  $S_{\text{selfcalibration}}$  which quantifies the sensor stability.

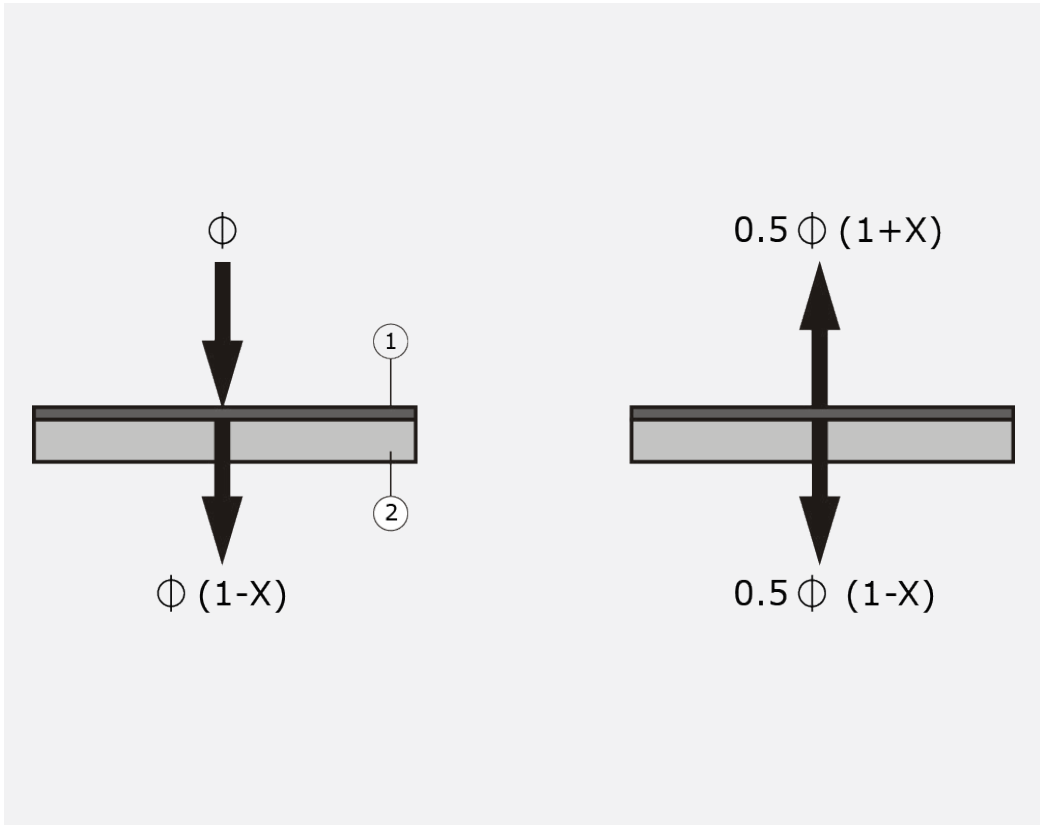

Figure 2.21 Explanation of the self-calibration: on the left, the heat flux sensor (2) measures a soil heat flux  $\Phi$ . This flux is subject to a measurement error  $-X$ , the deflection error which depends on the thermal conductivity of the soil compared to that of the sensor and its thermal contact to the soil. On the right, during the self-test the film heater (1) is switched on to generate a known electrically generated heat flux. As a first approximation, the division of the total heat flux between downward flux through the sensor and upward flux contains the same  $(1-X)$  term that also characterizes the deflection error. The signal level during the self-test, multiplied by 2, is used for self-calibration. The newly measured sensitivity compensates for the deflection error, and also for temperature dependence of the sensitivity and non-stability of the sensor.

### 2.3 Programming the self-test and self-calibration

#### 2.3.1 The self-test

Bad contact to the soil and also malfunctions cable and data acquisition will result in:

- long response times and
- high or low measured sensitivities  $S_{\text{selfcalibration}}$  during self-calibration.

We recommend defining acceptance intervals for these parameters.

For exact definition of the parameters and calculation of  $S_{\text{selfcalibration}}$  see the next paragraph.

We suggest to generate an error message if  $S_{\text{selfcalibration}}$  is larger than the factory determined  $S_{\text{reference}}$  outside a +5 to -20 % acceptance interval around the original  $S_{\text{reference}}$ .

$$0.8 S_{\text{reference}} < S_{\text{selfcalibration}} < 1.05 S_{\text{reference}} \quad (\text{Formula 2.3.1.1})$$

We suggest generating an error message if response times are too long.

$$|U(360) - U(0)| > 0.1 U_{\text{selfcalibration}} \quad (\text{Formula 2.3.1.2})$$

$$|U_{\text{selfcalibration}}(170) - U_{\text{selfcalibration}}(180)| > 0.1 U_{\text{selfcalibration}} \quad (\text{Formula 2.3.1.3})$$

## 2.3.2 Self-calibration

The difference in voltage output,  $U_{\text{selfcalibration}}$ , of the sensor without heating and after heating for 180 s, multiplied by 2 (because only half of the flux passes the sensor) is divided by the heat flux generated by the heater,  $\Phi_{\text{selfcalibration}}$ , to calculate the new sensitivity,  $S_{\text{selfcalibration}}$ .

Typically measurements are taken at 0, 180 and 360 s. The heat flux sensor voltage output at time t is U(t), with t = 0 just before switching on the heater.

$$\Phi_{\text{selfcalibration}} = (U_{\text{current}}^2 \cdot R_{\text{heater}}) / (R_{\text{current}}^2 \cdot A_{\text{heater}}) \quad (\text{Formula 2.3.2.1})$$

$$U_{\text{selfcalibration}} = |U(180) - 0.5 \cdot (U(0) + U(360))| \quad (\text{Formula 2.3.2.2})$$

$$S_{\text{selfcalibration}} = 2 \cdot U_{\text{selfcalibration}} / \Phi_{\text{selfcalibration}} \quad (\text{Formula 2.3.2.3})$$

Concluding:

$$S_{\text{selfcalibration}} = 2 \cdot U_{\text{selfcalibration}} \cdot R_{\text{current}}^2 \cdot A_{\text{heater}} / (U_{\text{current}}^2 \cdot R_{\text{heater}}) \quad (\text{Formula 2.3.2.4})$$

NOTE:  $R_{\text{heater}}$  is a property of the individual sensor. Its nominal value is 100  $\Omega$ . Its exact value can be found on the calibration certificate. For accurate measurements the exact value of  $R_{\text{heater}}$  must be entered into the equation. The value of  $A_{\text{heater}}$  is its nominal value. The value of  $R_{\text{current}}$  is its nominal value, assuming use of a 0.1% resistor.

### Example:

Your HFP01SC product certificate might state:  $A_{\text{heater}} = 38.85 \times 10^{-4} \text{ m}^2$  and  $R_{\text{heater}} = 100 \text{ Ohm}$ . With a typical value for  $R_{\text{current}}$  of 10 Ohm, you get

$$\begin{aligned} S_{\text{selfcalibration}} &= 2 \cdot U_{\text{selfcalibration}} \cdot 10^2 \cdot 38.85 \times 10^{-4} / (U_{\text{current}}^2 \cdot 100) \\ &= 7.77 \times 10^{-3} \cdot U_{\text{selfcalibr}} / U_{\text{current}}^2 \end{aligned}$$

With a 12 VDC power supply, you get a value of  $\Phi_{\text{selfcalibration}}$  of about 306 W/m<sup>2</sup>. Power during heating is 1.3 W, and time averaged power consumption is 0.02 W when the interval between tests is 6 h.

With typical voltage readings of

$$\begin{aligned} U_{\text{selfcalibration}} &= 9 \times 10^{-3} \text{ V} \\ U_{\text{current}} &= 1.09 \text{ V} \end{aligned}$$

The final result is

$$S_{\text{selfcalibration}} = 7.77 \times 10^{-3} \cdot 9 \times 10^{-3} / 1.09^2$$

$$= 58.86 \times 10^{-6} \text{ V/(W/m}^2\text{)}$$

In soils, corrections of up to +5 to -20 % relative to the factory supplied sensitivity can be expected (of which +5 % due to temperature dependence).

### 2.3.3 Program summary

In case the user writes his own software program for controlling the HFP01SC self-test, the program flow in table 2.3.3.1 may be used.

Table 2.3.3.1A summary of a program for control of the self-test.

<b>initialization:</b>	<b>enter sensor and system information</b>	<b>serial number, <math>R_{\text{heater}}</math>, <math>R_{\text{current}}</math>, <math>A_{\text{heater}}</math>, <math>S_{\text{reference}}</math></b>	
every 6 h:	stop measurement of $\Phi$ , copy last measured value during 360 s		
	360 s self-test	measure U	
		180 s heating interval	heater ON
			measure U
			measure $I_{\text{heater}}$
		180 setting interval	heater off
			measure U
	self-test: self-calibration	calculate $S_{\text{selfcalibration}}$	
		store $S_{\text{selfcalibration}}$	
	self-test: quality checks	accept/reject $S_{\text{sc}}$	
		accept/reject response time of U	
		if accepted, then: use self-calibration	$S = S_{\text{selfcalibration}}$
		else	$S = S_{\text{reference}}$
			generate warning
	start measurement of $\Phi$ using new $S_{\text{selfcalibration}}$		

# 3 Specifications of HFP01

## 3.1 Specifications of HFP01SC

HFP01SC measures the heat flux density through the surface of the sensor. This quantity, expressed in  $W/m^2$ , is called heat flux. It is exclusively rated for use in the soil. Working completely passive, using a thermopile sensor, HFP01SC generates a small output voltage proportional to this flux. HFP01SC is equipped with a film heater. The heater may be used to perform an online self-test. Analysis of the self-test results in improved quality assurance and accuracy of the measurement. Part of the self-test is self-calibration, which results in a new sensitivity that is valid under the circumstances of that moment. HFP01SC can only be used in combination with a suitable measurement and control system.

Table 3.1.1 Specifications of HFP01SC (continued on next pages).

HFP01SC specifications	
sensor type	self-calibrating heat flux sensor
sensor type according to ISO 9869	heat flow meter
sensor type according to ASTM	heat flow sensor or heat flux transducer
measurand	heat flux
measurand in SI units	heat flux density in $W/m^2$
online functionality testing	self-test, including self-calibration
measurement range	-2000 to 2000 $W/m^2$
sensitivity range	40 to 80 $\times 10^{-6} V/(W/m^2)$
sensitivity (nominal)	60 $\times 10^{-6} V/(W/m^2)$ (adapted using self-calibration)
directional sensitivity	Heat flux from the red to the blue side generates a positive voltage output signal.
rated operating environment	surrounded by soil
expected voltage output	Application in meteorology: -10 to +20 $\times 10^{-3} V$ turning the sensor from one side to the other will lead to a reversal of the sensor voltage output.

measurement function/required programming	without self-calibration: $\Phi = U/S$ with self-calibration: $\Phi = U/S_{\text{selfcalibration}}$
required programming	self-test, including self-calibration
required readout and control	heat flux sensor: 1 x differential voltage channel or 1 single ended voltage channel, input resistance $> 10^6 \Omega$ heater: 1 x current channel or alternatively 1 voltage channel which acts as a current measurement channel using a current sensing resistor heater: 1 x switchable 12 VDC
rated operating temperature range	-30 to +70 °C
temperature dependence	$< 0.1\%/^{\circ}\text{C}$ (compensated using self-calibration)
thermal conductivity dependence	$7\%/(W/(m\cdot K))$ (order of magnitude only) (compensated using self-calibration)
non-stability	$< 1\%/yr$ (compensated using self-calibration)
sensor diameter including guard	$80 \times 10^{-3} \text{ m}$
sensing area	$8 \times 10^{-4} \text{ m}^2$
sensing area diameter	$32 \times 10^{-3} \text{ m}$
passive guard area	$42 \times 10^{-4} \text{ m}^2$ (a passive guard is required by ISO 9869)
guard width to thickness ratio	5 m/m (as required by ISO 9869 D.3.1)
sensor thickness	$5.6 \times 10^{-3} \text{ m}$ ( $6 \times 10^{-3} \text{ m}$ at cable exit from sensor)
sensor thermal resistance	$81 \times 10^{-4} \text{ K}/(W/m^2)$
sensor thermal conductivity	$0.69 \text{ W}/(m\cdot K)$
response time (95 %)	180 s
sensor resistance range	1 to 4 $\Omega$
required sensor power	zero (passive sensor) (provided that self-calibration is not used)
standard governing use of the instrument	Not applicable
standard cable length (see options)	2 x 5 m
wiring	0.15 m wires and shield at cable ends
cable diameter	$4 \times 10^{-3} \text{ m}$

cable markers	2 x sticker, 1 x at sensor and 1 x cable end, wrapped around the heat flux sensor cable (cable 1). Both stickers show sensitivity and serial number.
IP protection class	IP67
rated operating relative humidity range	0 to 100 %
gross weight including 5 m cable	approx. 0.5 kg
net weight including 5 m cable	approx. 0.5 kg
<b>Film heater</b>	
film heater resistance (nominal)	100 $\Omega$ $\pm$ 10 % (measured value supplied with each sensor in the production report)
film heater rated power supply	9 to 15 VDC
film heater power supply	12 VDC (nominal)
film heater area	0.003885 m <sup>2</sup>
suggested current sensing resistor	10 $\Omega$ $\pm$ 0.1 %, 0.25 W, < 15 ppm/°C
<b>Self-test</b>	
power consumption during heating interval (nominal)	1.5 W
power consumption daily average	0.02 W at 6 hr interval between tests and 180 s heating interval
interval between self-tests	6 hr, optionally 3 or 12 hr
self-test duration	360 s
heating interval duration	180 s
settling interval duration	180 s
<b>Installation and use</b>	
recommended number of sensors	2 per measurement location
orientation	red side up
installation	see recommendations in this user manual
cable extension	See chapter on cable extension or order sensors with longer cable.
<b>Calibration</b>	
calibration traceability	to SI units
product certificate	included (showing calibration result and traceability, as well as film heater resistance and surface area)
factory calibration method	method HFPC01, according to ASTM C1130
online calibration method	self-calibration as part of the self-test

calibration hierarchy	From SI through international standards and through an internal mathematical procedure
factory calibration uncertainty	< 3 % (k = 2) compliant with ISO 9869 requirement < 2 % (k = 1)
recommended recalibration interval	5 years, provided that online calibration is used
factory calibration reference conditions	20 °C, heat flux of 350 W/m <sup>2</sup> , thermal conductivity of the surrounding environment 0.0 W/(m·K)
validity of factory calibration	Based on experience the instrument sensitivity will not change during storage. During use the instrument "non-stability" specification is applicable.
field calibration	Is possible by comparison to a calibration reference sensor. Usually mounted side by side. Preferably reference and field sensor of the same model and brand. Typical duration of test > 24 h.

## Measurement accuracy

uncertainty of the measurement	Statements about the overall measurement uncertainty can only be made on an individual basis. see the chapter on uncertainty evaluation.
--------------------------------	--

## Versions/options

longer cable	in multiples of 5 m, cable lengths above 20 m in multiples of 10 m option code = total cable length
--------------	--

## Accessories

no accessories

## 3.2 Dimensions of HFP01SC

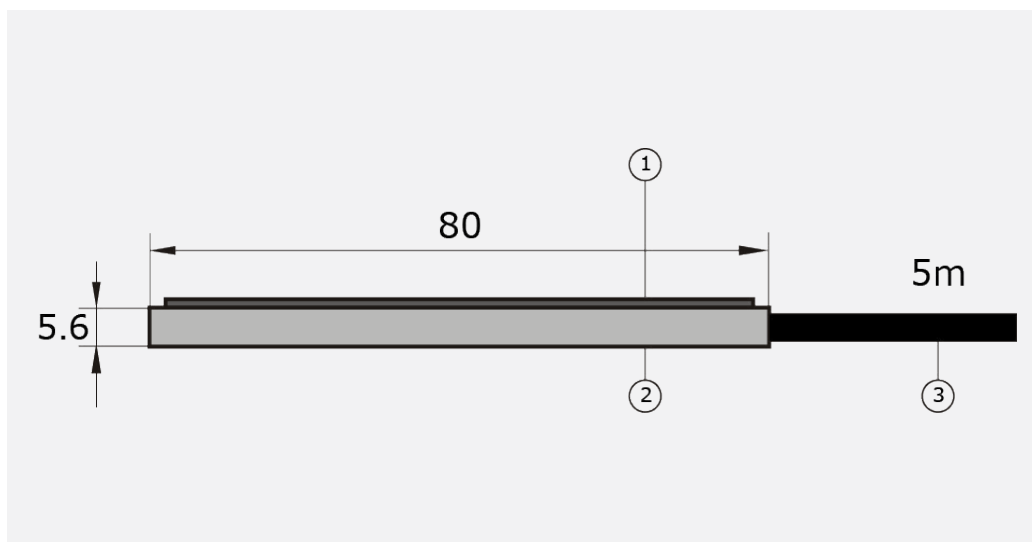

Figure 3.21 HFP01SC heat flux sensor dimensions in  $\times 10^{-3}$  m

1. film heater
2. heat flux sensor plus passive guard
3. 2 x cable (standard length 5 m, optionally longer cable in multiples of 5 m, cable above 20 m in multiples of 10 m)

Total sensor thickness including heater and covers is  $5.6 \times 10^{-3}$  m ( $6 \times 10^{-3}$  m at cable exit from sensor)

# 4 Standards and recommended practices for use

HFP01SC sensors are used to measure heat flux in soils, as part of meteorological surface flux measuring systems. Typically, the total measuring system consists of multiple heat flux and temperature sensors, often combined with measurements of air temperature, humidity, solar or net radiation and wind speed.

In meteorological applications a heat flux sensor measures the energy that flows through the soil, typically at around 0.05 m depth. Usually, this measurement is combined with measurements of the soil temperature to estimate the heat flux at the soil surface. Knowing the heat flux at the soil surface, it is possible to "close the balance" and estimate the uncertainty of the measurement of the other (convective and evaporative) fluxes.

In most meteorological experiments, the main source of energy during daytime is downward solar radiation. The maximum power of the sun is about  $1500 \text{ W/m}^2$ , around noon at low latitudes under clear sky conditions. The solar radiation is either reflected or absorbed by the soil. The absorbed heat is divided between evaporation of water, heating of the ambient air and heating of the soil.

At night, the sun is no longer present, the net irradiance is upward. The soil then loses energy through far infrared radiation to the sky. The maximum upward net irradiance is about  $150 \text{ W/m}^2$ , under clear sky conditions. The heat flux in the soil at 0.05 m depth is usually between  $-100$  and  $+300 \text{ W/m}^2$ .

The measurement of the soil heat flux with HFP01SC using the self-test is more reliable and accurate than without the self-test. However, there still is a large source of uncertainty:

1. Representativeness: measurement at one location has an uncertain validity for the larger area under observation.

When estimating the surface heat flux, there is a second source of uncertainty:

2. Uncertainty of the storage term (not formally part of the HFP01SC measurement).

Ad 1: In field experiments it is difficult to find a single location that is representative of the whole region. On a limited timescale effects of shading of the soil surface can give an unrepresentative measurement. To be less sensitive to such effects, we recommend using two sensors for each station or measurement location, usually at a distance of  $> 5 \text{ m}$ .



Figure 4.2.1 Typical meteorological surface energy balance measurement system with HFP01SC installed under the soil.

Ad 2: For various reasons, practical as well as scientific, the heat flux plate must be installed under the soil, and not directly at the soil surface. First, the self-calibration only works when the sensor is surrounded by soil. Second, mounting at the surface would distort the flow of moisture, and the measured flux would no longer be representative for the flux in the surrounding soil. Third, the absorption of solar radiation would not be representative. Fourth, the sensor would be more vulnerable. The mechanical stability of the installation then becomes an uncertain factor. Heat flux sensors in meteorological applications are typically buried at a depth of about 0.05 m below the soil surface. Installation at a depth of less than 0.05 m is not recommended. In most cases a 0.05 m soil layer on top of the sensor offers just sufficient mechanical stability to guarantee stable measurement conditions. Installation at a depth of more than 0.08 m is not recommended, because at larger depths of installation the time delay and amplitude of the measured heat flux becomes less accurately traceable to momentous flux at the soil surface.

For the above reasons the flux at the soil surface  $\Phi_{\text{surface}}$  is usually estimated from the flux measured by the heat flux sensor plus the change of the energy stored in the layer above the sensor during the measuring interval  $t_1$  to  $t_2$ .

$$\Phi_{\text{surface}} = \Phi_{0.05 \text{ m}} + S \quad (\text{Formula 4.2.1})$$

The quantity S is called the storage term.

The storage term is calculated from a space-averaged soil temperature measurement, using multiple soil temperature sensors, and an estimate of the volumetric heat capacity  $c_{\text{volumetric}}$  of the soil above the sensor.

$$S = (T(t_1) - T(t_2)) \cdot c_{\text{volumetric}} \cdot x / (t_1 - t_2) \quad (\text{Formula 4.2.2})$$

Where  $T(t_1) - T(t_2)$  is the temperature difference in the measurement interval,  $x$  the depth of installation of the soil heat flux sensors.

A correct estimate of  $\Phi_{\text{surface}}$  with a high time resolution requires a low depth of installation and a correct estimate of the storage term.

At an installation depth of 0.05 m, the storage term typically represents up to 50 % of the total  $\Phi_{\text{surface}}$ . When the temperature  $T$  is measured closely below the surface, the response time of the storage term to a changing  $\Phi_{\text{surface}}$  is in the order of magnitude of 20 min, while the heat flux sensor buried at twice the depth is a factor 5 slower (square of the depth). The volumetric heat capacity is estimated from the specific heat capacity of dry soil,  $c_{\text{soil, dry}}$ , the bulk density of the dry soil  $\rho$ , the water content on mass basis  $Q$ , on a volume basis  $Q_v$ , and  $c_{\text{water}}$ , the specific heat capacity of water.

$$\begin{aligned} c_{\text{volumetric}} &= \rho_{\text{soil}} \cdot (c_{\text{soil, dry}} + Q \cdot c_{\text{water}}) \\ &= \rho_{\text{soil}} \cdot c_{\text{soil, dry}} + \rho_{\text{water}} \cdot Q_v \cdot c_{\text{water}} \end{aligned} \quad (\text{Formula 4.2.3})$$

The heat capacity of water is known, but the other quantities of the equation are difficult to determine and vary with location and time. The storage term may be the main source of uncertainty in the soil energy balance measurement.

A typical value for dry soil heat capacity is 840 J/(kg·K)

# 5 Installation of HFP01SC

## 5.1 Site selection and installation

Table 5.1.1 Recommendations for installation of HFP01SC (continued on next page).

location	<p>Preferably install in a large field which is relatively homogeneous and representative of the area under observation.</p>
orientation	<p>Recommended orientation is with the red side of the sensor facing upwards. This generates a positive output signal when the heat flux is downward and also of the heat flux generated by the heater.</p> <p>Reversing the sensor orientation will result in a change of sign of the voltage output of the ambient heat flux (not of the flux generated by the heater). If necessary, this may be compensated by reversing the wiring at the data logger connection, or in the post processing for example by giving the sensitivity a negative sign.</p> <p>The self-test will work independent of orientation.</p>
performing a representative measurement	<p>We recommend using &gt; 2 sensors per location at a distance of &gt; 5 m. This redundancy also improves the assessment of The measurement accuracy.</p>
installation	<p>Depth of installation typically is 0.05 m.</p> <p>If possible, install the sensor from the side of a small hole. There should be no air gaps between sensor and soil. A <math>0.1 \times 10^{-3}</math> m air gap increases the effective thermal resistance of the sensor by 60 %.</p> <p>Use a shovel to make a vertical slice in the soil. Make a hole in the soil at one side of the slice. Keep the excavated soil intact so that after installing the sensor the original soil structure can be restored. The sensor is installed in the undisturbed face of the excavated hole. Measure the depth from the soil surface at the top of the hole. With a knife, make a horizontal cut at the required depth of installation, for example at 0.05 m below the surface, into the undisturbed face of the hole. Insert the heat flux sensor into the horizontal cut.</p> <p>Never run the sensor cable directly to the surface. Bury the sensor cable horizontally over a distance of at least 1 m, to minimize thermal conduction through the lead wire. Put the excavated soil back into its original position after the sensor and cable are installed.</p>

fixation/strain relief	For mechanical stability, provide sensor cables with an additional strain relief, for example connecting the cable with a tie wrap to a metal pin that is inserted firmly into the soil.
armored cable	In some cases cables are equipped with additional armor to avoid damage by rodents. Make sure the armor does not act as a conductor of heat or a transport conduit or container of water.
added temperature sensors	Temperature sensors are typically located close to the heat flux sensor at 2 depths above it: when the sensor is buried at 0.05 m, temperature sensors may be buried at 0.02 and 0.04 m below the soil surface.

## 5.2 Electrical connection

HFP01SC has two separate cables, one for the signal, cable 1, and one for the heater, cable 2.

An HFP01SC should be connected to a measurement and control system, typically a so-called data logger. HFP01SC's heat flux sensor is a passive sensor that does not need any power. The heater is powered from 12 VDC, using a relay to switch it on and off.

Cables may act as a source of distortion, by picking up capacitive noise.

We recommend keeping the distance between a data logger or amplifier and the sensor as short as possible. For cable extension, see the appendix on this subject.

The heat flux sensor output is connected to a differential or single-ended voltage input. The voltage across the current sensing resistor is measured by a differential voltage channel.

**Table 5.2.1** Connections of cable 1 heat flux sensor signal. Cable 1 internally also has a brown wire, which is not used and not visible when supplied from the factory. The wires extend 0.15 m from the cable end.

	wire		measurement system
1	white	signal [+]	voltage input [+]
1	green	signal [-]	voltage input [-] or ground
1	black	ground	analogue ground

**Table 5.2.2** Connections of cable 2 heater connection. Cable 2 internally also has a white wire, which is not used and not visible when supplied from the factory. The wires extend 0.15 m from the cable end.

	wire		measurement system
2	green	heater (brown and green wires are equivalent)	12 VDC power supply, possibly to a current sensing resistor
2	brown	heater (brown and green wires are equivalent)	12 VDC power supply, possibly to a current sensing resistor
2	black	ground	analogue ground

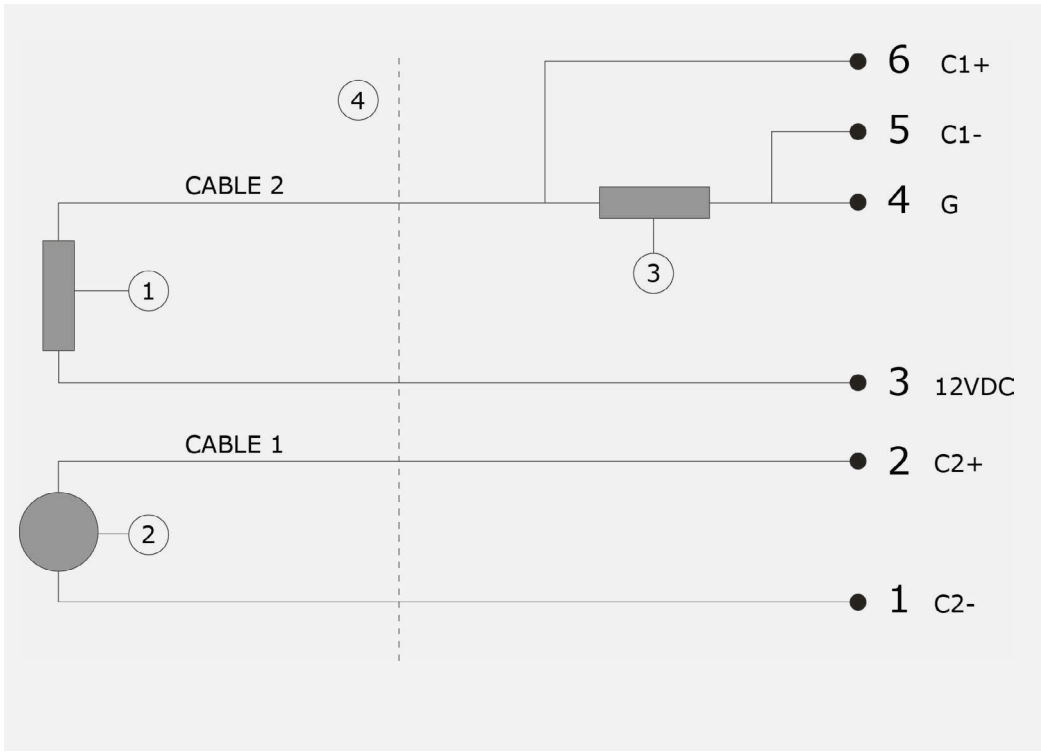

**Figure 5.2.1** electrical connection HFP01SC. Dashed line (4) separates between the HFP01SC on the left and the cable and the data logger on the right. Heat flux sensor (2) wires are connected to data logger inputs 1 and 2. Film heater (1) heater wires are connected to the power supply at 3 and 4. The heater current is usually measured using a 10 Ω current sensing resistor (not included with HFP01SC) (3) in series with the heater, and by measuring the voltage across the resistor, at data logger inputs 5 and 6.

**NOTE:** the current sensing resistor is not part of the delivery.

### 5.3 Requirements for data acquisition/amplification

The selection and programming of data loggers is the responsibility of the user. To see if directions for use with HFP01SC are available: contact the supplier of the data acquisition equipment.

Table 5.3.1 Requirements for data acquisition, amplification and control equipment for HFP01SC in the standard configuration.

capability to measure small voltage signals	preferably: $5 \times 10^{-6}$ V uncertainty minimum requirement: $20 \times 10^{-6}$ V uncertainty (valid for the entire expected temperature range of the acquisition/amplification equipment)
capability to measure the heater current	The heater is powered from 12 VDC, at 0.12 A. The current should be measured with an uncertainty of < 1% A $10 \Omega \pm 0.1\%$ current sensor resistor is often used.
capability to switch the heater on and off	A relay must be used, capable of switching the required 12 VDC at 0.12 A (nominal values).
capability for the data logger or the software	To store data, and to perform division by the sensitivity to calculate the heat flux. $\Phi = U/S$ (Equation 0.1) To time and control the self-test. To perform comparison of test results against the acceptance limits. To reset the sensitivity S to $S_{sc}$ .
data acquisition input resistance for heat flux sensor	$> 1 \times 10^6 \Omega$
open circuit detection (WARNING)	Open-circuit detection should not be used, unless this is done separately from the normal measurement by more than 5 times the sensor response time and with a small current only. Thermopile sensors are sensitive to the current that is used during open circuit detection. The current will generate heat, which is measured and will appear as a temporary offset.

# 6

## Making a dependable measurement

### 6.1 Uncertainty evaluation

A measurement with a heat flux sensor is called “dependable” if it is reliable, i.e. measuring within required uncertainty limits, for most of the time and if problems, once they occur, can be solved quickly.

In case of heat flux sensors, the measurement uncertainty is a function of:

- calibration uncertainty
- differences between reference conditions during calibration and measurement conditions, for example uncertainty caused by temperature dependence of the sensitivity
- the duration of sensor employment (involving the non-stability)
- application errors: the measurement conditions and environment in relation to the sensor properties, the influence of the sensor on the measurand, the representativeness of the measurement location
- corrections applied for example using self-calibration

It is not possible to give one figure for heat flux sensor measurement uncertainty. Statements about the overall measurement uncertainty can only be made on an individual basis, taking all these factors into account.

When measuring in soils, we recommend using model HFP01SC to get a higher level of quality assurance and accuracy of the measurement. HFP01SC's self-test partially compensates for the temperature dependence, non-stability and the deflection error.

Guidelines for uncertainty evaluation:

1. The formal evaluation of uncertainty should be performed in accordance with ISO 98-3 *Guide to the Expression of Uncertainty in Measurement*, GUM.
2. Uncertainties are entered in measurement equation (equation is usually Formula 0.1:  $E = U/S$ ), either as an uncertainty in E (non-representativeness, resistance error and deflection error) in U (voltage readout errors) or in S (non-stability, temperature dependence, calibration uncertainty).
3. In case of special measurement conditions, typical specification values are chosen. These should for instance account for environmental conditions (working temperature range).
4. Among the various sources of uncertainty, some are “correlated”; i.e. present during the entire measurement process, and not cancelling or converging to zero when averaged over time; the off-diagonal elements of the covariance matrix are not zero. Paragraph 5.2 of GUM.
5. Among the various sources of uncertainty, some are “uncorrelated”; cancelling or converging to zero when averaged over time; the off-diagonal elements of the covariance matrix are zero. Paragraph 5.1 of GUM.

## 6.2 Typical measurement uncertainty budget

Table 6.2.1 Typical measurement uncertainties (k = 2) when measuring heat flux with HFP01SC heat flux sensors.

application	typical measurement uncertainty budget (k = 2)
meteorology	<p>measurements of heat flux in the soil, using the factory sensitivity <math>S_{\text{reference}}</math> only, may attain uncertainties in the <math>\pm 20\%</math> range.</p> <p>The self-calibration partially compensates for the deflection error, non-stability and temperature dependence, ideally attaining uncertainties in the <math>\pm 10\%</math> range. The uncertainty evaluation then assumes that the self-check including the self-calibration reduces usual uncertainties related to non-stability, temperature dependence and deflection by 50 %.</p> <p>In case the heater resistance is not entered as an individual value per sensor, the electrical power measurement contains a resistance with an uncertainty of <math>\pm 10\%</math>. The total uncertainty then is of the order of <math>\pm 15\%</math>.</p> <p>Further contributions to the uncertainty budget: representativeness of the measurement location.</p> <p>Not included: estimates of the storage term, which is not part of the HFP01SC measurement.</p>

## 6.3 Contributions to the uncertainty budget

When measuring in soils, we recommend using model HFP01SC to get a higher level of quality assurance and accuracy of the measurement. HFP01SC's self-calibration compensates for the temperature dependence, non-stability and the deflection error. We usually assume that the self-check including the self-calibration reduces usual uncertainties related to non-stability, temperature dependence and deflection by 50 %.

### 6.3.1 Calibration uncertainty

HFP01SC's factory calibration uncertainty under reference conditions is  $\pm 3\%$  with a coverage factor  $k = 2$ .

### 6.3.2 Uncertainty caused by non-stability

HFP01SC's non-stability specification is  $< 1\%/yr$ . This means that for every year of operation, 1% uncertainty should be added in the uncertainty budget, unless the self-calibration is used. We usually assume that the self-check including the self-calibration reduces usual uncertainties related to non-stability, by 50 %.

### 6.3.3 Uncertainty caused by— and correction of—the deflection error

The thermal conductivity of the surrounding environment may differ from the sensor thermal conductivity. The heat flux will then deflect. The resulting measurement error is called the deflection error. The deflection error may be estimated by experiments or by numerical simulation.

Corrections may be applied according to chapter 8 of ISO 9869. These corrections include corrections for the finite dimension of the sensor. ISO also calls this the operational error, we use the term deflection error.

As Figure 6.3.4.1 illustrates, the deflection error is largest at the sensor edges, and smaller at the center. For this reason sensors are equipped with a passive guard around the sensitive sensor area.

For sensors that are fully surrounded by a uniform homogeneous material which have a perfect thermal connection, the deflection error may be expressed as thermal conductivity dependence  $D_\lambda$  of the sensitivity  $S$ . The order of magnitude of  $D_\lambda$  is constant for one sensor model.  $D_\lambda$  used to be part of the HFP01SC product specifications. The order of magnitude of  $D_\lambda$  is  $7\%/ (W/(m\cdot K))$ . The value of  $\lambda_{ref}$  is  $0.0 W/(m\cdot K)$ .

$$S = S_{reference} \cdot (1 + D_\lambda \cdot (\lambda_{environment} - \lambda_{reference})) \quad (\text{Formula 6.3.4.1})$$

A correction may be applied when there is a substantial amount (at least  $40 \times 10^{-3} m$ ) of the same material at both sides of the sensor.

In soils  $\lambda_{environment}$  usually is not known.

When measuring in soils, we recommend using model HFP01SC to get a higher level of quality assurance and accuracy of the measurement. We usually assume that the self-check including the self-calibration reduces usual uncertainties related to deflection by 50 %.

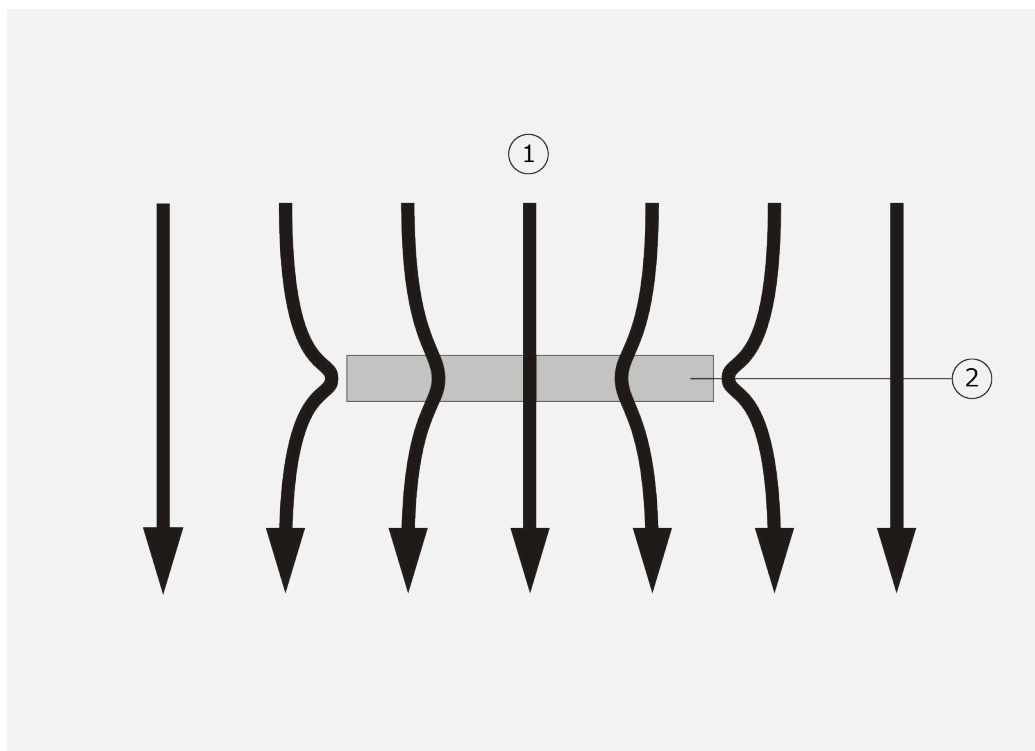

Figure 6.3.3.1 The deflection error. The heat flux (1) is deflected in particular at the edges of the sensor. The measurement will contain an error; the so-called deflection error. The magnitude of this error depends on the thermal conductivity of the environment, sensor thermal conductivity as well as sensor design and contact resistance.

### 6.3.4 uncertainty caused by temperature dependence

HFP01SC's temperature dependence specification is  $< 0.1\%/^{\circ}\text{C}$ .

This means that for every  $^{\circ}\text{C}$  deviation from the  $20^{\circ}\text{C}$  reference temperature,  $0.1\%$  uncertainty should be added in the uncertainty budget, unless the self-calibration is used. We usually assume that the self-check including the self-calibration reduces usual uncertainties related temperature dependence by  $50\%$ .

### 6.3.5 Uncertainty caused by the heater resistance

$R_{\text{heater}}$  is a property of the individual sensor. Its nominal value is  $100\ \Omega$ .

Its exact value can be found on the calibration certificate. For accurate measurements the exact value of  $R_{\text{heater}}$  must be entered into the equation. In case the nominal value is used, the  $10\%$  uncertainty should be used. In case the individual value is used, we may work with  $1\%$ .

# 7 Maintenance and trouble shooting

## 7.1 Recommended maintenance and quality assurance

HFP01SC measures reliably at a low level of maintenance. Unreliable measurement results are detected by scientific judgement, for example by looking for unreasonably large or small measured values of heat flux, response time during the self-test and sensitivity measured during the self-test. The preferred way to obtain a reliable measurement is a regular critical review of the measured data, preferably checking against other measurements.

Table 7.1.1 Recommended maintenance of HFP01SC. If possible the data analysis should be done on a daily basis.

Minimum recommended heat flux sensor maintenance			
	interval	subject	action
1	1 day	self-test	at least one self-test per day
2	1 week	data analysis	Compare measured data to the maximum possible or maximum expected heat flux and to other measurements for example from nearby stations or redundant instruments. Historical seasonal records can be used as a source for expected values. Look for any patterns and events that deviate from what is normal or expected. Analyze the self-test measurement results. Compare to acceptance intervals. Plot heat flux data against other meteorological measurands, in particular net radiation and soil temperature.
3	6 months	inspection	Inspect cable quality, inspect mounting, inspect location of installation. Look for seasonal patterns in measurement data and results of the self-test.
4	2 years	lifetime assessment	Judge if the instrument will be reliable for another 2 years, or if it should be replaced.
5	5 years	recalibration	recalibration by the sensor manufacturer

## 7.2 Trouble shooting

Table 7.2.1 Trouble shooting for HFP01SC sensors. (continued on the next page).

general	<p>Inspect the quality of mounting/installation.</p> <p>Inspect if the wires are properly attached to the data logger.</p> <p>Check the condition of the cable.</p> <p>Inspect the connection of the shield (typically connected at the data logger side).</p> <p>Check the data logger program in particular if the right sensitivity is entered. HFP01SC sensitivity and serial number are marked on its cable.</p> <p>Check the electrical resistance of the sensor between the green [-] and white [+] wires of cable [1]. Use a multimeter at the 100 <math>\Omega</math> range. Measure the sensor resistance first with one polarity, then reverse the polarity. Take the average value. The typical resistance of the wiring is 0.1 <math>\Omega</math>/m. Typical resistance should be the nominal sensor resistance of 2 <math>\Omega</math> for plus 1.5 <math>\Omega</math> for the total resistance of two wires (back and forth) of each 5 m. Infinite resistance indicates a broken circuit; zero or a lower than 1 <math>\Omega</math> resistance indicates a short circuit.</p> <p>Check the electrical resistance of the film heater between the wires of cable [2]. Use a multimeter at the 1000 <math>\Omega</math> range. Typical resistance should be the typical heater resistance of 100 <math>\Omega \pm 15\%</math>. Infinite resistance indicates a broken circuit; zero or a lower than 1 <math>\Omega</math> resistance indicates a short circuit.</p> <p>Check the sensor serial number, and sensitivity on the cable labels of cable [1] (one at sensor end, one at cable end) against the product certificate provided with the sensor.</p> <p>Check the heater resistance value in <math>\Omega</math> on the product certificate.</p>
The sensor does not give any signal.	<p>Check if the sensor reacts to heat flux: expose the sensor to a strong heat source; for example a high power lamp. The signal should read <math>&gt; 100 \text{ W/m}^2</math> now. Check the data acquisition by replacing the sensor with a spare sensor.</p> <p>Check if the sensor reacts to heat: put the multimeter at its most sensitive range of DC voltage measurement, typically the <math>100 \times 10^{-3} \text{ VDC}</math> range or lower. Expose the sensor heat, for instance touching it with your hand, or activating the HFP01SC heater by putting 9 to 12 VDC across the green and brown wires of cable [2]. The signal should read <math>&gt; 2 \times 10^{-3} \text{ V}</math> now. Touching or exposing the red side should generate a positive signal, doing the same at the opposite side the sign of the output reverses.</p>
The sensor signal is unrealistically high or low.	<p>Check the cable condition looking for cable breaks.</p> <p>Check the data acquisition by applying a <math>1 \times 10^{-6} \text{ V}</math> source to it in the <math>1 \times 10^{-6} \text{ V}</math> range. Look at the measurement result. Check if it is as expected.</p> <p>Check the data acquisition by short circuiting the data acquisition input with a 10 <math>\Omega</math> resistor. Look at the output. Check if the output is close to 0 <math>\text{W/m}^2</math>.</p>
The sensor signal shows unexpected variations.	<p>Check the presence of strong sources of electromagnetic radiation (radar, radio).</p> <p>Check the condition and connection of the shield.</p> <p>Check the condition of the sensor cable.</p> <p>Check if the cable is not moving during the measurement.</p>

## 7.3 Calibration and checks in the field

Recalibration of field heat flux sensors is ideally done by the sensor manufacturer.

The recommended calibration interval of heat flux sensors is 2 years.

Using the self-calibration this may be reduced to 5 years.

Besides using the self-test which includes self-calibration, field calibration is also possible by comparison to a calibration reference sensor. Usually mounted side by side.

Hukx main recommendations for field calibrations relative to a reference sensor are:

1. To compare to a calibration reference of the same brand and type as the field sensor.
2. To connect both to the same electronics, so that electronics errors (also offsets) are eliminated.
3. To mount all sensors on the same platform, so that they have the same body temperature.
4. Typical duration of test > 24 h.
5. Typical heat fluxes used for comparison: > 20 W/m<sup>2</sup>.
6. To correct deviations of more than  $\pm 10\%$ . Lower deviations should be interpreted as acceptable and should not lead to a revised sensitivity.

# 8 Appendices

## 8.1 Appendix on cable extension/replacement

HFP01SC is equipped with two cables. Keep the distance between data logger or amplifier and sensor as short as possible. Cables may act as a source of distortion by picking up capacitive noise. In an electrically "quiet" environment the HFP01SC cables may be extended without problem to 100 meters. If done properly, the sensor signal, although small, will not significantly degrade because the sensor resistance is very low (which results in good immunity to external sources) and because there is no current flowing (so no resistive losses). Cable and connection specifications are summarized below.

Table 8.1.1 Preferred specifications for cable extension of HFP01SC. Please note that the sensor has two separate cables.

cable	2-wire, shielded, with copper conductor (at Hukx 3-wire shielded cable is used, of which only 2 wires are used)
extension sealing	Make sure any connections are sealed against humidity ingress.
conductor resistance	< 0.1 $\Omega$ /m
outer diameter	4 x 10 <sup>-3</sup> m
length	Cables and wires should be kept as short as possible, in any case, the total cable length should be less than 100 m.
outer mantle	With specifications for outdoor use (for good stability in outdoor applications).
connection	Either solder the new cable conductors and shield to those of the original sensor cable, and make a waterproof connection using heat-shrink tubing with hot-melt adhesive, or use gold plated waterproof connectors. Always connect the shield.

## 8.2 Appendix on standards for calibration

The standard ASTM C1130 Standard Practice for Calibrating Thin Heat Flux Transducers specifies in Chapter 6 that a guarded hot plate, a heat flowmeter, a hot box or a thin heater apparatus are all allowed. Hukx employs a thin heater apparatus, uses a linear function according to X1.1 and uses a nominal temperature of 20 °C, in accordance with X2.2.

The Hukx HFPC01 method relies on a thin heater apparatus according to principles as described in Paragraph 4 of ASTM C1114-06, used in the single sided mode of operation described in Paragraph 8.2 and in ASTM C1044.

ISO does not have a dedicated standard practice for heat flux sensor calibration. ISO 9869 Paragraph 5.1 recommends calibration according to ISO 8302 (guarded hot plate) or ISO 8301 (heat flow meter apparatus) with a  $\pm 2\%$  accuracy. We assume that this statement is with a coverage factor  $k = 1$ . For a known model, Paragraph 5.1.2 allows one heat flow, a typical temperature during use and on a typical building material. ISO 9869 does not describe the calibration apparatus of method. We follow the recommended practice of ASTM C1130.

Table 9.2.1 Heat flux sensor calibration according to ISO and ASTM.

ISO standard	Equivalent ASTM standard
No dedicated heat flux calibration standard available. ISO 9869 recommends use of a guarded hot plate for characterization.	<i>ASTM C1130 Standard Practice for Calibrating Thin Heat Flux Transducers</i>  <i>ASTM C 1114-06 Standard Test Method for Steady-State Thermal Transmission Properties by Means of the Thin-Heater Apparatus</i>  <i>ASTM C1044-12 Standard Practice for Using a Guarded-Hot-Plate Apparatus or Thin-Heater Apparatus in the Single-Sided Mode</i>

## 8.3 Appendix on calibration hierarchy

HFP01SC factory calibration is traceable from SI through international standards and through an internal mathematical procedure which corrects for known errors. The formal traceability of the generated heat flux is through voltage and current to electrical power and electric power and through length to surface area.

The Hukx HFPC01 method follows the recommended practice of ASTM C1130. It relies on a thin heater apparatus according to principles as described in Paragraph 4 of ASTM C1114-06, in the single sided mode of operation described in Paragraph 8.2 and in ASTM C1044. In accordance with ISO 9869, the method has been validated in a first-party conformity assessment, by comparison to calibrations in a guarded hot plate.

## 8.4 Electrical connection of HFP01SC supplied by Campbell Scientific USA

Sensors supplied by Campbell Scientific USA have a different wiring diagram.

The 10  $\Omega$  current sensing resistor is included in the sensor cabling using heat-shrink tubing with hot-melt adhesive.

**Table 8.4.1** FOR SENSORS SUPPLIED BY CAMPBELL USA ONLY: connections of cable 1 heat flux sensor signal. Cable 1 internally also has a brown wire, which is not used and not visible when supplied from the factory. The wires extend 0.15 m from the cable end.

	wire		measurement system
1	black	shield/ground	analogue ground
1	white	sensor signal [+]	voltage input [+]
1	green	sensor signal [-]	voltage input [-] or ground

**Table 8.4.2** FOR SENSORS SUPPLIED BY CAMPBELL USA ONLY connections of cable 2 heater connection. Cable 2 internally also has a white wire, which is not used and not visible when supplied from the factory. The 10  $\Omega$  current sensing resistor is included in the sensor cabling using heat-shrink tubing with hot-melt adhesive. The wires extend 0.15 m from the cable end.

	wire		measurement system
2	clear	shield/ground	analogue ground
2	purple	heater low signal	voltage input [-] (single ended analogue ground)
2	yellow	heater high signal	voltage input [+] (single ended [+] or [-])
2	red	heater power [+]	+ 12 VDC power supply
2	black	heater power [-]	system ground

The 10  $\Omega$  current sensing resistor is included in the sensor cabling using heat-shrink tubing with hot-melt adhesive.

## 8.5 EU declaration of conformity

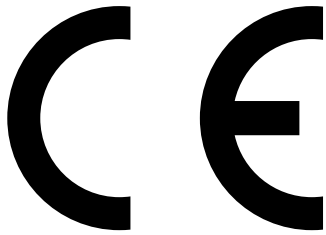

We, Hukseflux Thermal Sensors B.V.,  
Delftechpark 31, 2628 XI, Delft,  
The Netherlands

in accordance with the requirements of the following directive:

2014/30/EU The Electromagnetic Compatibility Directive

hereby declare under our sole responsibility that:

Product models	HFP01SC
Product type	Self-calibrating heat flux sensor
Brand name	Hukx

has been designed to comply and is in conformity with the relevant sections and applicable requirements of the following standards:

Emission	EN 61326-1(2006)
Immunity	EN 61326-1(2006)
Emission	EN 61000-3-2 (2006)
Emission	EN 61000-3-3 (1995) + A1 (2001) + A2 (2005)
Report	08C01340RPT01, 06 January 2009

Eric HOEKSEMA  
Director  
Delft, 08 September 2015

## About Hukx

Hukx is the leading innovator in solar radiation and heat flux sensor technology. We are proud to set the standard in high-accuracy measurement, and to be working at the heart of the energy transition.

Customers worldwide rely on our bestselling pyranometers and heat flux sensors. From sensor design and selection to supply and recalibration, we support you across the entire lifecycle.

Hukx is headquartered in the Netherlands, with locally owned representative sales offices in the USA, Brazil, India, China, Southeast Asia, and Japan.

Let us help you select the best sensor for your application. Get in touch with our experts today via: [info@hukx.com](mailto:info@hukx.com)

© Hukx

Version 2527

We reserve the right to change specifications without prior notice.

[www.hukx.com](http://www.hukx.com)

**HUKX**