

HUKX

Sensor
Technology

User manual
Gardon gauge water-cooled
high heat flux sensor

GG01

Warning statements



Putting more than 12 Volt across the sensor wiring can lead to permanent damage to the sensor.



Do not use "open circuit detection" when measuring the sensor output.



Using a sensor without water cooling may lead to permanent damage to the sensor.



When following standard operating practices, users should purchase their own copies of the standard. This manual offers general guidelines for use only.



Hukseflux performs traceable calibrations and is certified according to ISO 9001, but is not an ISO 17025 accredited calibration laboratory.

Contents

Introduction	5
1 Ordering and checking at delivery	10
1.1 Ordering GG01	10
1.2 Included items	11
1.3 Quick instrument check	11
2 Instrument principle and theory	12
2.1 Gardon gauge technology	13
2.2 Detailed measurement equation	13
2.3 Optional sapphire window	14
3 Specifications	16
3.1 GG01 specifications	16
3.2 Dimensions of GG01	22
3.3 Dimensions of GG01-SW	23
4 Standards and recommended practices for use	24
4.1 Heat flux measurement in fire testing: ISO 14934	24
5 Installation	26
5.2 Electrical connection	27
5.3 Requirements for data acquisition/amplification	27
5.4 Cooling	28
5.5 Uncooled sensors	29
6 Making a dependable measurement	30
6.1 Uncertainty evaluation	30
6.2 Contributions to the uncertainty budget	31
7 Maintenance and trouble shooting	32
7.1 Recommended maintenance and quality assurance	32
7.2 Trouble shooting	33
7.3 Recoating/repainting of sensor surfaces	34
8 Appendices	35
8.1 Appendix on cable extension/replacement	35
8.2 Appendix on calibration hierarchy	36
8.3 Appendix on typical heat flux ranges	36
8.4 Appendix on sensor design: Gardon versus Schmidt-Boelter	38
8.5 EU declaration of conformity	39

List of symbols

quantities	symbol	unit
heat flux	Φ	W/m ²
voltage output	U	V
sensitivity	S	V/(W/m ²)
temperature	T	°C

subscripts

N/A

Introduction

GG01 is a water-cooled sensor that measures extremely high heat fluxes, up to $1000 \times 10^3 \text{ W/m}^2$. Made from high thermal conductivity copper and copper alloys, this modern all-metal sensor keeps working at heat flux levels where other sensors get toasted. An optional sapphire window allows measurement of radiative heat flux only, excluding the convective heat flux. GG01 features an on-board Type K thermocouple and is available with various dedicated measurement ranges. For lower flux ranges, see our **SBG01**.

GG01 is a modern Gardon gauge sensor that measures heat flux in the range of $(250 \text{ to } 1000) \times 10^3 \text{ W/m}^2$. Equipped with a black absorber and water-cooled, the sensor is designed to measure heat flux from strong radiative sources.

Using an open detector, GG01 is also sensitive to convective heat flux—a contribution that is often overlooked.

The GG01 Gardon gauge sensor generates an output voltage proportional to the incoming heat flux. A Type K thermocouple measures the body temperature. The sensor is cooled, usually via tap water, which keeps the sensor body relatively cool despite temperatures of the surrounding air and the radiant source reaching $1000 \text{ }^\circ\text{C}$ and higher.

Figure 01 GG01 Gardon gauge water-cooled high heat flux sensor.

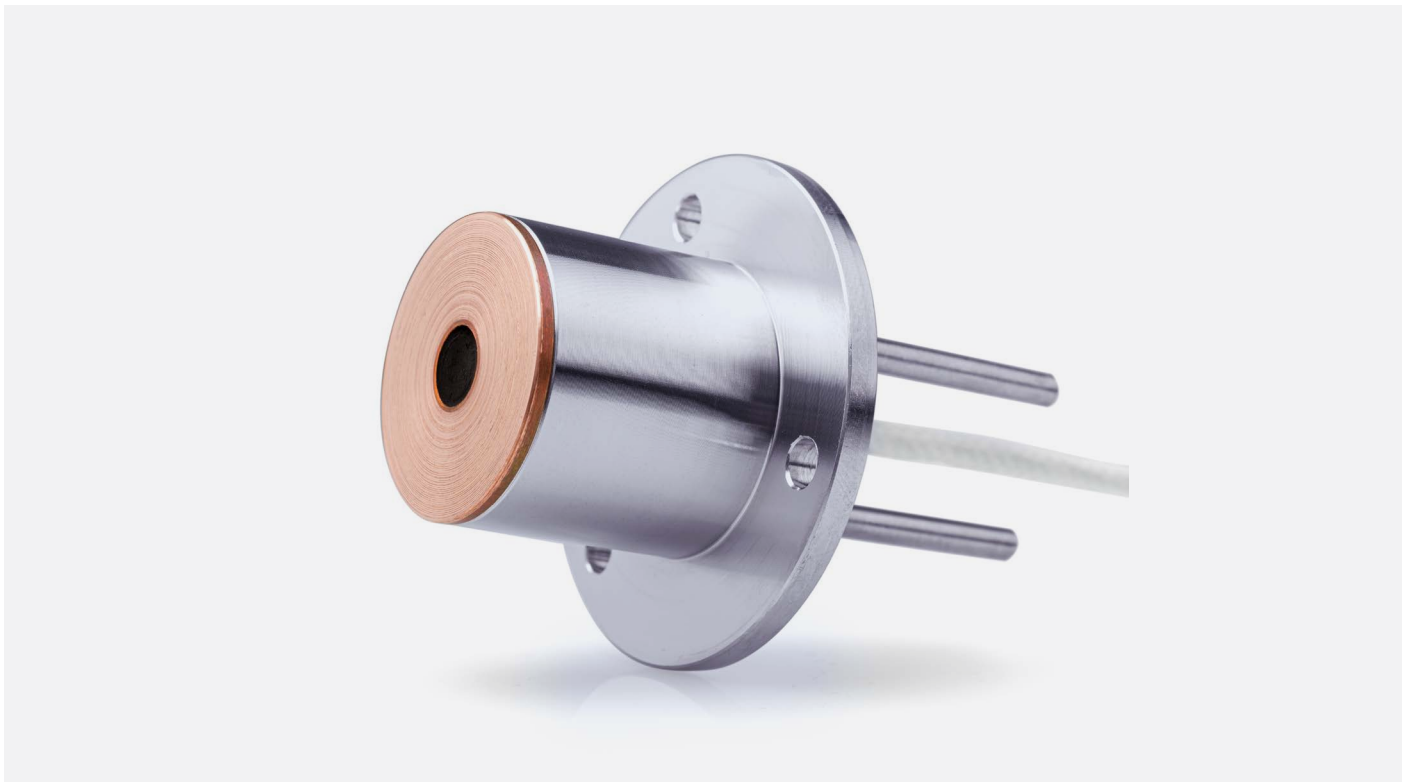

Using GG01 is easy. It can be connected directly to commonly used data logging systems. The heat flux, Φ , in W/m^2 , is calculated by dividing the GG01 output, a small voltage U , by the sensitivity S .

The measurement function of GG01 is:

$$\Phi = U/S \quad \text{(Formula 0.1)}$$

The sensitivity is provided with GG01 on its product certificate.

There are three versions of GG01, each with a different rated measurement range, sensitivity, and response time. Irradiance ranges are $(250, 500, \text{ and } 1000) \times 10^3 W/m^2$ for GG01-250, GG01-500, and GG01-1000, respectively. The body is equipped with a flange for easy mounting. GG01-250 may be equipped with a sapphire window. See options in Table 1.

Gardon gauge technology

GG01 is made using oxygen-free, high thermal conductivity copper and a thin foil of a copper-nickel alloy. The all-metal sensor is called "Gardon gauge" after its inventor Robert Gardon. The benefit of this technology is that it can withstand extremely high heat fluxes.

GG01 has several advantages:

- withstands very high heat fluxes
- fast response time
- equipped with Type K thermocouple to measure body temperature
- suitable for use in high-vacuum environments
- safe transport and storage with a practical protection cap

Suggested use

GG01 is the sensor of choice for extremely high heat flux measurements.

Main applications are:

- solar concentrators
- flame research
- fluidized beds
- rocket engine exhaust flames

Calibration

GG01 sensors are factory calibrated according to ISO 14934-3. With that Hukx provides a calibration traceable to a secondary reference standard.

For GG01 250, 500, and 1000, the reference standard has been calibrated by comparison to the primary standard high temperature source of the [RISE Research Institutes of Sweden AB](#).

Hukx is ISO 9001 certified but not an ISO /IEC 17025 accredited measurement laboratory.

Manufacturing and testing

Hukx invested in brand new manufacturing and test equipment for producing modern Gardon gauges. Each sensor is tested at its rated range, up to $1000 \times 10^3 \text{ W/m}^2$.

All GG01s are tested to withstand a cooling water operating pressure of 10 bar.

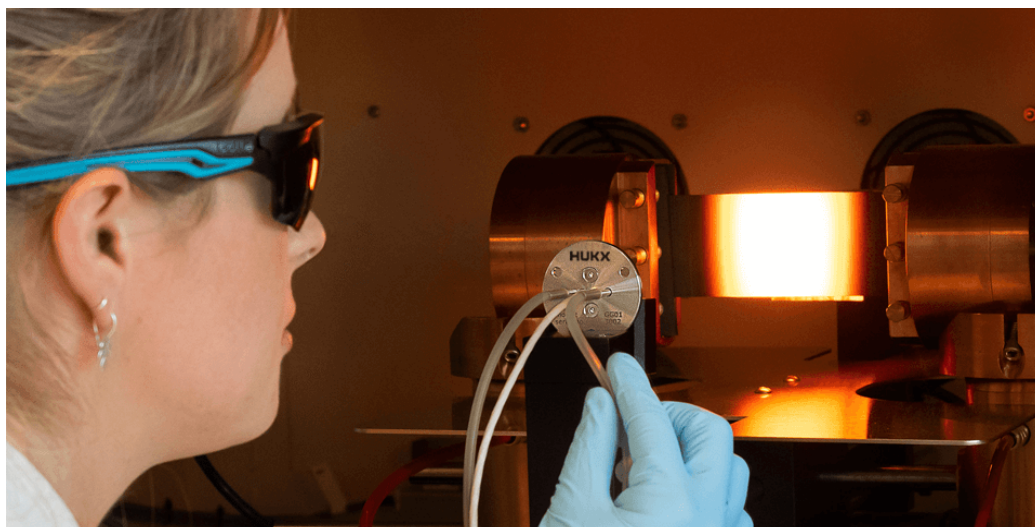

Figure 0.2 GG01 sensor in a high heat flux test cabinet.



Figure 0.3 On the left: GG01 showing its flange, cable and its tubes for water cooling. On the right: the practical protection cap; every GG01 sensor is supplied with one.

Measurement uncertainty

The measurement uncertainty of GG01 should be determined on a case-by-case basis. It depends on several factors:

1. heat flux sensor properties
2. uncertainty of calibration and quality assurance of the local calibration reference standard
3. verification of the sensor's stability in day-to-day measurements, both before and after use
4. application-related uncertainties, for example, caused by the unknown contribution of convection and the representativeness of the measurement location

The user should make his own uncertainty evaluation, see the chapter on this subject.

Options

- rated measurement ranges: $(250, 500, \text{ and } 1000) \times 10^3 \text{ W/m}^2$
- sapphire window (for GG01-250 only)
- longer cable: 5 or 10 m (standard cable: 2 m)

Optional sapphire window

GG01-250 may be equipped with an optional sapphire window (model GG01-250-SW). It allows the user to measure only the radiative component of the heat flux excluding the convective heat flux.

See also

- alternative model **SBG01** measures lower heat flux levels
- industrial model **HFS01** also measures high heat fluxes (up to $800 \times 10^3 \text{ W/m}^2$), is more robust, but has a slower response time than GG01. HFS01 is available with ATEX certification
- SBG04 water-cooled sensor—for cone calorimeters
- our complete range of **sensors and systems**



Figure 0.4 GG01-250-SW:
optionally GG01 can be
equipped with a sapphire
window.

1 Ordering and checking at delivery

1.1 Ordering GG01

The standard configuration of GG01 is with 2 metres cable.

Common options are:

- rated measurement range (250, 500, and 1000) x 10³ W/m²
- sapphire window (for GG01-250 only)
- longer cable (specify either 5 or 10 m)

Table 1.1.1 Ordering codes for GG01

Versions of GG01 (part numbers)	
GG01-250	Gardon gauge water-cooled high heat flux sensor, 250 kW/m ² rated measurement range
GG01-250-SW	Gardon gauge water-cooled high heat flux sensor, 250 kW/m ² rated measurement range, with sapphire window
GG01-500	Gardon gauge water-cooled high heat flux sensor, 500 kW/m ² rated measurement range
GG01-1000	Gardon gauge water-cooled high heat flux sensor, 1000 kW/m ² rated measurement range
Cable for GG01 (-SW)	
'-02' after GG01 part number	standard cable length: 2 m
'-05' after GG01 part number	cable length: 5 m
'-10' after GG01 part number	cable length: 10 m



Figure 1.1.1 GG01(-SW) is delivered with cable of the length as ordered and a protection cap

1.2 Included items

Arriving at the customer, the delivery should include:

- heat flux sensor GG01
- cable of the length as ordered
- product certificate matching the instrument serial number, including:
 - measurement range test report
- options as ordered

1.3 Quick instrument check

A quick test of the instrument can be done by connecting it to a multimeter.

1. Check the electrical resistance of the sensor between the black [-] and red [+] wires. Use a multimeter at the 10 Ω range. Measure the sensor resistance first with one polarity, then reverse the polarity. Take the average value. The typical resistance of the wiring is 0.1 Ω /m. Typical resistance should be the nominal sensor resistance of 0.8 Ω plus 0.2 Ω for the total resistance of two wires (back and forth) for each meter of cable. Infinite resistance indicates a broken circuit; zero indicates a short circuit.
2. Check the electrical resistance of the thermocouple between the white [-] and green [+] wires. Use a multimeter at the 100 Ω range. Measure the sensor resistance first with one polarity, then reverse the polarity. Take the average value. The typical resistance of the wiring is 2.5 Ω /m. Typical resistance should be the nominal thermocouple resistance of 0.1 Ω plus 5 Ω for the total resistance of two wires (back and forth) for each meter of cable. Infinite resistance indicates a broken circuit; zero indicates a short circuit.
3. Remove the white removable protection cap from the sensor. Check if the sensor reacts to heat: put the multimeter at its most sensitive range of DC voltage measurement. Expose the sensor to heat, for instance by putting a flame from a consumer type gas lighter at a distance of around 0.01 m. The signal should read positive in the order of 1×10^{-3} V DC. Do not expose for more than 10 s.
4. Inspect the sensor surface for any damage.
5. Check the sensor serial number against the certificate provided with the sensor.

2 Instrument principle and theory

The GG01 heat flux sensor measures radiation received by a plane surface from a 180° field of view angle. This quantity, expressed in W/m^2 , is called irradiance or heat flux density, and informally also heat flux. GG01 is designed to measure high heat fluxes, in the order of $100 \times 10^3 W/m^2$ and higher. The radiation spectrum of such sources typically extends from $(0.3 \text{ to } 10) \times 10^{-6} m$. By definition a heat flux sensor should cover that spectral range with a spectral selectivity that is as "flat" as possible. Using an open detector, GG01 is also sensitive to convective heat flux. This contribution is usually ignored.

In an irradiance measurement by definition the response to "beam" radiation varies with the cosine of the angle of incidence; i.e. it should have full response when the radiation hits the sensor perpendicularly (normal to the surface, 0° angle of incidence), zero response when the radiation has 90° angle of incidence, and 50 % of full response at 60° angle of incidence. A heat flux sensor should have a so-called "directional response" that is as close as possible to the ideal cosine characteristic.

In order to attain the proper directional and spectral characteristics, a heat flux sensor's main components are:

- a thermal sensor with black coating. It has a flat spectrum covering the $(0 \text{ to } 50) \times 10^{-6} m$ range, and has a near-perfect directional response. The coating absorbs all radiation and, at the moment of absorption, converts it to heat. The heat flows through a foil to the copper housing. A wire attached to the centre of the foil creates a single thermocouple. This thermocouple sensor generates a voltage output signal that is proportional to the irradiance.
- A water-cooled copper housing and metal body. These act as a heat sink.

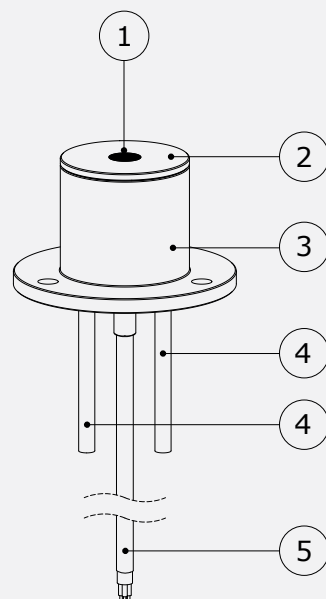

Figure 2.1. Overview of GG01 components:
(1) thermal sensor with black coating, (2) copper housing, (3) sensor body with flange, (4) water cooling tubes, (5) cable.

GG01 users typically assume that the measured heat flux is representative of the undisturbed irradiance at the location of the sensor. Users may also apply corrections based on scientific judgement.

Using GG01 is easy. For readout the user only needs an accurate voltmeter that works in the millivolt range. To convert the measured voltage, U , to a heat flux Φ , the voltage must be divided by the sensitivity S , a constant that is supplied with each individual sensor.

2.1 Gardon gauge technology

GG01 is made using a housing of oxygen-free high thermal conductivity copper, a thin foil of a copper-nickel alloy and a thin copper wire attached to the center of the foil.

This sensor construction is called "Gardon gauge" after its inventor Robert Gardon. It is first described in 1953 in his paper titled "**An Instrument for the Direct Measurement of Intense Thermal Radiation**".



Figure 2.1:1 GG01 showing its copper housing, metal body, black coating and cable.

2.2 Detailed measurement equation

In more detail, the measurement equation of GG01 is

$$\Phi = U/S + \sigma \cdot (T + 273.15)^4 \quad (\text{Formula 2.2.1})$$

In which the first term represents the incoming irradiance, and the second term represents the irradiance emitted by the sensor. The constant σ is the Stefan-Boltzmann constant $5.67 \times 10^{-8} \text{ W}/(\text{m}^2 \cdot \text{K}^4)$.

GG01 has an on-board thermocouple type K measuring body temperature.

In case the sensor temperature is of the order of $20 \text{ }^\circ\text{C}$, the second term is of the order of $0.4 \times 10^3 \text{ W}/\text{m}^2$, which is usually considered negligible, so that the measurement equation 2.1.1 is abbreviated to:

$$\Phi = U/S$$

(Formula 0.1)

Measuring with heat flux sensors, errors may be caused by differences between calibration reference conditions and the conditions during use. The user should analyse his own experiment and make his own uncertainty evaluation. Comments on the most common error sources can be found in the chapter about uncertainty evaluation.

2.3 Optional sapphire window

GG01 may be equipped with a sapphire (Al_2O_3) window. It allows the user to measure only the radiative component of the heat flux. The convective component is blocked. The sapphire window option is only available for the GG01-250 version.

It is typically used next to a standard GG01 which measures the total amount of heat flux (radiative plus convective heat flux).

Use of the sapphire window requires a dedicated uncertainty evaluation. See table 2.3.1 for relevant specifications.

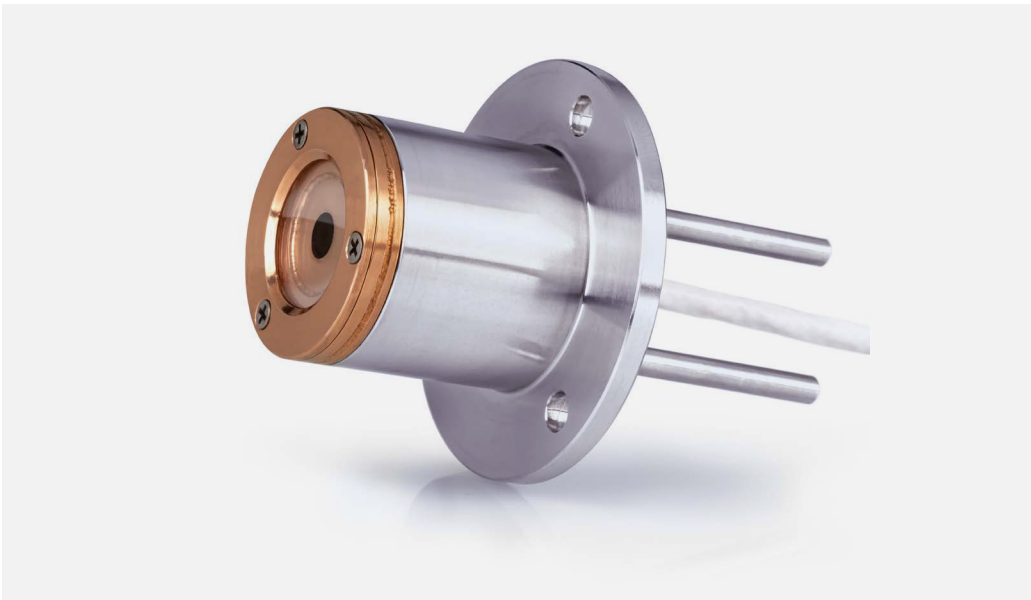

Figure 2.3.1 GG01-250-SW equipped with a sapphire window.

The sapphire window is attached using a copper mounting ring, and can be removed in between measurements.

GG01s with sapphire window are custom made, the sapphire window cannot be used on a standard GG01.

Table 2.3.1 Sapphire window specifications

Sapphire window	
option: sapphire window	sapphire window (250 x 10 ³ W/m ² version only)
ordering code	GG01-250-SW
full field of view angle	150°
spectral range	(0.2 to 5.5) x 10 ⁻⁶ m
transmission	86 % (at 1 x 10 ⁻⁶ m) transmission curve available upon request
tooling required for removal	Phillips #0 screwdriver

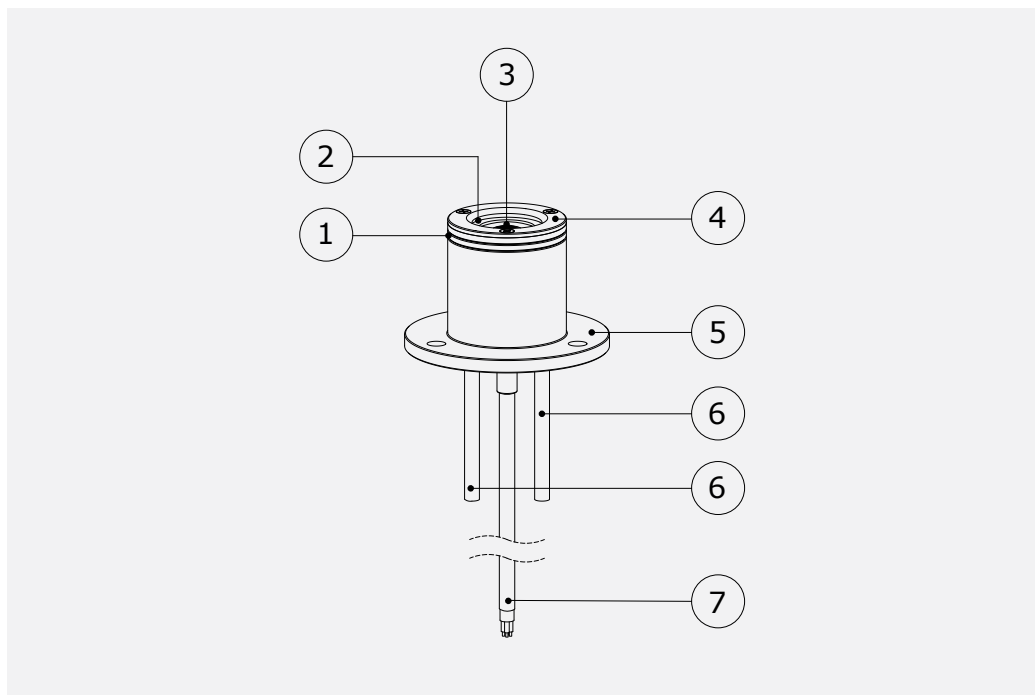

Figure 2.3.2 Overview of GG01-250-SW components: (1) copper housing, (2) sapphire window, (3) thermal sensor with black coating, (4) sapphire window mounting ring, (5) sensor body with flange, (6) water cooling tubes, (7) cable

3 Specifications

3.1 GG01 specifications

GG01 measures the heat flux density through the surface of the sensor. This quantity, expressed in W/m^2 , is called heat flux. GG01 is rated for use in environments in which the heat flux is dominated by radiation at heat flux levels $> 100 \times 10^3 W/m^2$. Working completely passive, using a thermopile sensor, GG01 generates a small output voltage proportional to this flux. Using an open detector, GG01 is also sensitive to convective heat flux. This contribution is usually ignored. The sensor's rated measurement range must be chosen to match the heat flux level as close as possible. It must be water cooled or exposed only for a limited time interval. GG01 can only be used in combination with a suitable measurement system. In testing, the sensor must be calibrated and used in accordance with the recommended practices of ISO and ASTM.

Table 3.1.1 Specifications of GG01 (continued on next pages)

gg01 specifications	
sensor type	sapphire window ($250 \times 10^3 W/m^2$ version only)
sensor type according to ISO 14934	total heat flux sensor
measurand	heat flux
measurand in SI units	heat flux density, irradiance in W/m^2
heat flux sensor	thermocouple
sensor technology	Gardon gauge
temperature sensor	thermocouple type K
rated measurement ranges	(250, 500 and 1000) $\times 10^3 W/m^2$
limiting measurement range	150% of rated measurement range
sensing area diameter	
$250 \times 10^3 W/m^2$	$6.3 \times 10^{-3} m$
$500 \times 10^3 W/m^2$	$5.3 \times 10^{-3} m$
$1000 \times 10^3 W/m^2$	$4.3 \times 10^{-3} m$
output signal	DC voltage

sensitivity (nominal)	
250 x 10 ³ W/m ²	24 x 10 ⁻⁹ V/(W/m ²)
500 x 10 ³ W/m ²	15 x 10 ⁻⁹ V/(W/m ²)
1000 x 10 ³ W/m ²	8 x 10 ⁻⁹ V/(W/m ²)
output signal range	> 4 x 10 ⁻³ V at rated measurement range
measurement function / required programming	$\Phi = U/S$
optional measurement function	$\Phi = U/S + \sigma \cdot (T + 273.15)^4$
required readout	heat flux sensor: 1 x differential voltage channel temperature sensor: 1 x Type K differential thermocouple channel both with input resistance > 10 ⁶ Ω
rated operating temperature range	apply sufficient cooling water to maintain a cooling water outlet temperature below 80 °C -30 to +800 °C (sensor, copper housing) -30 to +650 °C (black coating) -30 to +250 °C (cable) -30 to +200 °C (sensor body) -30 to +105 °C (cable termination ends)
use in vacuum	suitable for use in high vacuum (> 10 ⁻¹⁰ bar) GG01 can show outgassing. In sensitive applications it is recommended to clean GG01 by performing a vacuum outgassing test.
temperature dependence	< 0.2 %/°C
non-linearity	full rated measurement range, with respect to calibration reference condition
250 x 10 ³ W/m ²	< 2 %
500 x 10 ³ W/m ²	< 1 %
1000 x 10 ³ W/m ²	< 0.5 %
black coating emissivity	> 0.9
spectral range	(0 to 50) x 10 ⁻⁶ m
full field of view angle	180°
Response times (63 %)	
250 x 10 ³ W/m ²	< 250 x 10 ⁻³ s
500 x 10 ³ W/m ²	< 200 x 10 ⁻³ s
1000 x 10 ³ W/m ²	< 100 x 10 ⁻³ s

sensor resistance	1.2 Ω (nominal)
required sensor power	zero (passive sensor)
rated operating relative humidity range	0 to 100 % (non condensing)
standard cable length	2 m (see options)
cable material type	PTFE
cable diameter	3.3 x 10 ⁻³ m
sensor marking	serial number engraved on sensor body
gross weight including 2 m cable and protection cap	approx. 0.5 kg
net weight including 2 m cable and protection cap	approx. 0.5 kg
water cooling	
typical cooling method	tap water at 3 bar supplied through and drained through a silicone hose
alternative cooling method	actively cooling water circulator with water pump instead of tap water
rated exposure time interval	indefinite when water cooled
rated cooling water operating pressure range	0 to 10 bar
rated cooling water flow	50 l/hr (0.014 l/s) apply sufficient cooling water to maintain a cooling water outlet temperature below 80 °C required cooling water flow depends on level of heat flux, installation and condition of the sensor. See chapter on cooling.
rated cooling water temperature range	10 to 30 °C
use without water cooling	GG01 may be used uncooled at low heat flux levels or for short time intervals. See the chapter on uncooled sensors in this manual for directions
weight of metal sensor housing and body	0.01 kg

metal heat capacity	390 J/(kg·K) (housing) 500 J/(kg·K) (body)
heat capacity of sensor housing and body	44 J/K
recommended tubing for cooling water supply	through 6 x 10 ⁻³ m outer diameter / 3 x 10 ⁻³ m inner diameter silicone hose outer diameter of metal tubes on sensor body: 3.175 x 10 ⁻³ m (1/8 inch)
use in testing	
standards governing use of the instrument	SO 14934-1: Reaction-to-Fire Tests - use of heat flux meters general principles ISO 14934-4: Reaction-to-Fire Tests - guidance on use of heat flux meters
suitable for use in test	ISO 5657: Reaction to fire tests - Ignitability of building products using a radiant heat source ISO 5658: Reaction to fire tests - Spread of flame ISO 5660: Reaction to fire tests - Heat release, smoke production and mass loss rate ISO 17554 Reaction to fire tests -- Mass loss measurement ISO 9705:1993 Fire tests — Full-scale room test for surface products ISO 17431:2006 Fire tests - Reduced-scale model box test ISO 13785: Reaction to fire test for façades -part 1 and 3 ISO 3008: Fire resistance tests - door and shutter assemblies ISO 5659: Plastics — Smoke generation — Part 2: Determination of optical density by a single-chamber test ISO 14696: Reaction-to-fire tests — Determination of fire and thermal parameters of materials, products and assemblies using an intermediate-scale calorimeter (ICAL) Cargo Compartment Liners

suitable for use in test

ISO 13785: Reaction-to-fire tests for façades- part 1 intermediate scale and part 2 large scale

ISO 9239: Reaction to fire tests for floorings — Part 1: Determination of the burning behaviour using a radiant heat source

FAA FAR PART 25 APPENDIX F PART 3: Test Method to Determine Flame Penetration Resistance of Cargo Compartment Liners

ASTM E285 – 08(2015): Standard Test Method for Oxyacetylene Ablation Testing of Thermal Insulation Materials

installation and use

typical conditions of use

in experiments, in industrial research environments. Exposed to high heat fluxes for periods of several seconds to several hours. Connected to user-supplied data acquisition equipment. Regular inspection of the sensor surface, housing, body and water supply. Continuous monitoring of sensor temperature and water supply. No special requirements for immunity, emission, chemical resistance.

installation

see recommendations in this manual

cable extension

see chapter on cable extension or order sensors with longer cable

recoating

ISO 14934-4 paragraph 9.1 allows repainting of sensors, according to manufacturer recommendations. After repainting, the sensors must be re-calibrated.
See chapter on recoating / repainting of sensor surfaces

calibration

calibration traceability

to ITS-90

standard governing calibration

ISO 14934-3: Reaction-to-Fire Tests - calibration of heat flux meters secondary calibration

product certificate

included (showing calibration result and traceability)

measurement range test report

included

calibration method	SBGC secondary calibration method according to ISO 14934-3. The Hukx SBGC method follows the recommended practice of ISO 14934-3, however we calibrate at one heat flux level only. Calibration relies on a comparison to a secondary standard heat flux sensor under a radiant heat source as described in paragraph 5.1. The calibration reference has been characterised in the range of (0 to 75) x 10 ³ W/m ² . Calibration at is done at 100 x 10 ³ W/m ² , using linear extrapolation of the sensitivity of the calibration reference.
calibration laboratory accreditation	not accredited
calibration laboratory management system certification	ISO 9001
calibration hierarchy	from SI through international standards and through an internal mathematical procedure
calibration uncertainty	< ± 6.5 % (k = 2)
recommended recalibration interval of working standards	fire tests may specify the interval of calibration of the working standard heat flux sensor. We recommend to calibrate before and after every test.
recommended maintenance of calibration reference standards	we recommend that accredited test laboratories follow the procedures described in ISO 14934-3 Annex D. They must have 3 calibration reference sensors (secondary standards, calibrated externally against a primary standard according to ISO 14934-2), used to calibrate the working standards. One of these should be designated as "principal". Clause D.14 recommends that every year one of the 3 instruments is recalibrated against the (external) primary standard. Calibration against a primary standard may be done at RISE (Sweden) or NIST (USA)
calibration reference conditions	cooling water temperature < 25 °C, heat flux 100 x 10 ³ W/m ²
validity of calibration	based on experience, the instrument sensitivity will not change during storage
measurement accuracy	
uncertainty of the measurement	statements about the overall measurement uncertainty can only be made on an individual basis. see the chapter on uncertainty evaluation.

standard governing uncertainty evaluation in tests

ISO 29473 Fire test - Uncertainty of measurements in fire tests

versions/options

version: rated measurement range

(250, 500, 1000) x 10³ W/m²

order code standard version

GG01/rated measurement range/cable length

option: longer cable

specify either 5 or 10 m

option: sapphire window

sapphire window (250 x 10³ W/m² version only)

accessories

spare part

removable protection cap GG01
(included with each GG01 delivery)

accessory

handheld read-out unit LI19
programmed LI19 handheld read-out unit /
datalogger, two spare batteries, one USB
cable, software and a transport case

3.2 Dimensions of GG01

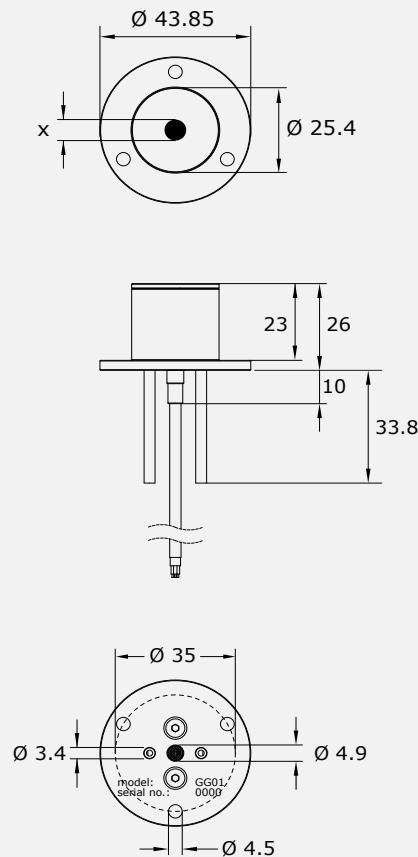

Figure 3.2.1 GG01 dimensions in x 10⁻³ m. From top to bottom: view of front, side and back.

'x' is the diameter of the sensing area. This diameter varies with the rated measurement ranges of GG01.

sensing area diameter x	
GG01-250	$6.3 \times 10^{-3} \text{ m}$
GG01-500	$5.3 \times 10^{-3} \text{ m}$
GG01-1000	$4.3 \times 10^{-3} \text{ m}$

3.3 Dimensions of GG01-SW

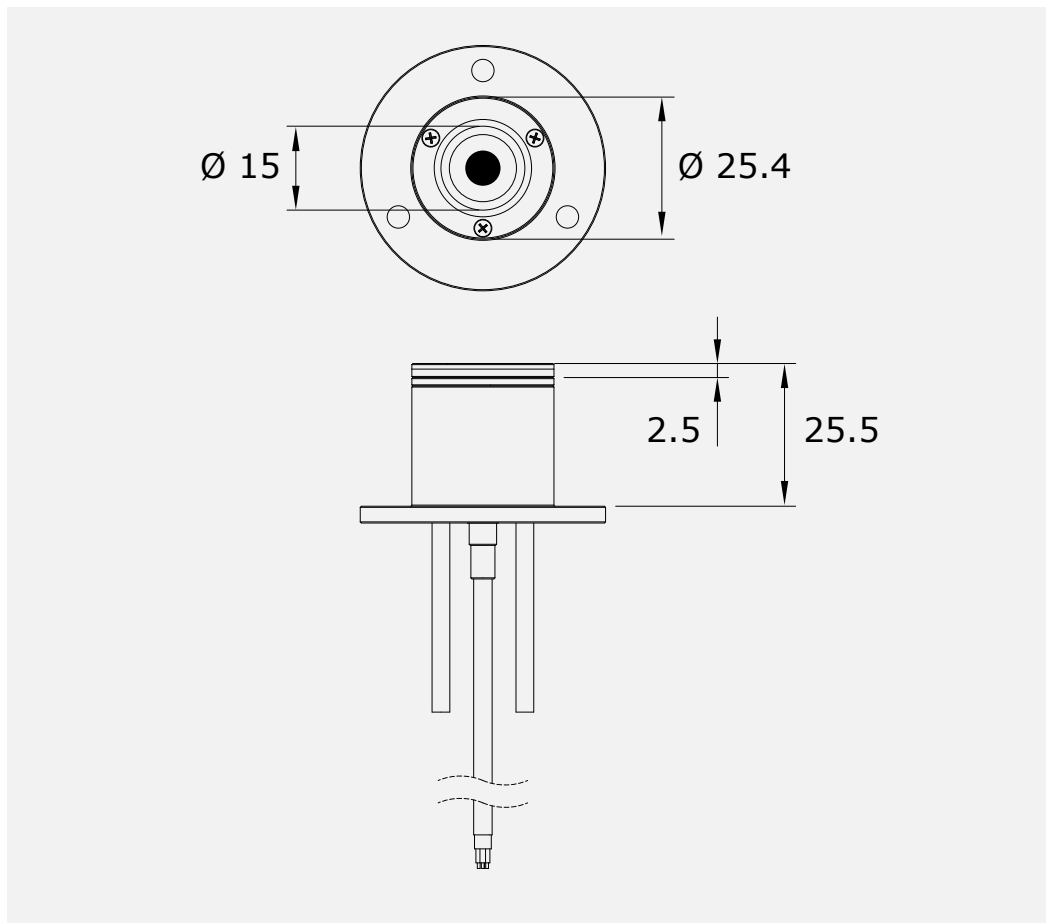

Figure 3.31 GG01 with sapphire window, dimensions in 10^{-3} m . The window is added to a standard GG01. GG01s with sapphire window (GG01-250-SW) are custom made, the sapphire window cannot be used on a standard GG01. For other dimensions, see previous section on GG01 dimensions.

4 Standards and recommended practices for use

GG01 should be used in accordance with the recommended practices of ISO and ASTM.

4.1 Heat flux measurement in fire testing: ISO 14934

Calibration and use of heat flux sensors (officially "heat flux meters") such as GG01 is subject to standardised practices according to ISO 14934 "Reaction-to-Fire tests - calibration of heat flux meters". The same procedures will be adopted by ASTM. In case the user performs accredited testing or works in an accredited organisation, the user must comply with these standards. The ISO 14934 standard has 4 parts. We recommend users to purchase the latest version of the standard.

Table 4.1.1 Standards with recommendations for instrument use in fire testing

standards for heat flux sensor use in fire testing	
ISO standard	equivalent ASTM standard
ISO 14934 "Reaction-to-Fire tests - calibration of heat flux meters" Part 1: general principle Part 2: primary calibration methods Part 3: secondary calibration methods Part 4: guidance on use of heat flux meters	No equivalent ASTM standard

The most important requirements of the standard are:

- to have 3 local "secondary standard" calibration reference standards (i.e. sensors calibrated against a primary standard according to ISO14934-2) for calibration of the "working standards" (i.e. the instruments used for day to day work for calibration of test equipment). Calibration according to ISO 14934-2 may be done at RISE (Sweden) or NIST (USA). Of the 3 calibration reference instruments, 2 instruments must be kept unused until unexpected results appear or until the first calibration reference standard is sent away for recalibration. A typical expanded uncertainty of the sensitivity at RISE is in the order of 2 to 3 % ($k = 2$) in a range from 5 to 75 x 10³ W/m².
- to calibrate every 2 years one of the reference standards against a primary standard. After calibration this instrument is used to verify the uncertainty of the other 2 calibration reference standards. A single reference standard is usually calibrated at multiple heat flux levels. It can be used as a reference in the same heat flux range, and by extrapolation also at higher levels.

- to use working standards only at an irradiance level close to its calibration reference condition.
- to compare working standards to a local reference standard before every test and preferably after every test, following the method specified in ISO 14934-3. The comparison requires a local irradiance source, for example a cone calorimeter.

5 Installation

Table 5.1.1 Recommendations for installation of heat flux sensors in fire testing

standard operating practices	If the test is carried out in accordance to a standard: look for recommendations in the standard.
orientation	The sensor will work in any orientation.
protection cap	use the cap during transport and storage. Remove the cap when installing and during measurements.
water cooling	Usually tap water is used, supplied and led out through silicone hoses. See the chapter on cooling.
electrical connection	The sensor and thermocouple generate a small voltage output signal. No power supply is required. Connect the signal wires to a data acquisition system. See the chapter on electrical connection.
signal amplification	See the paragraph on electrical connection.
mechanical mounting	<p>Use the 3 holes in the flange for sensor mounting. Make sure that the object that is used for mounting the flange remains relatively cool. Heat should not conduct easily through the flange to the sensor body.</p> <p>Usually the cables are provided with an additional strain relief.</p>
heat shielding	Shield the body sensor and cable as much as possible from radiated and convective heat.

5.2 Electrical connection

A heat flux sensor should be connected to a measurement system, typically a so-called datalogger. GG01 is a passive sensor that does not need any power.

Cables may act as a source of distortion, by picking up capacitive noise. We recommend keeping the distance between a datalogger or amplifier and the sensor as short as possible. For cable extension, see the appendix on this subject.

Table 5.2.1 The electrical connection of GG01

Wire		measurement system
Red	signal [+]	voltage input [+]
Black	signal [-]	voltage input [-]
Green	thermocouple [+]	thermocouple input [+]
White	thermocouple [-]	thermocouple input [-]
Grey	shield	ground

5.3 Requirements for data acquisition/amplification

The selection and programming of dataloggers is the responsibility of the user

Table 5.3.1 The electrical connection of GG01

capability to measure small voltage signals	preferably: $< 5 \times 10^{-6} \text{ V}$ uncertainty minimum requirement: $20 \times 10^{-6} \text{ V}$ uncertainty (valid for the entire expected temperature range of the acquisition / amplification equipment)
capability for the data logger or the software	to store data, and to perform division by the sensitivity to calculate the heat flux. $\Phi = U/S$ (Formula 0.1)
data acquisition input resistance	$> 1 \times 10^6 \Omega$
Open circuit detection (WARNING)	open-circuit detection should not be used, unless this is done separately from the normal measurement by more than 5 times the sensor response time and with a small current only. Thermopile sensors are sensitive to the current that is used during open circuit detection. The current will generate heat, which is measured and will appear as a temporary offset.

5.4 Cooling

Apply sufficient cooling water to maintain a cooling water outlet temperature below 80 °C.

Required cooling water flow depends on level of heat flux, installation and condition of the sensor.

For normal applications in fire research, the standard 3 bar pressure of tap water supply is sufficient for operating heat flux meters. In case of extremely high fluxes, additional pressure may be necessary.

Water has a very high heat capacity of 4200 J/(kg·K). A water supply of 30 l/hr, which is a mass flow rate of 0.01 kg/s, is sufficient to carry away 350 W of heater with a temperature rise of 10 °C.

If the entire surface area of the sensor absorbs 100 % of the incoming heat flux (for example in high soot conditions), $100 \times 10^3 \text{ W/m}^2$ of heat flux equals 50 W of absorbed heat for 1 inch diameter sensors.

An alternative possibility is to use a large vessel filled with water or coolers such as supplied by the Julabo company, for example their FL1703 Recirculating Cooler. The Julabo equipment is a closed-circuit water cooler with a convective heat exchanger.



Figure 5.4.1 Example of an active water cooler with a pump: Julabo FL1703.

5.5 Uncooled sensors

GG01 may be used non-cooled (so not connected to the water supply).

This can be considered if:

1. the exposure is so short that GG01 does not significantly heat up; typically this requirement is fulfilled in case the time is less than 1 second
2. the flux is so low that GG01 cannot significantly heat up; typically this requirement is fulfilled in case fluxes are $< 10 \times 10^3 \text{ W/m}^2$. In this case it is relevant to consider that the measurement will be inaccurate because of the non-linearity and emission of radiation by the sensor itself
3. there is a large additional heat sink (for instance a block of metal or melting stearin) attached to GG01

In all cases we recommend:

4. to verify that the temperature of the sensor body remains below 200 °C (the body is made of stainless steel, but internal wiring connections near the flange risk failure above 200 °C)
5. to minimize the exposed surface area by adding heat shields and insulation
6. to calculate temperature rise before experimenting; the GG01 housing and body weight is around 0.10 kg, and have a combined heat capacity of 44 J/K
7. add as much thermal mass as possible

6

Making a dependable measurement

6.1 Uncertainty evaluation

The measurement uncertainty is a function of:

- calibration uncertainty
- differences between reference conditions during calibration and measurement conditions, for example uncertainty caused by non-linearity
- damage during sensor employment
- application errors: the measurement conditions and environment in relation to the sensor properties, the influence of the sensor on the measurand, the representativeness of the measurement location
- convective heat transport

It is not possible to give one figure for heat flux sensor measurement uncertainty. Statements about the overall measurement uncertainty can only be made on an individual basis, taking all these factors into account.

Guidelines for uncertainty evaluation:

- 1) The formal evaluation of uncertainty should be performed in accordance with ISO 98-3 Guide to the Expression of Uncertainty in Measurement, GUM.
- 2) Uncertainties are entered in measurement equation (equation is usually Formula 0.1: $\Phi = U/S$), either as an uncertainty in E (non-representativeness, resistance error and deflection error) in U (voltage readout errors) or in S (non-stability, temperature dependence, calibration uncertainty).
- 3) In case of special measurement conditions, typical specification values are chosen. These should for instance account for environmental conditions (working temperature range).
- 4) Among the various sources of uncertainty, some are "correlated"; i.e. present during the entire measurement process, and not cancelling or converging to zero when averaged over time; the off-diagonal elements of the covariance matrix are not zero. Paragraph 5.2 of GUM.
- 5) Among the various sources of uncertainty, some are "uncorrelated"; cancelling or converging to zero when averaged over time; the off-diagonal elements of the covariance matrix are zero. Paragraph 5.1 of GUM.

6.2 Contributions to the uncertainty budget

6.2.1 Calibration uncertainty at Hukx

GG01's factory calibration uncertainty under reference conditions is $\pm 6.5\%$ with a coverage factor $k = 2$.

As a user of GG01 you may attain a similar uncertainty when calibrating against your local calibration reference standard.

6.2.2 Uncertainty caused by non-linearity

The GG01 is calibrated at $100 \times 10^3 \text{ W/m}^2$. When measuring at any heat flux level, the sensor output ideally varies linearly with the heat flux. The deviation from this ideal behaviour is captured in the so-called non-linearity. The non-linearity is expressed as a maximum percentage deviation of the sensitivity at the rated measurement range with respect to calibration reference condition of a heat flux of $100 \times 10^3 \text{ W/m}^2$.

For a GG01-250, when measuring a heat flux of $250 \times 10^3 \text{ W/m}^2$, an extra uncertainty of 2 % on the sensitivity should be added as a source of uncertainty.

6.2.3 Uncertainty caused by convection

GG01 is calibrated for radiative heat flux.

The GG01 sensor is not shielded. Convective heat transport, typically by hot gasses, may act as a source of measurement error. To estimate the associated uncertainty, the user may design experiments to vary local heat transfer.

The GG01-250 is optionally available with a sapphire window to eliminate convective heat transport from the measurement.

7 Maintenance and trouble shooting

7.1 Recommended maintenance and quality assurance

GG01 is typically located in hostile environments in which the sensor is under constant threat of being damaged. Unreliable measurement results are detected by very frequent recalibration, by visual inspection of the sensor and by scientific judgement, for example by looking for unreasonably large or small measured values. Preferably the measurement is done by multiple sensors, which makes it possible to check against other measurements.

Table 7.1.1 The electrical connection of GG01

minimum recommended heat flux sensor maintenance			
Interval	Subject	Action	
1	before and after every test	recalibration	recalibrate against a local calibration reference
2	before and after every test	inspection	inspect sensor coating, cable quality, inspect mounting, inspect the water supply tubing
3	after every test	data review	judge the feasibility of the measurement data compare to measurements with other sensors, typically heat flux and temperature measurements
4	after every test	lifetime assessment	judge if the instrument will be reliable for another test

7.2 Trouble shooting

Table 7.2.1 Trouble shooting for GG01 (continued on next page).

<p>general</p>	<p>Inspect the sensor for any damage.</p> <p>Inspect if the wires are properly attached to the data logger.</p> <p>Check the condition of the cable.</p> <p>Check the datalogger program in particular if the right sensitivity is entered.</p> <p>Check the electrical resistance of the sensor between the black [-] and red [+] wires. Use a multimeter at the 10 Ω range. Measure the sensor resistance first with one polarity, then reverse the polarity. Take the average value. The typical resistance of the wiring is 0.1 Ω/m. Typical resistance should be the nominal sensor resistance of 0.8 Ω plus 0.2 Ω for the total resistance of two wires (back and forth) for each meter of cable. Infinite resistance indicates a broken circuit; zero indicates a short circuit.</p> <p>Check the electrical resistance of the thermocouple between the white [-] and green [+] wires. Use a multimeter at the 100 Ω range. Measure the sensor resistance first with one polarity, then reverse the polarity. Take the average value. The typical resistance of the wiring is 2.5 Ω/m. Typical resistance should be the nominal thermocouple resistance of 0.1 Ω plus 5 Ω for the total resistance of two wires (back and forth) for each meter of cable. Infinite resistance indicates a broken circuit; zero indicates a short circuit.</p>
<p>The sensor does not give any signal</p>	<p>Remove the white removable protection cap from the sensor.</p> <p>Check if the sensor reacts to heat: put the multimeter at its most sensitive range of DC voltage measurement. Expose the sensor to heat, for instance by putting a flame from a consumer type gas lighter at a distance of around 0.01 m. The signal should read positive in the order of 1×10^{-3} V DC. Do not expose for more than 10 s.</p> <p>Check the data acquisition by replacing the sensor with a spare unit.</p>
<p>The sensor signal is unrealistically high or low</p>	<p>Check the cable condition looking for cable breaks.</p> <p>Check the data acquisition by applying a 1×10^{-6} V source to it in the 1×10^{-6} V range. Look at the measurement result. Check if it is as expected.</p> <p>Check the data acquisition by short circuiting the data acquisition input with a 10 Ω resistor. Look at the output. Check if the output is close to 0 W/m².</p>

The sensor signal shows unexpected variations	Check the presence of strong sources of electromagnetic radiation (radar, radio).
	Check the condition and connection of the shield.
	Check the condition of the sensor cable.
	Check if the cable is not moving during the measurement.

7.3 Recoating/repainting of sensor surfaces

ISO 14934-4 paragraph 9.1 allows repainting of sensors, according to manufacturer recommendations.

Hukx recommendations are:

Repainting is preferably done by the manufacturer. Do-it-yourself repainting is possible, but if that is done all product warranties are cancelled.

Judge by visual inspection if the thermopile sensor is still well attached to the metal sensor body. If not, the sensor is beyond repair. Verify sensor functionality. This can also be done with a non-coated sensor (see the chapter of the quick sensor test).

Purchase a matt (not glossy) black paint which is temperature resistant up to 650 °C. Typically aerosol spray cans are most easy to use, but such paints can also be used purchased in cans. In case a solvent is needed: typically acetone is a good solvent for these paints.

Surface preparation: In case the existing sensor surface coating has small scratches but is otherwise in good condition, do not clean, but apply new paint directly to the existing paint. In case of heavy damage to sensor surface coatings: remove the existing coating, clean with acetone. Lightly sand the grey metal surface.

Paint application: the sensor surface is located in a 0.1×10^{-3} m deep locally lower surface in the GG01 body. Spray some paint in a small cup, use a pipette to apply one drop of paint. In case a pipette is not available, use a small paint brush.

Curing: most coatings require curing to reach the required temperature specification. Cure the coating according to the manufacturer recommendation. Be careful not to expose the sensor body to temperatures above 200 °C. The cable termination ends are specified to a maximum temperature of 105 °C. When placing the sensors in an oven, leave the cable outside the oven.

Recalibration: newly coated sensors should be recalibrated. We do not expect significant (> 5 %) changes relative to the original sensitivity.

7.3.1 Hukx factory coating process

Hukx uses RUST-OLEUM® Hard Hat 7778 Bar-B-Q-Black.

The coating is cured for 200 minutes at a temperature of 160 °C. This temperature is reached with a ramp of 1 °C/min.

8 Appendices

8.1 Appendix on cable extension/replacement

GG01 is equipped with one cable, and is available in cable lengths of 2, 5 and 10 m.

Cables may act as a source of distortion by picking up capacitive noise. Keep the distance between data logger or amplifier and sensor as short as possible.

In an electrically "quiet" environment the GG01 cable may be extended without problem. If done properly, the sensor signal, although small, will not significantly degrade because the sensor resistance is very low (which results in good immunity to external sources) and because there is no current flowing (so no resistive losses).

Cable and connection specifications are summarised below.

Table 8.1.1 Preferred specifications for cable extension of GG01.

cable	4-wire, shielded, with 2 copper conductors and 2 type K thermocouple conductors
Extension sealing	make sure any connections are sealed against humidity ingress
Conductor resistance	< 0.1 Ω/m
Outer diameter	typically 3×10^{-3} m
Length	cables should be kept as short as possible, in any case the total cable length should be less than 100 m
Outer mantle	with the proper temperature specifications. Typically the mantle and cladding are made of PTFE
Connection	either solder the new cable conductors and shield to those of the original sensor cable, and make a waterproof connection using heat-shrink tubing with hot-melt adhesive, or use gold plated waterproof connectors. Always connect the shield

8.2 Appendix on calibration hierarchy

GG01 factory calibration is traceable from SI through international standards and through an internal mathematical procedure. The formal traceability of the generated heat flux is through a secondary standard calibration reference to the international temperature standard ITS90.

The Hukx SBGC method follows the recommended practice of ISO 14934-3, however we calibrate at one heat flux level only. Calibration relies on a comparison to a secondary standard heat flux sensor under a radiant heat source as described in paragraph 4.1. The calibration reference has been characterised in the range of 0 to $75 \times 10^3 \text{ W/m}^2$. Calibration is done at $100 \times 10^3 \text{ W/m}^2$, using linear extrapolation of the sensitivity of the calibration reference.

8.3 Appendix on typical heat flux ranges

Irradiance from blackbody covering 180° full field of view angle.

Table 8.3.1 Irradiated heat flux versus equivalent blackbody source temperature calculated using Stefan Boltzmann's law.

	$\times 10^3 \text{ W/m}^2$	equivalent blackbody temperature °C
1	0.4	10
2	20	500
3	60	750
4	150	1000
5	300	1250
6	560	1500
7	700	1600
8	860	1700
9	1050	1800
10	1265	1900
11	1515	2000

Table 8.3.2 Typical ranges of heat flux levels, from ISO 14934-4.

	x 10³ W/m²	comment
1	300	maximum level in a fully developed fire
2	200 to 100	incident heat flux on the wall in a developed fire enclosure
3	about 100	radiation from burning house
4	about 30	causing ignition of tree
5	20 to 10	causing ignition of timber
6	about 7 or 8	lowest level for causing ignition of a timber wall under a pilot flame
7	about 4	lowest level for causing a burn
8	about 2.5	highest level for people to endure
9	1.5	solar constant, maximum level of solar irradiance

Table 8.3.3 Typical ranges of heat flux levels, from ISO 5569 (continued on next page).

	x 10³ W/m²	comment
1	300	jet fire peak
2	200	jet fire average and fully developed fire > 10 x 10 ⁶ W
3	140	premixed blow torches oxyacetylene
4	120 to 145	peak floor values in post flashover room fires
5	115 to 230	peak wall values in post flashover room fires
6	105 to 175	peak ceiling values for post flashover room fires
7	90 to 200	average wall values for post flashover room fire
8	70 to 150	average ceiling values for post flashover room fire
9	50 to 150	high ventilation fully developed room fire 5 % to 10 % O ₂ by volume
10	60 to 120	premixed gas burner

11	40 to 115	on facade 0,8 m to 3,3 m above window at lintel
12	40 to 70	low ventilation fully developed fire 1% to 5 % O ₂ by volume
13	30 to 40	small (up to 250 mm high) gas diffusion flames
14	25 to 45	flux on wall from vertical wall burning
15	25	flux below vertical spreading wall flame
16	<25	oxidative pyrolysis fire 5 % to 21 % O ₂ by volume
17	20 to 40	developing fire with 10 % to 15 % O ₂ by volume
18	20 to 25	heat flux at floor level in flashover fire with ceiling temperature > 600 °C
19	18 to 20	match flames
20	10 to 40	output from waste paper basket fires
21	12 to 22	critical ignition flux of many materials, e.g. polyethylene, polyacetal, PMMA, wood, hardboard

8.4 Appendix on sensor design: Gardon versus Schmidt-Boelter

The general name for the GG01 type sensor is nowadays “total heat flux meter”: according to ISO 14934-1 paragraph 3 definition 3.17, and Annex A.2.

The so-called Gardon and Schmidt-Boelter designs (named after their inventors) are also “total heat flux meters”. From a metrology point of view there is no difference. They all measure heat flux and are traceable to the same reference. The discussion what design to use is not relevant. New standards in fire testing will probably avoid using the Gardon or Schmidt-Boelter names.

8.5 EU declaration of conformity

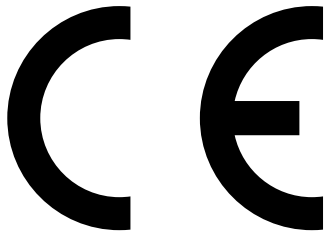

We, Hukseflux Thermal Sensors B.V.,
Delftechpark 31, 2628 XI, Delft,
The Netherlands

in accordance with the requirements of the following directive:

2011/65/EU The Restriction of Hazardous Substances Directive

hereby declare under our sole responsibility that:

Product model	GG01
Product type	Water-cooled heat flux sensor
Brand name	Hukx

has been designed to comply and is in conformity with the relevant sections and applicable requirements in the directive under typical conditions of use as defined in product specifications.

Eric HOEKSEMA
Director
Delft, 22 May 2024

About Hukx

Hukx is the leading innovator in solar radiation and heat flux sensor technology. We are proud to set the standard in high-accuracy measurement, and to be working at the heart of the energy transition.

Customers worldwide rely on our bestselling pyranometers and heat flux sensors. From sensor design and selection to supply and recalibration, we support you across the entire lifecycle.

Hukx is headquartered in the Netherlands, with locally owned representative sales offices in the USA, Brazil, India, China, Southeast Asia, and Japan.

Let us help you select the best sensor for your application. Get in touch with our experts today via: info@hukx.com

© Hukx

Version 2506

We reserve the right to change specifications without prior notice.

www.hukx.com

HUKX