

HUKX

Sensor
Technology

User manual
Foil heat flux sensor

FHF06

Cautionary statements

Cautionary statements are subdivided into four categories: danger, warning, caution and notice according to the severity of the risk.

DANGER

Failure to comply with a danger statement will lead to death or serious physical injuries.

WARNING

Failure to comply with a warning statement may lead to risk of death or serious physical injuries.

CAUTION

Failure to comply with a caution statement may lead to risk of minor or moderate physical injuries.

NOTICE

Failure to comply with a notice may lead to damage to equipment or may compromise reliable operation of the instrument.

Contents

Introduction	5
1 Ordering and checking at delivery	8
1.1 Ordering FHF06	8
1.2 Included items	8
1.3 Quick instrument check	9
2 Instrument principle and theory	10
2.1 What a heat flux sensor is and how it works	10
2.2 Selecting a suitable FHF06 heat flux sensor model	13
3 Specifications of FHF06	14
3.1 Specifications of FHF06	14
3.2 Dimensions of FHF06 series	19
4 Standards and recommended practices for use	20
4.1 Heat flux measurement in industry	20
5 Installation of FHF06	21
5.1 Why to avoid air gaps	21
5.2 Site selection and installation	22
5.3 Installation on curved surfaces	25
5.4 Electrical connection	26
5.5 Requirements for data acquisition/amplification	30
6 Maintenance and trouble shooting	31
6.1 Recommended maintenance and quality assurance	31
6.2 Trouble shooting	32
6.3 Validation and calibration	35
7 Appendices	36
7.1 Appendix on cable and cable extension	36
7.2 Appendix on installation of FHF06 sensor foil	38
7.3 Appendix on standards for calibration	40
7.4 Appendix on calibration hierarchy	41
7.5 Appendix on correction for temperature dependence	41
7.6 Appendix on measurement range for different temperatures	42
7.7 Appendix on temperature measurement accuracy	43
7.8 Appendix on use of FHF sensor foils at low temperatures to -200 °C	44
7.9 Appendix on use of FHF sensor foils under vacuum conditions	46
7.10 Appendix on long-term use in condensing, wet, and underwater conditions	47
7.11 Appendix on use of FHF sensor foils under pressure	48
7.12 EU declaration of conformity	49

List of symbols

quantities	symbol	unit
heat flux	Φ	W/m ²
voltage output	U	V
sensitivity	S	V/(W/m ²)
temperature	T	°C
thermal resistance per unit area	R _{thermal,A}	K/(W/m ²)

subscripts	
property of heatsink	heatsink
maximum value, specification limit	maximum

Introduction

Do you need a thin, flexible, and sensitive heat flux sensor that can withstand high temperatures? FHF06 foil heat flux sensor offers all that and more. With a rated temperature range from -70 to +250 °C, FHF06 measures heat flux from conduction, radiation, and convection. In case you do not need the high temperature range, consider our **FHF05 series** heat flux sensors. If FHF05 series or FHF06 do not meet your specific requirements, explore our full range of **heat flux sensor** models for special applications.

This manual offers information about the sensor, the working principle and all you need to know for proper application.

FHF06 is a high-temperature foil heat flux sensor engineered for temperatures up to 250 °C. This capability is made possible by its all-polyimide design, without using any glues. Other members of the FHF family, such as the **FHF05 series** sensors, are rated for use up to 120 °C. Like all FHF sensors, FHF06 is thin, flexible, and versatile.

FHF06 measures heat flux (in W/m^2) either through the object in which it is incorporated or on which it is mounted. Each sensor contains a thermopile that measures the temperature difference across FHF06's flexible body, which directly translates to heat flux. An integrated Type T thermocouple provides additional temperature measurement. Both the thermopile and thermocouple are passive sensors and do not require external power.

Figure 01 Model FHF06 foil heat flux sensor with thermal spreaders: thin, flexible, and versatile.

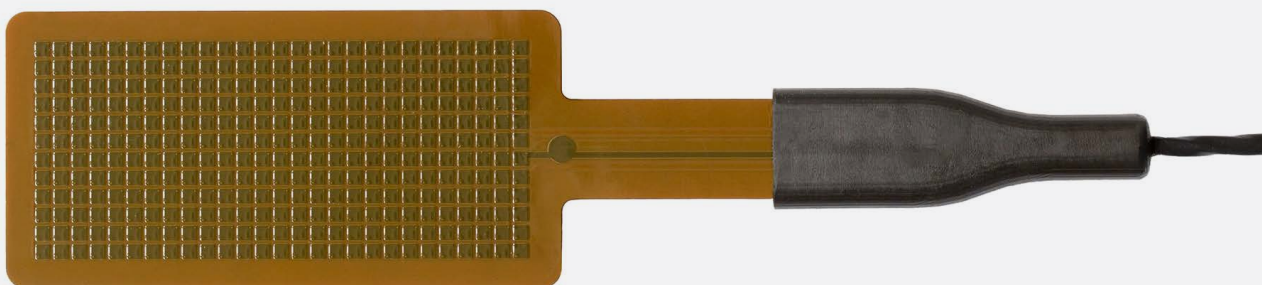

Multiple small thermal spreaders form a conductive layer covering the sensor, reducing the thermal conductivity dependence of the measurement. With these incorporated spreaders, the sensitivity of FHF06 is independent of the thermal properties of its environment.

In case you only work up to 120 °C, look at our **FHF05 sensors**.

Using FHF06 is easy. It connects directly to commonly used data logging systems. The heat flux (in W/m^2) is calculated by dividing FHF06's output, a small voltage, by the sensitivity, which is provided on its certificate.

Unique features and benefits

- high temperature resistance up to 250 °C continuous use
- flexible (bending radius $\geq 7.5 \times 10^{-3} \text{ m}$)
- low thermal resistance
- fast response time
- integrated Type T thermocouple
- robust design, including cable connection block for strain relief
- IP67 protection rating (essential for outdoor and humid environments)
- integrated thermal spreaders for low thermal conductivity dependence
- sensor foil only: may be used in vacuum environments

Robust and stable

FHF06 has proven to be very robust and stable. The instrument is equipped with a potted cable connection block that prevents moisture from entering and also serves as strain relief.



Figure 0.2 Model FHF06 high temperature foil heat flux sensor being used to monitor the performance of an oven. The sensor can be used for temperatures up to 250 °C.

Calibration

FHF06 calibration is traceable to international standards. The factory calibration method follows the recommended practice of ASTM C1130-21.

Working with heat flux sensors

When used under high-temperature conditions, the FHF06 sensitivity to heat flux may be different than stated on its certificate. Refer to the user manual for correcting this temperature dependence.

Installation

There are various ways to install a heat flux sensor. See our application note on [how to install a heat flux sensor](#) for more information.

Suitable electronics

The combined measurement of heat flux and temperature provides a complete picture of the system's thermal behavior. Heat flux sensors produce a small millivolt signal output and are often combined with thermocouples as part of a larger test or measuring system. We have several preferred solutions for amplification, data logging, and data visualisation. To learn more, view our application notes on [sensor amplification](#) or [FHF sensors with Hioki data loggers](#).

Options

- with 5 or 10 m cable lengths
- separate cable in 2, 5, or 10 m lengths
- sensor foil only (without wiring and without connection block)
- **LI19** hand-held read-out unit/data logger

NOTE: LI19 measures heat flux only.

See also

- **FHF05 series**: general-purpose heat flux sensor in five sizes with five sensitivities
- **FHF05SC series**: for a self-calibrating version of FHF05-50X50 and -85X85
- **HTR02 series** heater: for calibration and verification of the performance of FHF-type sensors
- Hukx offers a complete product range of high-quality heat flux sensors for any budget

1 Ordering and checking at delivery

1.1 Ordering FHF06

The standard configuration of FHF06 is FHF06-25X50-02, model 25X50 with 2 meters of cable. Common options are:

- change -02 to -05 or -10 meters for the respective cable length
- without cable, without cable connection block (sensor foil only)
- with a separate cable of 2, 5, or 10 meters cable length
- with **LI19** hand-held read-out unit/data logger;

NOTE: LI19 measures heat flux only, not temperature

- with a heater of the HTR02 series,
a foil heater for verification of performance

1.2 Included items

Arriving at the customer, the delivery should include:

- heat flux sensor FHF06 with cable of the length as ordered
- product certificate matching the instrument serial number



Figure 1.2.1 Model FHF06 with serial number and sensitivity shown at the end of the cable. Please note that the label is rated for temperatures up to 125 °C only.

1.3 Quick instrument check

A quick test of the instrument can be done by connecting it to a multimeter.

1. Check the sensor serial number on the label at the end of FHF06's cable against the sensitivity on the product certificate provided with the sensor.
2. Inspect the instrument for any damage.
3. Check the electrical resistance of the sensor between the red [+] and black [-] wires. Use a multimeter at the 1k Ω range. Measure the sensor resistance first with one polarity, then reverse the polarity. Take the average value. The typical resistance of the wiring is 0.3 Ω /m. Typical resistance should be the nominal sensor resistance of 200 Ω plus 0.6 Ω for the total resistance of two wires for each meter (back and forth). Infinite resistance indicates a broken circuit; zero or a lower than 1 Ω resistance indicates a short circuit.
4. Check the electrical resistance of the thermocouple between the brown [+] and white [-] wires. Use a multimeter at the 100 Ω range. Measure the thermocouple resistance first with one polarity, then reverse the polarity. Take the average value. The typical resistance of the copper wiring is 0.3 Ω /m, for the constantan wiring this is 6.5 Ω /m. Typical resistance should be the nominal thermocouple resistance of 2.5 Ω plus 6.8 Ω for the total resistance of the two wires of each meter (back and forth). Infinite resistance indicates a broken circuit; zero or a lower than 1 Ω resistance indicates a short circuit.
5. Check if the sensor reacts to heat: put the multimeter at its most sensitive range of DC voltage measurement, typically the 100×10^{-3} VDC range or lower. Expose the sensor to heat. Exposing the backside (the side without the dot) to heat should generate a positive signal between the red [+] and black [-] wires. Doing the same at the frontside (the side with the dot), reverses the sign of the output.

2 Instrument principle and theory

2.1 What a heat flux sensor is and how it works

FHF06 sensor's scientific name is heat flux transducer. We use the expression heat flux sensor, because this is more common. A heat flux sensor measures the heat flux density through the sensor itself. This quantity, expressed in W/m^2 , is usually called "heat flux".

FHF06 sensor users typically assume that the measured heat flux is representative of the undisturbed heat flux at the sensor's location. Users may also apply corrections based on scientific judgement.

The sensing element that generates a signal in FHF06s is a thermopile, which formally is a sensor. This thermopile measures the temperature difference across the sensor's polyimide—a plastic body. Working completely passively, the thermopile generates a small voltage that is a linear function of this temperature difference. The heat flux is proportional to the same temperature difference divided by the effective thermal conductivity of the heat flux sensor body.

Using an FHF06 heat flux sensor is easy. For read-out, the user only needs an accurate voltmeter that works in the millivolt range. To convert the measured voltage, U , to a heat flux Φ , the voltage must be divided by the sensitivity S , a constant supplied with each individual sensor.

$$\Phi = U/S \quad \text{(Formula 2.1)}$$

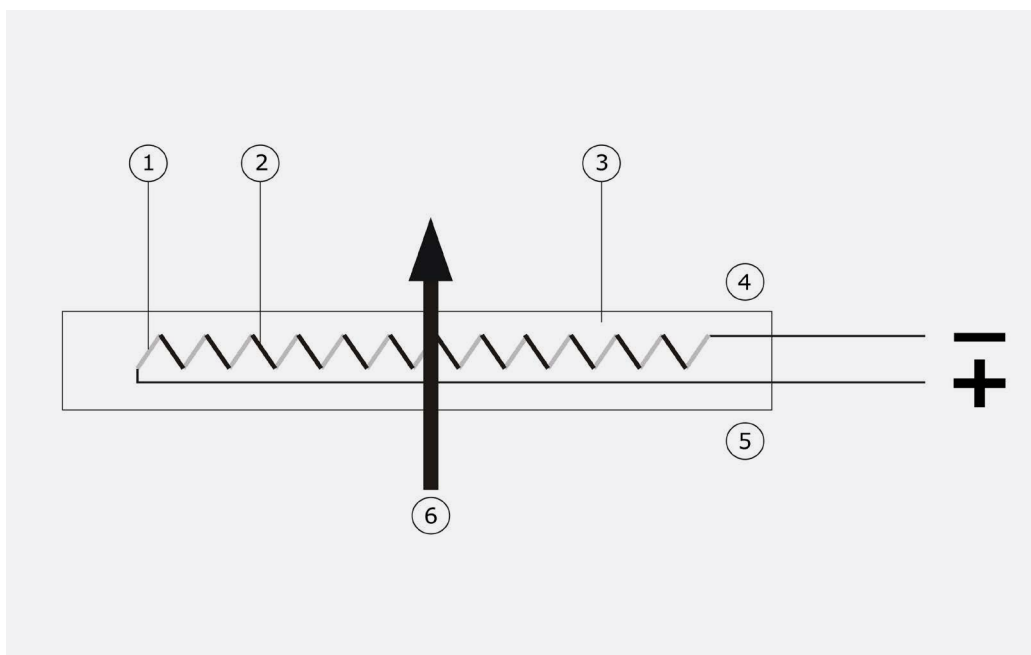

Figure 2.1.1 The general working principle of a heat flux sensor. The sensor inside FHF06 is a thermopile. A thermopile consists of a number of thermocouples, each consisting of two metal alloys (marked 1 and 2), electrically connected in series. A single thermocouple generates an output voltage that is proportional to the temperature difference between its hot and cold joints. Putting thermocouples in series amplifies the signal. In a heat flux sensor, the hot and cold joints are located at the opposite sensor surfaces (4 and 5). In a steady state, the heat flux (6) is a linear function of the temperature difference across the sensor and the average thermal conductivity of the sensor body (3). The thermopile generates a voltage output proportional to the heat flux through the sensor. The exact sensitivity of the sensor is determined at the manufacturer by calibration, and can be found on the product certificate that is supplied with each sensor.



Figure 2.1.2 Heat flux from the backside to the frontside generates a positive voltage output signal. The dot on the foil indicates the frontside.

FHF06 is designed in such a way, that heat flux from the backside to the frontside generates a positive voltage output signal. The dot on the foil indicates the frontside.

Unique features of FHF06 include high temperature resistance up to 250 °C, flexibility (bending radius $\geq 7.5 \times 10^{-3}$ m), low thermal resistance, a fast response time, IP67 protection class rating (essential for outdoor application and use under humid conditions), and the inclusion of thermal spreaders to reduce thermal conductivity dependence.

FHF06 is calibrated under the following reference conditions:

- conductive heat flux (as opposed to radiative or convective heat flux)
- homogeneous heat flux across the sensor and guard surface
- room temperature
- heat flux in the order of 300 W/m²
- mounted on aluminum heat sink

FHF06 has been calibrated using a well-conducting metal heat sink, representing a typical industrial application, at 20 °C and exposing it to a conductive heat flux. When used under conditions that differ from the calibration reference conditions, for example, at extremely high or low temperatures, or exposed to radiative flux, the FHF06 sensitivity to heat flux may be different than stated on the certificate. In such cases, the user may choose:

- Not to use the sensitivity and only perform relative measurements/monitor changes.
- Reproduce the calibration conditions by mounting the sensor on, or between metal foils.
- Design a dedicated calibration experiment, for example using a foil heater which generates a known heat flux.
- Correct the sensitivity for the temperature dependence.
See the appendix on correction of temperature dependence for more information.

The user should analyze his own experiment and make his own uncertainty evaluation. The FHF06 rated temperature range for continuous use is -70 to +250 °C. Please contact Hukx when measuring at -160 °C, see also the appendix on use at low temperatures.

You may look at a single heat flux sensor as a sensor composed of several smaller heat flux sensors. In case users want to enlarge sensor surface area or sensitivity, consider putting multiple sensors electrically in series. See the chapter on electrical connection 5.4.

2.2 Selecting a suitable FHF06 heat flux sensor model

FHF06 is available in one size only. The following text helps you check if you have the right sensor for your application and the right electronics. Selecting the right electronics-sensor combination helps reduce total system costs.

2.2.1 Step 1—familiarize yourself with heat flux measurement

Visit the [Hukx YouTube channel](#):

- [quick intro to heat flux](#) (3 min)
- [online course](#) (40 min)
- [separating radiation and convection](#) (2 min)

2.2.2 Step 2—verify if FHF06 is suitable for your application and environment

- Check if the heat flux is between -20 to $+20 \times 10^3 \text{ W/m}^2$.
(Higher flux levels? See the appendix on use at different flux levels.
Lower flux levels? See model [FHF05](#)).
- Verify that the rated temperature range is below $250 \text{ }^\circ\text{C}$.
(Only up to $120 \text{ }^\circ\text{C}$? See model [FHF05](#)).
- Verify other specifications chapters of this manual.

2.2.3 Step 3—look at electronics

Verify that your electronics are suitable:

- Estimate the output range of the heat flux sensor(s) in $[\times 10^{-6} \text{ V}]$ using the sensitivities in the specifications table: microvolt
output range = heat flux range in $[\text{W/m}^2] \times$ sensitivity in $[\times 10^{-6} \text{ V}/(\text{W/m}^2)]$.
- Check if your electronics accept analogue voltage input.
- Check if the microvolt voltage measurement accuracy of your instruments is better than 1% of the output range, to ensure electronics are not the limiting factor in measurement accuracy. If your electronics accuracy is insufficient, you may choose a larger sensor or put sensors in series to create a higher sensitivity.
- Make sure that your electronics accept type T thermocouples. If not, consider whether a temperature measurement is needed or if a separate temperature sensor can be added.

2.2.4 Step 4—ask Hukx to check your choices

- Ask for our input/suggestions. Send all information and specifications of your application to Hukx. This includes: purpose of the measurement, heat flux source, heat flux sink, expected heat flux and temperature ranges, electronic devices used, sketch of the setup indicating specifications and dimensions.
- Consider alternatives. The FHF sensors may not be the best option: We can supply many different sensor models optimized for a wide range of applications.

3 Specifications of FHF06

3.1 Specifications of FHF06

FHF06 measures the heat flux density through the surface of the sensor. This quantity, expressed in W/m^2 , is called heat flux. Using a thermopile sensor, FHF06 generates a small output voltage proportional to this flux. A type T thermocouple is included for temperature measurement. No power supply is needed. FHF06 can only be used in combination with a suitable measurement system.

Table 3.1.1 Specifications of FHF06 (continued next pages).

FHF06 specifications	
sensor type	high temperature foil heat flux sensor
sensor type according to ASTM	heat flow sensor or heat flux transducer
measurand	heat flux
measurand in SI units	heat flux density in W/m^2
measurement range	$(-20 \text{ to } +20) \times 10^3 \text{ W/m}^2$ at heat sink temperature $20 \text{ }^\circ\text{C}$ see the appendix for detailed calculations
sensitivity	$5 \times 10^{-6} \text{ V/(W/m}^2)$
directional sensitivity	Heat flux from the backside to the frontside (side with the dot) generates a positive voltage output signal
asymmetry	< 2%
increased sensitivity and spatial coverage	Multiple sensors may be put electrically in series. The resulting sensitivity is the sum of the sensitivities of the individual sensors. The resulting measurement is representative for the heat flux over the area covered by the sensors and may also be representative for the area between the sensors.

expected voltage output	(-100 to +100) x 10 ⁻³ V Turning the sensor over from one side to the other will lead to a reversal of the sensor voltage output
measurement function/required programming	$\Phi = U/S$
required read-out	1 differential voltage channel or 1 single ended voltage channel, input resistance > 10 ⁶ Ω
optional read-out	1 temperature channel
rated load on wires	≤ 1.6 kg
rated bending radius	≥ 7.5 x 10 ⁻³ m
rated temperature range, continuous use	-70 to +250 °C for use to -200 °C, see the appendix
rated temperature range cable	-70 to +250 °C
rated temperature range connection block	-70 to +250 °C
rated temperature range, short intervals	to +250 °C
outgassing of sensor foil	low outgassing, 0.36 % total mass loss, 0.01 % collected volatile condensable material (CVCM) as per NASA-JSC
temperature dependence	< 0.2 %/°C (see also the chapter on correction for temperature dependence)
non-linearity	< 5 % (0 to 10 x 10 ³ W/m ²)
solar absorption coefficient	0.85 (indication only)
thermal conductivity dependence	negligible, < 3 %/(W/(m·K)) for environments from 270 to 0.3 W/(m·K)
sensor length and width	(25 x 50) x 10 ⁻³ m
sensing area	8.9 x 10 ⁻⁴ m ²
sensing area length and width	(20 x 44.5) x 10 ⁻³ m
passive guard area	3.6 x 10 ⁻⁴ m ²
guard width to thickness ratio	6.25

sensor thickness	0.38 x 10 ⁻³ m
sensor thermal resistance	12 x 10 ⁻⁴ K/(W/m ²)
sensor thermal conductivity	0.31 W/(m·K)
response time (95 %)	3 s
sensor resistance (nominal)	200 Ω
required sensor power	zero (passive sensor)
temperature sensor	type T thermocouple
temperature sensor accuracy	Standard grade type T according to ASTM E230 (IEC 60584 Class 2) ± 1.0 °C or 0.0075 × T (whichever is greater) if the temperatures of the sensor foil and cable connection block are the same. See the appendix for other conditions.
standard cable length	2 m
optional cable length	0, 5 or 10 m
wiring	3 x copper and 1 x constantan wire, AWG 28, solid core, bundled with a MFA sheath
cable diameter	2 x 10 ⁻³ m
marking	dot on foil indicating the frontside of the heat flux sensor 1 x label at the end of FHF06's cable, showing serial number and sensitivity
IP protection class	IP67
rated operating relative humidity range	0 to 100 %
long-term exposure to water	See the appendix on long-term use under condensing, wet and underwater conditions.
rated operating pressure range	sensor foil only: 25 bar uniform pressure see the appendix on use under pressure sensor foil only: may be used in vacuum see the appendix on use under vacuum

gross weight including 2 m cable	approx. 0.5 kg
net weight including 2 m cable	approx. 0.5 kg
color	The color of the flex foil can vary from brown to gray-brown.

Installation and use

typical conditions of use	In experiments, in measurements in laboratory and industrial environments. Exposed to heat fluxes for periods of several minutes to several years. Connected to user-supplied data acquisition equipment. Regular inspection of the sensor. Continuous monitoring of sensor temperature. No special requirements for immunity, emission, chemical resistance. Sensor foil can be used in vacuum.
recommended number of sensors	2 or more per measurement location
installation	see the chapter on installation for recommendations
bending	see the chapter on installation on curved surfaces
cable extension	see the appendix on cable extension, or order sensors with longer cable length
sensor foil installation	see the appendix on installation of FHF06 foils

Calibration

calibration traceability	to SI units
product certificate	included (showing calibration result and traceability)
calibration method	method HFPC, according to ASTM C1130-21
calibration hierarchy	from SI through international standards and through an internal mathematical procedure
calibration uncertainty	$< \pm 5\%$ ($k = 2$)
recommended recalibration interval	2 years
calibration reference conditions	20 °C, heat flux of 300 W/m ² , mounted on aluminum heat sink, thermal conductivity of the surrounding environment 0.0 W/(m·K)

validity of calibration

Based on experience the instrument sensitivity will not change during storage.
During use the instrument "non-stability" specification is applicable. When used under conditions that differ from the calibration reference conditions, the FHF06 sensitivity to heat flux may be different than stated on its certificate. See the chapter on instrument principle for suggested solutions.

field validation

Is possible by comparison to a calibration reference sensor. Usually mounted side by side, alternatively on top of the field sensor. Preferably reference and field sensor of the same model and brand. Typical duration of test > 24 h
see the paragraph on validation and calibration

Measurement accuracy

uncertainty of the measurement

Statements about the overall measurement uncertainty can only be made on an individual basis.

Versions/options

with longer cable length

option code = cable length in meters

without cable, without connection block

calibrated FHF06 sensor foil
to be soldered/connected by the user
see appendix for more information

Accessories

hand-held read-out unit

L19 handheld read-out unit/data logger
NOTE: L19 does not measure temperature, only heat flux

separate foil heater

HTR02-50X50 general-purpose heater,
that can be used for test and calibration purposes
see HTR02 heater manual for more information

separate cable

cable with 3 x copper and 1 x constantan wire,
AWG 28, solid core, bundled with an PFA sheath
available in 2, 5 or 10 m length

3.2 Dimensions of FHF06 series

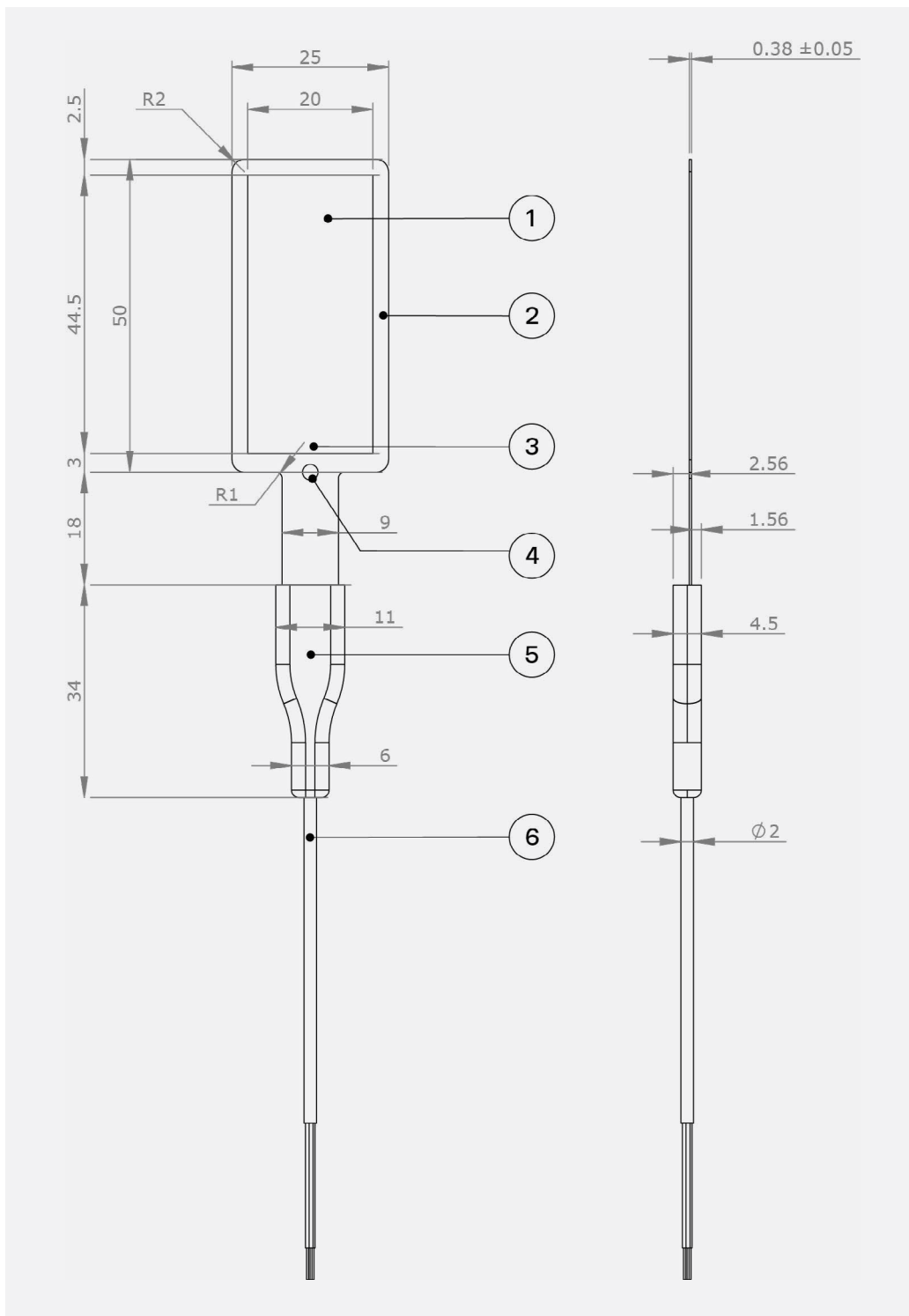

Figure 3.2.1 Model FHF06 with dimensions in $\times 10^{-3}$ m.

1. sensing area with thermal spreaders
2. passive guard
3. Type T thermocouple
4. dot indicating frontside
5. potted cable connection block for strain relief
6. cable, standard length $C = 2$ m

4 Standards and recommended practices for use

FHF06 should be used in accordance with recommended practices.

There are no ISO, ASTM or IEC standards with recommended practices for use of heat flux sensors like FHF06.

4.1 Heat flux measurement in industry

FHF06 is often used to measure on industrial walls and metal surfaces, estimating the installation's energy balance and the thermal transmission of walls. Typically, the total measuring system consists of multiple heat flux and temperature sensors. In many cases, heat flux sensors are used for trend monitoring. In such cases, reproducibility is more important than absolute measurement accuracy.



Figure 4.11 Example of model FHF06 high temperature foil heat flux sensor being installed for measurement on a car exhaust. FHF06 is flexible and can be easily mounted on a curved surface like a pipe or tube.

5 Installation of FHF06

Before performing a measurement, and permanently installing a heat flux sensor, we recommend to extensively test the heat flux sensor and the entire measuring system.

For example:

- confirm the functionality and measurement accuracy of the temperature sensor in a temperature bath
- confirm the functionality and accuracy of the heat flux measurement in a separate experiment, for example using electrical heaters such as those of the HTR series and a heatsink

In such experiments you may select a temperature and a heat flux sensor to serve as references and determine deviations relative to this reference.

5.1 Why to avoid air gaps

The thermal conductivity of air is in the order of $0.02 \text{ W/(m}\cdot\text{K)}$. Therefore, even small air gaps are significant thermal resistances. The thermal conductivity of plastic or thermal paste is in the order of $0.2 \text{ W/(m}\cdot\text{K)}$, so for the same thickness, thermal resistance is a factor 10 lower. Take for example a $0.05 \times 10^{-3} \text{ m}$, air gap. This has a thermal resistance of $20 \times 10^{-4} \text{ K/(W/m}^2)$. This may be compared to around $10 \times 10^{-4} \text{ K/(W/m}^2)$ for FHF sensors, so a small air gap produces an increase of thermal resistance of respectively 200 % for FHF. Using a filler of $0.05 \times 10^{-3} \text{ m}$, with a thermal conductivity around 10 times higher than that of air, the thermal resistance is reduced to $2.5 \times 10^{-4} \text{ K/(W/m}^2)$. The contribution of the thermal resistance reduces to about 20 %.

From this example you can also see that it is not necessary to use high-thermal conductivity tapes. Using a thin normal tape is enough.

An air gap may not only lead to a higher thermal resistance for conductive heat, but also to an entirely different radiation balance. An air gap is a "resistance" (a radiation screen) for radiative transfer. If it is filled-up, it is no resistance any longer. Watch out in case radiative (far infrared) heat flux is significant. In that case, the presence of an air gap may be the dominant source of errors, because a sensor with an air gap acts as a radiation shield, reducing local radiative transfer by a theoretical maximum of 50 %.

5.2 Site selection and installation

See also our application note on [how to install a heat flux sensor](#).

Table 5.2.1 Recommendations for installation of FHF06 heat flux sensor (continued on next page).

location	<p>Choose a location that is representative of the process that is analyzed.</p> <p>If possible, avoid exposure to sun, rain, etc.</p> <p>Do not expose to drafts and lateral heat fluxes .</p> <p>Do not mount in the vicinity of thermal bridges, cracks, heating or cooling devices and fans.</p>
performing a representative measurement/ recommended number of sensors	<p>We recommend using > 2 sensors per measurement location. This redundancy also improves the assessment of the measurement accuracy.</p>
mounting	<p>When mounting a FHF06, keep the directional sensitivity in mind; heat flux from the backside to the frontside (side with dot) generates a positive voltage output signal.</p> <p>Please note that the label at the end of the cable showing serial number and sensitivity can handle only temperatures up to 125 °C, see Figure 5.1.2.</p> <p>To achieve the highest accuracy temperature measurement, fix the cable connection block to the object of interest, so that the temperature of the connection block remains as close as possible to that of the heat flux sensor (see appendix on accuracy of the temperature measurement).</p>
surface cleaning and levelling	<p>Create a clean and smooth surface of at least the outer dimensions of the sensor in use.</p>
mechanical mounting: avoiding strain on the sensor to cable transition	<p>During installation as well as operation, the user should provide proper strain relief on the cable so that the cable connection block is not exposed to significant force.</p> <p>First, install the sensor by providing strain relief on the connection block and after that install the cable including additional strain relief.</p>
short-term installation	<p>To avoid air gaps, we recommend thermal paste or glycerol for short-term installation.</p> <p>Use tape to mount the sensor on the surface. If possible, tape only over the passive guard area (surrounding the sensing area). See Figure 5.2.1</p> <p>Use tape to mount the cable connection block of the sensor. Usually, the cables are mounted with an additional strain relief, for example using a cable tie mount as in Figure 5.2.1.</p>

permanent installation

For long-term installation, fill up the space between sensor and object with silicone construction sealant, silicone glue or silicone adhesive that can be bought at construction depots.

We discourage the use of thermal paste for permanent installation because it tends to dry out. Silicone glue is more stable and reliable.

signal amplification

See the paragraph on electrical connection.

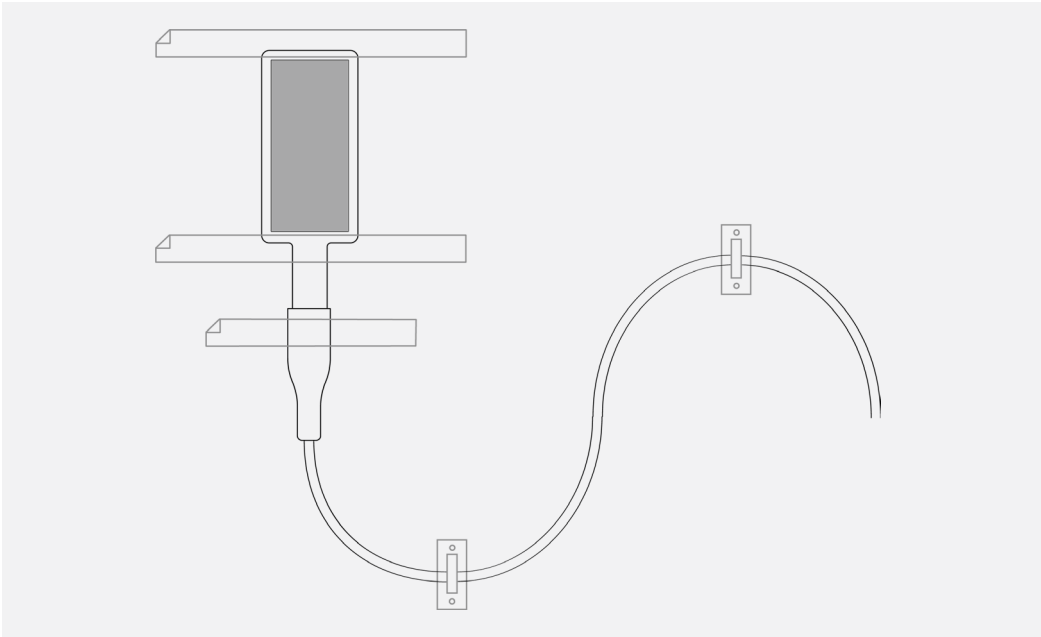

Figure 5.2.1 Installation of model FHF06 using tape to fixate the sensor and the connection block. Extra strain relief on the cable is provided using cable tie mounts equipped with double-sided tape as an adhesive. As indicated in Table 5.1.1, tapes used for mounting the sensor are preferably taped over the passive guard area and not on the sensing area (the latter indicated by grey shading in Figure 5.1.1). Please note the dot is visible in this image; this indicates that we are viewing the frontside and that the other side, the backside, is attached to the object on which the sensor is mounted, as explained in Chapter 2.

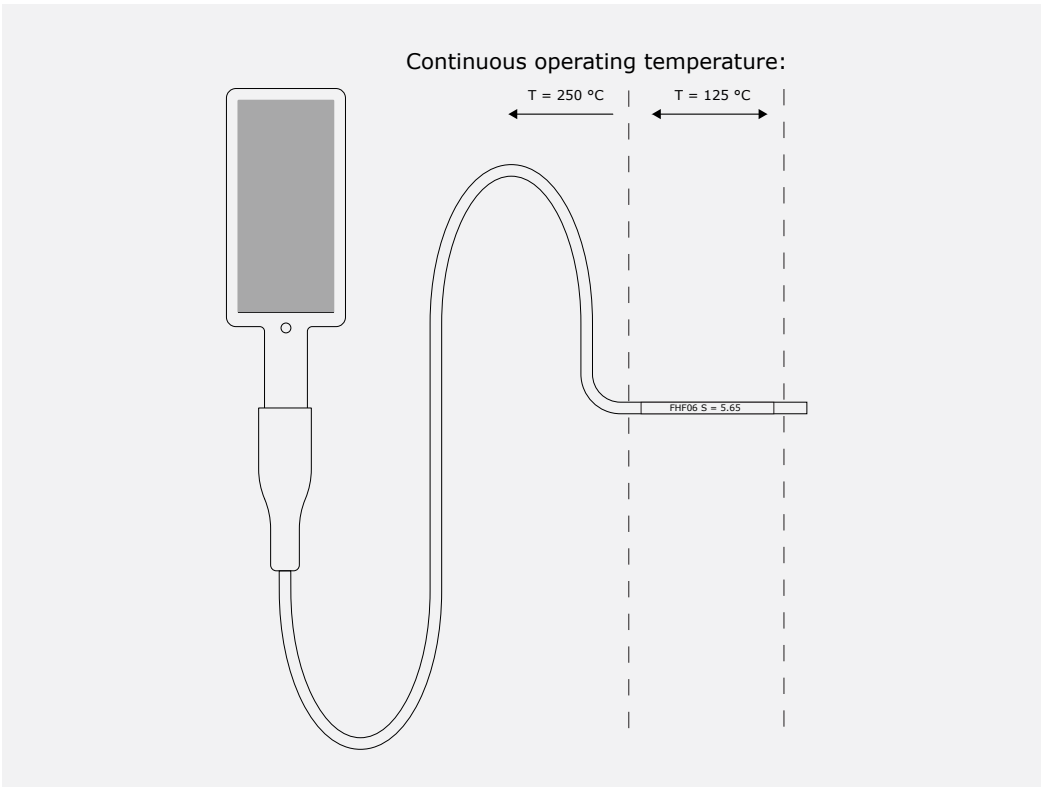

Figure 5.2.2 The label at the end of the cable showing serial number and sensitivity can handle only temperatures up to 125 °C. The sensor, cable and connection block have a continuous operating temperature up to 250 °C.

Table 5.2.2 Options for mounting heat flux sensors. Materials may act to position the sensor, but also to fill up airgaps.

Product	Duration	Temperature range	Functionality	Comments
[type]	[time]	[°C]	[description]	[description]
single sided tape	temporary or permanent	-260 to 150	positioning only	positioning only, use with other fillers such as thermal paste TESA 51408 orange masking tape most commercially available Kapton tapes are suitable
silicone glue	permanent potentially removable	-45 to 200	positioning and gap filling	most commercially available silicone glues are suitable DOWSIL 3145 silicone sealant Before silicone hardens the sensor is typically held in position using a tape
high temperature epoxies	permanent not removable	to 300	positioning and gap filling	Duralco 4460 adhesive epoxy
glycerin	short term	to 120	gap filling only	Filler only for quick experiments; glycerin can be obtained at the local pharmacy. It is safe to use and easily dissolves in water.
toothpaste	short-term (days)	40	gap filling only	filler only, use with other positioning such as single-sided tape water-based most commercially available toothpastes are suitable
thermal paste	weeks	to 177	gap filling only	filler only, use with other positioning such as single-sided tape silicone oil-based DOW CORNING heat sink compound 340

5.3 Installation on curved surfaces

The flexibility of the FHF06 sensor foil makes it perfectly suitable to be installed on singly curved surfaces. The sensor can be bent around any axis.

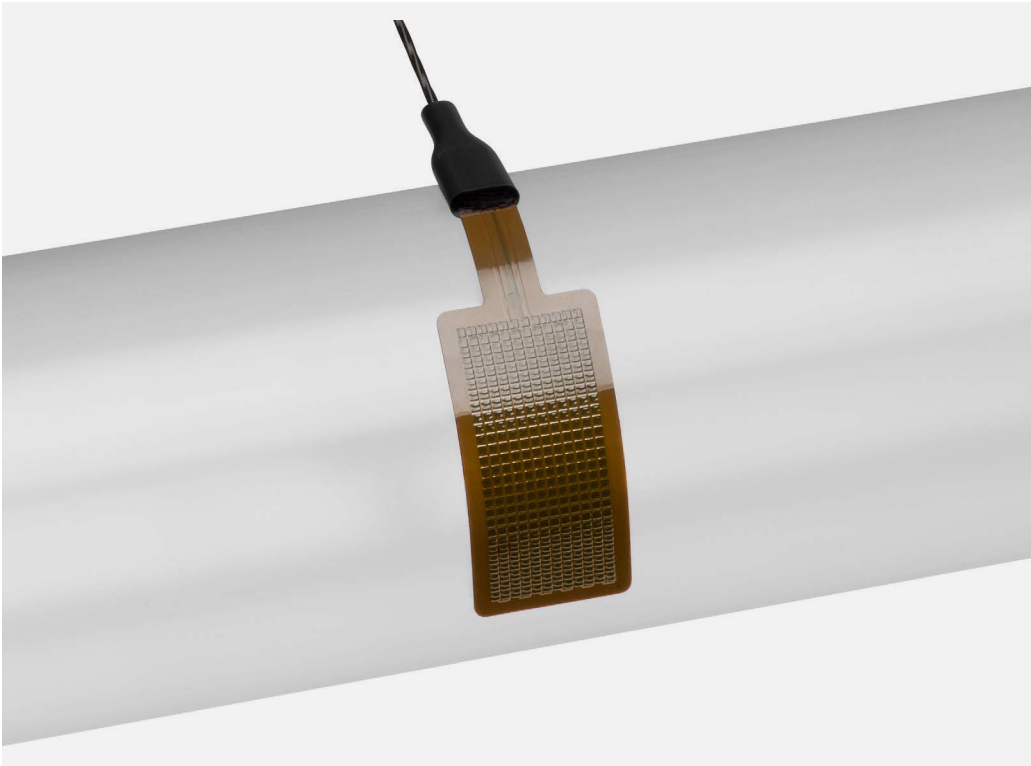

Figure 5.3.1 Bending of model FHF06 foil heat flux sensor, in this image on a pipe.

When measuring on curved surfaces, the same recommendations of the previous chapter apply, except that the use of thermal paste is recommended over glycerol. For installation on curved surfaces, it is usually not achievable to tape only over the passive guard area. Use sufficient tape to make sure the sensor remains fixed and in good thermal contact with the curved surface. Avoid air gaps. Tape can be used over the sensing area when necessary.

Table 5.3.1 Extra recommendations for installation of FHF06 series foil heat flux sensors on curved surfaces.

bending	sensor foil can be bent in all directions
rated bending radius	$\geq 7.5 \times 10^{-3} \text{ m}$
effect on sensitivity	no significant influence on sensitivity

5.4 Electrical connection

5.4.1 Electrical diagram

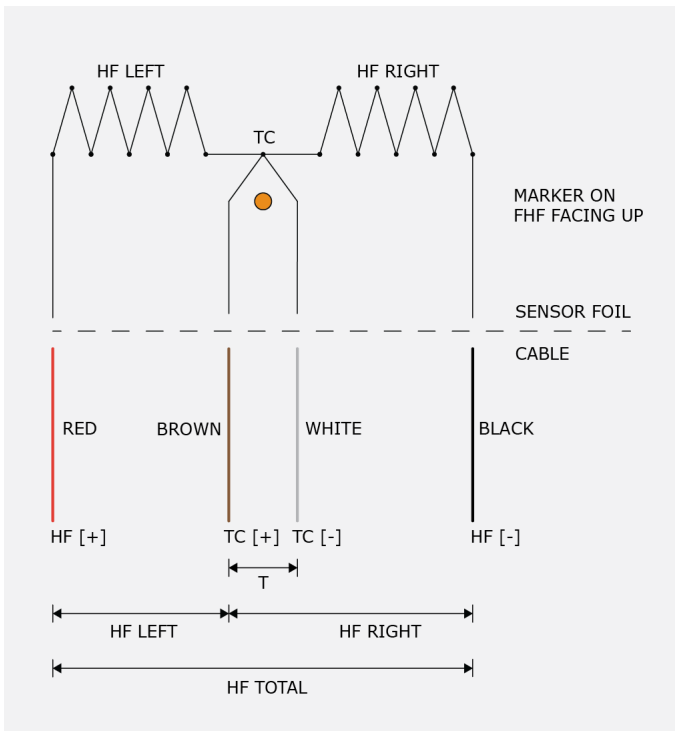

Figure 5.4.1 Electrical diagram of sensor foil and cable of FHF sensors.

5.4.2 Normal connection

A heat flux sensor should be connected to a measurement system, typically a so-called data logger. FHF06's heat flux and temperature sensor are passive and do not need any power. Cables and wires may act as a source of distortion, by picking up capacitive noise. We recommend keeping the distance between a data logger or amplifier and the sensor as short as possible. For cable extension, see the appendix on this subject.

Table 5.4.2.1 The electrical connection of FHF06.

wire		measurement system
Red	heat flux signal [+]	voltage input [+]
Black	heat flux signal [-]	voltage input [-]
Brown	thermocouple type T [+]	thermocouple input [+]
White	thermocouple type T [-]	thermocouple input [-]

The sensor serial number and sensitivity are shown on the FHF06's product certificate and at the end of FHF06's cable.

NOTICE

Putting more than 24 Volt across the sensor wiring can lead to permanent damage to the sensor.

NOTICE

The heat flux sensor and thermocouple are electrically connected inside the FHF sensor foil. In the hardware used for measurement of the sensor output, do not electrically short-circuit (part of) the heat flux signal and thermocouple; this will reduce signal output by 50 %.

5.4.3 Increasing sensitivity and spatial coverage—connecting multiple sensors in series

Multiple heat flux sensors may be electrically connected in series. By making a connection the resulting output becomes the sum of the output of the individual sensors. The sensitivity then is the sum of the sensitivities of the individual sensors. The resulting measurement is then representative of the heat flux over the area covered by the sensors and may also be representative for the area between the sensors.

Below are the equations in case two sensors are used. If needed, more than two sensors may be put in series, again increasing the sensitivity.

$$\Phi = U/(S_1 + S_2) \quad (\text{Formula 5.4.3.1})$$

and

$$U = U_1 + U_2 \quad (\text{Formula 5.4.3.2})$$

Table 5.4.3.1 The electrical connection of two FHF06 sensors, 1 and 2, in series. In such case, the sensitivity is the sum of the two sensitivities of the individual sensors. More sensors may be added in a similar manner.

sensor	wire		measurement system
1	Red	signal 1 [+]	voltage input [+]
1	Black	signal 1 [-]	connect to signal 2 [+]
1	Brown	thermocouple type T [+]	
1	White	thermocouple type T [-]	
2	Red	signal 2 [+]	connect to signal 1 [-]
2	Black	signal 2 [-]	voltage input [-] or ground
2	Brown	thermocouple type T [+]	
2	White	thermocouple type T [-]	

The sensor serial number and sensitivity are shown on the FHF06 product certificate and at the end of FHF06's cable.

For the temperature measurement, users may consider

- to read out one thermocouple only
- to put several thermocouples in parallel (so feeding several thermocouple wires to one input channel). The temperature reading will then be the weighted average of the signals. Weighting is by $1/R$ with R the electrical resistance. In case cables are equally long, with the same conductor diameters, this will result in a normal average.

5.4.4 Connection to read out half signals

See the figure below: heat flux sensors in FHF06 can be connected to read out only the heat flux through the left half of the sensing area or the heat flux through the right half of the sensing area.

This feature may be used for quality assurance purposes; if the sensor is correctly installed, a constant percentage (usually close to 50 %) of the signal will be generated by the left – and right. If the two 50 % signals are read out, the sensor's brown wire is typically connected to a thermocouple input, and from there, two copper wires may be used to connect the same signal to the two 50 % heat flux millivolt read-out inputs.

NOTE: in case the user works with voltage measurements in which the [-] is connected to ground, use the 100 % and "right" 50 % signals only, and do not use the "left" configuration. These then share the same ground as the heat flux sensor [-]. Connecting the "left" as well, would create a short-circuit over the right signal, so that only the left signal is measured.

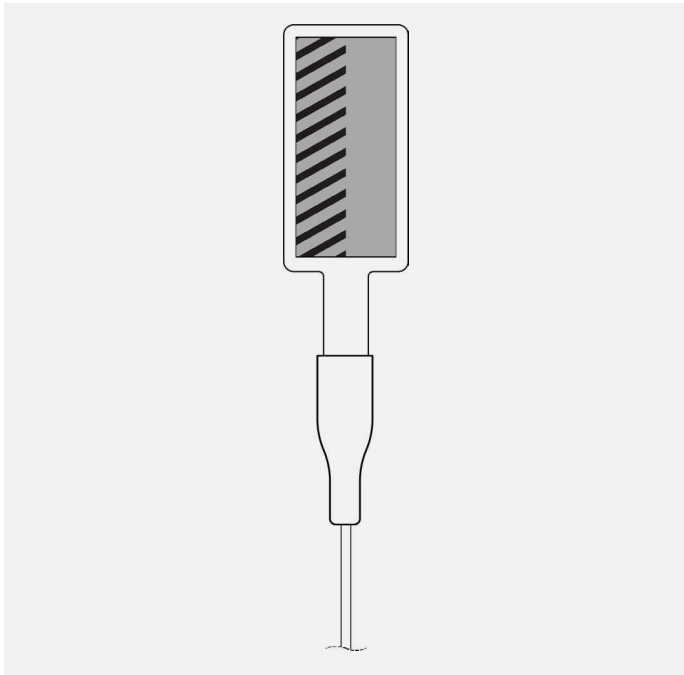

Figure 5.4.4.1 Model FHF06 with left half indicated by diagonal lines.

Table 5.4.4.1 The electrical connection of FHF06 for 100 % signal.

wire		measurement system
Red	heat flux signal [+]	voltage input [+]
Black	heat flux signal [-]	voltage input [-] or ground
Brown	thermocouple type T [+]	
White	thermocouple type T [-]	

Table 5.4.4.2 The electrical connection of FHF06 for left 50 % signal.

wire		measurement system
Red	heat flux signal [+]	voltage input [+]
Black	heat flux signal [-]	
Brown	thermocouple type T [+]	voltage input [-] or ground
White	thermocouple type T [-]	

Table 5.4.4.3 The electrical connection of FHF06 for right 50 % signal.

wire		measurement system
Red	heat flux signal [+]	
Black	heat flux signal [-]	voltage input [-] or ground
Brown	thermocouple type T [+]	voltage input [+]
White	thermocouple type T [-]	

5.5 Requirements for data acquisition/amplification

The selection and programming of data loggers is the responsibility of the user. Please contact the supplier of the data acquisition and amplification equipment to see if directions for use with the FHF06 sensors are available. In case a program for similar sensors is available, this can be used. All FHF06's can be treated in the same way as other heat flux sensors and (analogue) thermopile pyranometers.

NOTICE

Do not use "open circuit detection" when measuring the heat flux sensor and thermocouple output signals.

Table 5.5.1 Requirements for data acquisition and amplification equipment for FHF06 sensors in the standard configuration.

capability to measure small voltage signals	<p>preferably: $< 5 \times 10^{-6}$ V uncertainty minimum requirement: 20×10^{-6} V uncertainty (valid for the entire expected temperature range of the acquisition/amplification equipment)</p> <p>Select your data logger voltage range setting carefully, based on the heat flux sensor sensitivity and the expected heat flux level. Setting your data logger voltage range too high may lead to a low resolution and large offsets, not allowing you to detect changes at low heat flux levels. Setting your data logger voltage range too low may lead to over ranging, leading to a cap in measured heat flux level or temperature, or leading to data logger measurement errors.</p>
capability for the data logger or the software	To store data, and to perform division by the sensitivity to calculate the heat flux $\Phi = U/S$.
capability to measure thermocouple type T	preferably: $< \pm 3$ °C uncertainty
data acquisition input resistance	$> 1 \times 10^6 \Omega$
open circuit detection (WARNING)	<p>Open-circuit detection should not be used, unless this is done separately from the normal measurement by more than 5 times the sensor response time and with a small current only. Thermopile sensors are sensitive to the current that is used during open circuit detection. The current will generate heat, which is measured and will appear as a temporary offset.</p>

6 Maintenance and trouble shooting

6.1 Recommended maintenance and quality assurance

FHF06 measures reliably at a low level of maintenance. Unreliable measurement results are detected by scientific judgement, for example by looking for unreasonably large or small measured values. The preferred way to obtain a reliable measurement is a regular critical review of the measured data, preferably checking against other measurements.

Table 6.1.1 Recommended maintenance of FHF06 sensors. If possible, the data analysis is done daily.

Minimum recommended heat flux sensor maintenance			
	interval	subject	action
1	1 week	data analysis	<p>Compare measured data to the maximum possible or maximum expected heat flux and to other measurements, for example from redundant instruments.</p> <p>Look for any patterns and events that deviate from what is normal or expected.</p> <p>Set acceptance intervals for temperature and heat flux and compare measured data to these acceptance intervals.</p>
2	6 months	inspection	<p>Inspect sensor for wear, cable and wire condition, clamping of conductors at the data acquisition.</p> <p>Inspect sensor mounting.</p> <p>Inspect location of installation.</p> <p>Look for repeating (day–night, seasonal) patterns in measurement data.</p> <p>Try to explain these patterns.</p>
3	2 years	validation and recalibration	<p>Validation by comparison to a calibration reference sensor in the field, see the following paragraph about validation and calibration.</p> <p>Recalibration by the sensor manufacturer.</p>
4	2 years	lifetime assessment	<p>Judge if the instrument will be reliable for another 2 years, or if it should be replaced.</p>

6.2 Trouble shooting

Table 6.2.1 Trouble shooting for FHF sensors. (continued on the next page).

general

Inspect the sensor for any damage. Inspect the quality of mounting/installation. Inspect if the wires are properly attached to the data logger.

Check the condition of the cable and wires.

Check the data logger program, in particular if the right sensitivity is entered.

FHF sensor sensitivity and serial number are shown on the product certificate and at the end of the FHF's cable.

Check the electrical resistance of the sensor between all wires.

In many cases, this can be done on the screws of the clamps of the signal wires. In other cases, it is necessary to disconnect signal wires from the data acquisition.

See the following tables for the nominal electrical resistances per wire combination.

Measure resistances first with one polarity, then reverse the polarity.

Actual resistance values may vary from one sensor to the other sensor and with cable length. The typical resistance of the copper wiring (red, brown and black wires) is $0.3 \Omega/m$, for the constantan wiring (white wire) this is $6.5 \Omega/m$. Infinite resistance indicates a broken circuit; zero or a lower than 1Ω resistance indicates a short circuit.

the heat flux sensor does not give any signal

Check if the sensor reacts to heat: put the multimeter at its most sensitive range of DC voltage measurement, typically the 100×10^{-3} VDC range or lower. Expose the sensor to heat. Exposing the backside (the side without the dot) to heat should generate a positive signal between the red [+] and black [-] wires, doing the same at the frontside (the side with dot), the sign of the output reverses.

Check the data acquisition by replacing the sensor with a spare unit.

the heat flux sensor signal is unrealistically high or low

Check the wire condition.
Ensure that the wires clamp on the metal conductor and not (partly) on the plastic cladding of the wires.
Disconnect heat flux signal wires from data acquisition.
Check the data acquisition by applying a 1×10^{-6} V source to it in the 1×10^{-6} V range. Look at the measurement result. Check if it is as expected. Check the data acquisition by short circuiting the data acquisition input with a 10Ω resistor. Look at the output.
Check if the output is close to 0 W/m^2 . Check the data logger voltage range settings.

- A voltage range setting that is too high leads to a low signal resolution and high offsets.
- A voltage range setting that is too low can cause the sensor signal to cap at a maximum level of generate data logger errors.

Check for possible interference between the heat flux signal and thermocouple output. The heat flux signal and thermocouple are electrically connected inside the heat flux sensor.
An electrical short-circuit between (part of) the heat flux signal and thermocouple, which may occur if they are both grounded, can reduce heat flux signal output by 50 %.

- With the thermocouple wires connected, disconnect the heat flux signal wires from the data acquisition and observe the behavior of the thermocouple reading.
- With the heat signal wires connected, disconnect the thermocouple signal wires and observe the behavior of the heat flux signal.
- Make sure the thermocouple measurement and heat flux/voltage measurements have no open circuit detection. If this is activated, disable it.

the heat flux or temperature sensor signal shows unexpected variations

Check for the presence of strong sources of electromagnetic radiation (radar, radio).
Check the condition of the sensor wires.
Check if the wires are not moving during the measurement.
If available on your data logger, turn on 50 Hz or 60 Hz noise filtering.
Ground your data logger.

the temperature measurement shows unrealistic values

Check if the thermocouple type T is selected in the data logger program.
 Check if a correct reference temperature is selected in the program.
 Check the electrical resistance of the thermocouple between the brown [+] and white [-] wires. Use a multimeter at the 100 Ω range. Measure the thermocouple resistance first with one polarity, then reverse the polarity. Take the average value. The typical resistance of the copper wiring is 0.3 Ω/m, for the constantan wiring this is 6.5 Ω/m. Typical resistance should be the nominal thermocouple resistance of 2.5 Ω plus 6.8 Ω for the total resistance of the two wires of each meter (back and forth). Infinite resistance indicates a broken circuit; zero or a lower than 1 Ω resistance indicates a short circuit.
 Make sure the temperature of the connection block remains as close as possible to that of the heat flux sensor. See appendix on temperature measurement accuracy for more information.
 Check the program settings, signal range settings and sampling speed of your data logger. Please ask the data logger provider to comment on the data files. Do not use open circuit detection on your data logger. In FHF06 sensors the thermocouple is electrically connected to the heat flux sensor. Some older data loggers do not properly handle such electrical connections. Disconnect the heat flux signal wires from the data acquisition to see if this is the cause of the problem.
 Check the connection of the thermocouple wires to the data logger. Ensure that the wires clamp on the metal conductor and not (partly) on the plastic cladding of the wires.
 Do not ground the thermocouple [-]. Only heat flux [-] should be connected to ground if needed. If the [-] minus signals of both the heat flux and the temperature are connected to ground, the heat flux sensor is partly, 50 %, short-circuited and the signal will be reduced by around 50 %.
 Make sure that the sensor does not pick up electrical noise by external sources (e.g., heavy machinery like heaters or air conditioners blowing hot or cold air over the sensor).

Table 6.2.2 Indicative electrical resistances between wires for FHF06 with standard cable length.

	Red	Black	Brown	White
Red	x	200 Ω	100 Ω	115 Ω
Black		x	100 Ω	155 Ω
Brown			x	15 Ω
White				x

6.3 Validation and calibration

The recommended calibration interval of heat flux sensors is 2 years.
Recalibration of field heat flux sensors is ideally done by the sensor manufacturer.

On-site field validation—that is, making sure the sensor is fit for purpose—is possible by comparison to a calibration reference sensor, which is usually mounted side by side or alternatively on top of the field sensor.

Hukx's main recommendations for field validations are:

1. to compare to a calibration reference of the same brand and type as the field sensor
2. to connect both to the same electronics so that electronics errors (also offsets) are eliminated
3. to mount all sensors on the same platform, so that they have the same body temperature
4. typical duration of test: > 24 h
5. typical heat fluxes used for comparison: > 200 W/m²
6. to correct deviations of more than $\pm 20\%$.
Lower deviations should be interpreted as acceptable and should not lead to a revised sensitivity.

Users may also design their own validation or calibration experiment, for example using a well-characterized foil heater.

7 Appendices

7.1 Appendix on cable and cable extension

FHF06 is equipped with one cable containing four wires. Three copper wires (red, brown and black) and one constantan wire (white). Standard cable length is 2 m. It is possible to order FHF06 with longer cable lengths or without any cable. A separate cable is available in 2, 5 or 10 m length.

Cables and wires may act as a source of distortion by picking up capacitive noise. Keep the distance between data logger or amplifier and sensor as short as possible.

In an electrically "quiet" environment, the FHF06 cable may be extended without problems. If done properly, the sensor signal, although small, will not significantly degrade because the sensor electrical resistance is very low (which results in good immunity to external sources) and because the voltage measurement circuit of the data logger has a high impedance. There is no current flowing, and there are no resistive losses.

Cable, wire and connection specifications are summarized below.

Table 7.1.1 Preferred specifications for cable and wire extension of FHF06.

cable and wiring	<p>Extend the red, brown and black wire with copper wires. Extend the white wire with constantan wire.</p> <p>For the constantan wire, use the right alloy for type T thermocouple measurements: $Cu_{55}Ni_{45}$</p> <p>For constantan and copper, use either Standard grade type T according to ASTM E230 or IEC 60584 Class 2. Use of thermocouple extension cables is permitted because for type T these have nominally the same composition as thermocouple cables.</p> <p>standard cable as supplied by Hukx: 3 x copper and 1 x constantan wire, AWG 28, solid core, bundled with a PFA sheath</p>
separate cable	<p>Available in 2, 5 or 10 m length. Longer cables may be offered as a "special" order.</p>
extension sealing	<p>Make sure any connections are sealed against humidity ingress.</p>
conductor resistance	<p>< 0.3 Ω/m (copper wire)</p>
cable outer diameter	<p>2×10^{-3} m</p>
length	<p>Cables and wires should be kept as short as possible, in any case, the total cable length should be less than 100 m.</p>
connection	<p>Either use gold-plated waterproof connectors, or solder the conductors and shield of the extension cables to those of the original sensor cable, and make a waterproof connection using heat-shrink tubing with hot-melt adhesive.</p> <p>When using connectors for extending the thermocouple wires, either use dedicated type T thermocouple connectors, or use connectors with a heavy metal housing in which no temperature differences occur, or put the connection in an enclosure in which no temperature differences occur.</p>

7.2 Appendix on installation of FHF06 sensor foil

FHF06 can optionally be ordered without cable and without cable connection block. It is also possible to order cables as separate parts. The user should ensure a good connection to the sensor by soldering wires. At high temperatures many connectors may not be used. Use of FFC/FPC ZIF connectors is not recommended.

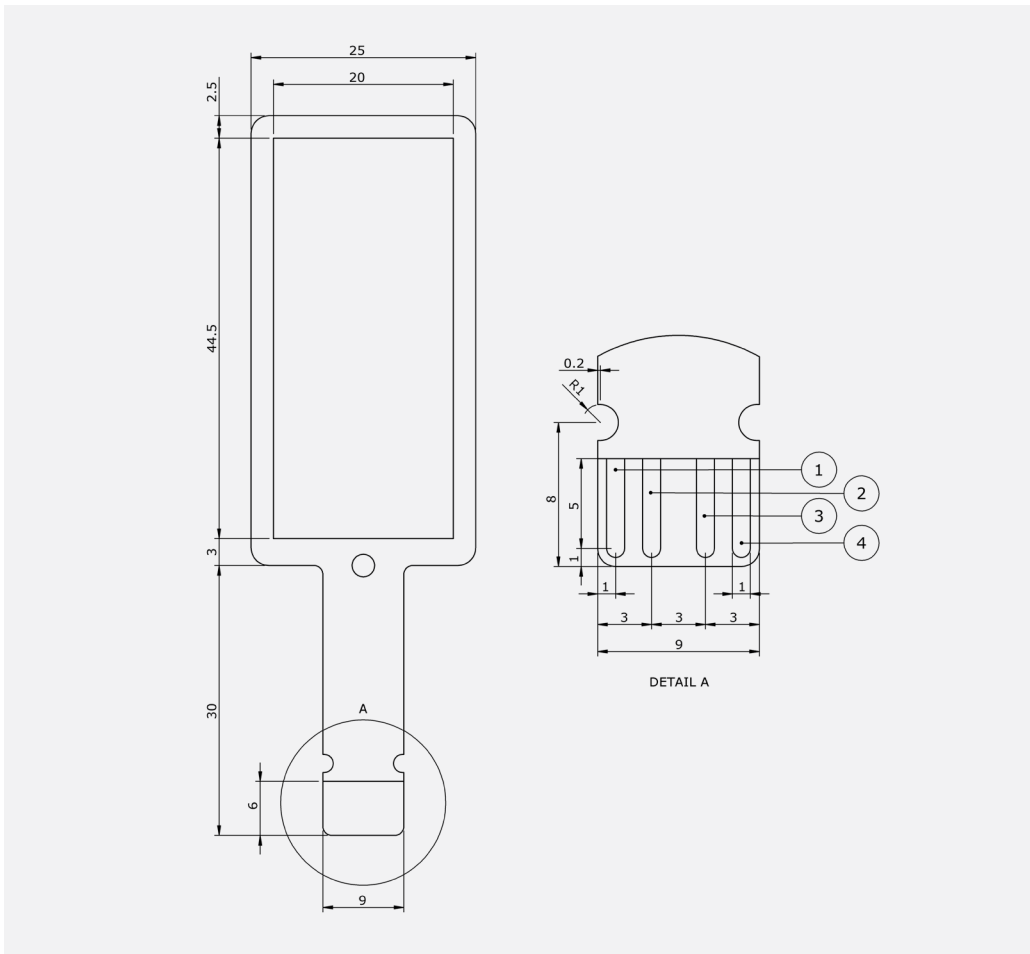

Table 7.2.1 Recommendations for soldering FHF06 sensor foils.

wire	Use insulated wires of preferably at least AWG28. It is possible to order a separate cable. Figure 7.2.1 shows which wire type to connect to which pad.
preparation	Clean the soldering pad before soldering with isopropyl alcohol (IPA).
solder material	Preferably use lead-free solder. Check the solder material on its temperature spec, commercially available solders with tin have a melting temperature of around 220 °C. We recommend a solder with gold.
soldering temperature	Use a soldering temperature of max 350 °C.
contact time	as short as possible (± 2 seconds)
surface	Place the sensor with soldering pad on a well-insulated surface.
strain relief	Add additional strain relief on the solder connections, for example by potting the connection with epoxy. Check the epoxy on its temperature spec, not all epoxies are capable of handling this temperature.

NOTICE

Accidentally cross-connecting the wires with soldering material will short-circuit part of the sensor. The voltage output of heat flux sensor may go to 50 % of the full heat flux or to 0. The temperature sensor output may go to zero, and then measure panel temperature only.

NOTICE

Avoid long contact between sensor foil and soldering equipment.
Excess heat can damage the soldering contacts.

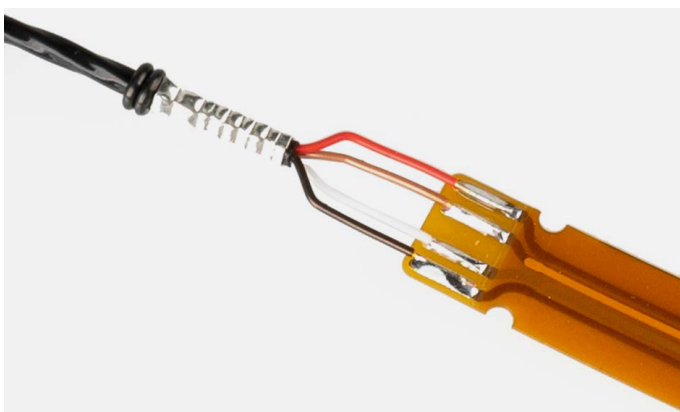

Figure 7.2.2 FHF06 sensor foil with soldered wires.

7.3 Appendix on standards for calibration

The standard ASTM C1130-21 *Standard Practice for Calibrating Thin Heat Flux Transducers* specifies in Chapter 6 that a guarded hot plate, a heat flowmeter, a hot box or a thin heater apparatus are all allowed. Hukx employs a thin heater apparatus, uses a linear function according to X1.1 and uses a nominal temperature of 20 °C, in accordance with X2.2. The Hukx HFPC method relies on a thin heater apparatus according to principles as described in Paragraph 4 of ASTM C1114-06, used in the single-sided mode of operation described in Paragraph 8.2 and in ASTM C1044-16.

ISO does not have a dedicated standard practice for heat flux sensor calibration. We follow the recommended practice of ASTM C1130-21.

Table 7.4.1 Heat flux sensor calibration according to ISO and ASTM.

Standards on instrument classification and calibration	
ISO standard	Equivalent ASTM standard
No dedicated heat flux calibration standard available.	ASTM C1130-21 <i>Standard Practice for Calibrating Thin Heat Flux Transducers</i>
	ASTM C 1114-06 <i>Standard Test Method for Steady-State Thermal Transmission Properties by Means of the Thin-Heater Apparatus</i>
	ASTM C1044-16 <i>Standard Practice for Using a Guarded-Hot-Plate Apparatus or Thin-Heater Apparatus in the Single-Sided Mode</i>

7.4 Appendix on calibration hierarchy

FHF06's factory calibration is traceable from SI through international standards and through an internal mathematical procedure that corrects for known errors. The formal traceability of the generated heat flux is through voltage and current to electrical power and electric power and through length to surface area.

The Hukx HFPC method follows the recommended practice of ASTM C1130-21. It relies on a thin heater apparatus according to principles as described in Paragraph 4 of ASTM C1114-06, in the single-sided mode of operation described in Paragraph 8.2 and in ASTM C1044-16. The method has been validated in a first-party conformity assessment, by comparison to calibrations in a guarded hot plate.

7.5 Appendix on correction for temperature dependence

The sensitivity of an FHF06 sensor depends on the temperature of the sensor. The temperature dependence of FHF06 is specified as $< 0.2 \text{ \%}/^{\circ}\text{C}$.

The calibration reference temperature is $20 \text{ }^{\circ}\text{C}$.

Users who measure at temperatures that deviate much from $20 \text{ }^{\circ}\text{C}$ or who measure over a wide range of temperatures may wish to correct for this temperature dependence.

To correct for the temperature dependence of the sensitivity, use the following measurement function:

$$\Phi = U/(S \cdot (1 + 0.002 \cdot (T - 20))) \quad (\text{Formula 7.5.1})$$

with Φ the heat flux in W/m^2 , U the FHF06 voltage output in V , S the sensitivity in $\text{V}/(\text{W}/\text{m}^2)$ at $20 \text{ }^{\circ}\text{C}$ and T the FHF06 temperature. The coefficient of 0.002 or $0.2 \text{ [\%}/\text{K}]$ is the best estimate Hukx currently has of the temperature dependence of sensitivity.

S is shown on the product certificate and at the end of FHF06's cable.

7.6 Appendix on measurement range for different temperatures

The measurement range of FHF06 is specified as $(-20 \text{ to } +20) \times 10^3 \text{ W/m}^2$ at $20 \text{ }^\circ\text{C}$ heat sink temperature. This is a very conservative specification.

In reality, the rated temperature for continuous use of $+250 \text{ }^\circ\text{C}$ is the limiting specification. The sensor temperature T in $^\circ\text{C}$ in a specific application depends on the heatsink temperature T_{heatsink} in $^\circ\text{C}$, the heat flux Φ in W/m^2 and the thermal resistance per unit area $R_{\text{thermal,A}}$ of the sensor in $\text{K}/(\text{W/m}^2)$.

$$T = T_{\text{heatsink}} + \Phi \cdot R_{\text{thermal,A}} \quad (\text{Formula 7.6.1})$$

This means the measurement range is lower for higher heat sink temperatures.

$$\Phi_{\text{maximum}} = (250 - T_{\text{heatsink}}) / R_{\text{thermal,A}} \quad (\text{Formula 7.6.2})$$

Table 7.6.1 shows measurement ranges for different heat sink temperatures. For applications where the sensor is not mounted on a heatsink, use the ambient temperature instead of heatsink temperature. NOTE: calculated values are based on thermal resistance of the sensor only. We assume that the thermal resistance of any glue layer is negligible.

Table 7.6.1 Measurement range for different heat sink temperatures.

heatsink temperature	measurement range
20 °C	$191 \times 10^3 \text{ W/m}^2$
40 °C	$175 \times 10^3 \text{ W/m}^2$
60 °C	$158 \times 10^3 \text{ W/m}^2$
80 °C	$141 \times 10^3 \text{ W/m}^2$
100 °C	$125 \times 10^3 \text{ W/m}^2$
120 °C	$108 \times 10^3 \text{ W/m}^2$
140 °C	$92 \times 10^3 \text{ W/m}^2$
160 °C	$75 \times 10^3 \text{ W/m}^2$
180 °C	$58 \times 10^3 \text{ W/m}^2$
200 °C	$41 \times 10^3 \text{ W/m}^2$
220 °C	$25 \times 10^3 \text{ W/m}^2$

7.7 Appendix on temperature measurement accuracy

All FHF's have an integrated thermocouple to measure temperature of the object under test. This thermocouple then performs a separate secondary measurement, in addition to the main heat flux measurement.

The uncertainty of the temperature measurement is the sum of the thermocouple measurement uncertainty (a sensor property) + the voltage measurement uncertainty of the electronics + the reference junction measurement uncertainty. The reference junction uncertainty and the uncertainty of the electronics should be part of the specifications of electronics. Please note the latter two are often ignored, because their contributions are typically small.

The FHF sensors are equipped with a cable containing thermocouple extension wires with an uncertainty specified as a type T thermocouple, IEC 60584-1:2013 class 2 or ASTM. They consist of a brown positive copper (Cu) wire and a negative white constantan ($\text{Cu}_{55}\text{Ni}_{45}$) wire. The contribution of thermocouple properties to the measurement uncertainty is $1\text{ }^\circ\text{C}$ or $\pm 0.75\%$ (whichever is larger) of the temperature differences between the cold joint T_2 and the sensor cold junction T_3 (see Figure 7.8.1).

For most applications we may assume that the cold junction uncertainty is negligible and that the temperatures T_1 and T_2 are identical.

The total expanded measurement uncertainty becomes, as stated in the specifications:

$$u_c(T) = (1\text{ }^\circ\text{C or } \pm 0.75\% \cdot \Delta T_2) \quad (\text{Formula 7.7.1})$$

However, if you want more detail: in the FHF sensor itself, the thermocouple junction (T_1) located at the object under test consists of copper and constantan traces that are extended from the connection block to the edge of the heat flux sensor sensitive area. These traces have slightly different Seebeck coefficients compared to normal thermocouple materials, which results in a higher measurement uncertainty of $\pm 5\%$ for temperature differences between T_1 and T_2 junctions.

The total expanded measurement uncertainty becomes:

$$u_c(T) = \text{cold junction uncertainty} \quad (\text{Formula 7.7.2}) \\ + 5\% \cdot \Delta T_1 + (1\text{ }^\circ\text{C or } \pm 0.75\% \cdot \Delta T_2)$$

It is clear from formula 7.7.2 that the accuracy is best, i.e., within the 2% range, if T_1 is kept close to the temperature T_2 , so that $\Delta T_1 = 0$. If the temperature measurement is critical, consider using a separate more accurate temperature sensor.

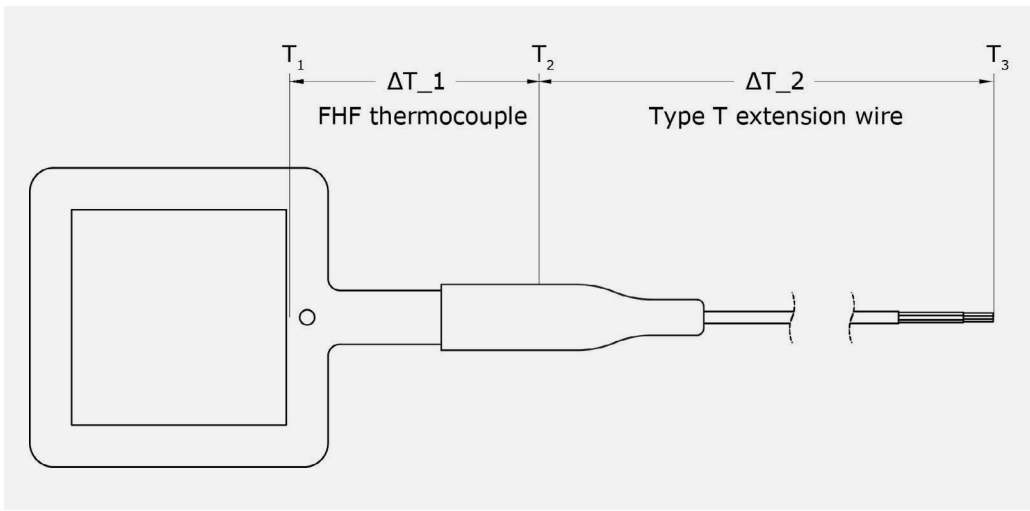

Figure 7.7.1 Model FHF with its thermocouple junctions. To minimize temperature measurement uncertainty, please make sure that ΔT_1 is close to zero.

7.8 Appendix on use of FHF sensor foils at low temperatures to $-200\text{ }^\circ\text{C}$

FHF users have employed the FHF05, FHF05SC and FHF06 sensor foils in cryogenic conditions, below the rated temperature of $-70\text{ }^\circ\text{C}$. Although use at lower temperatures is possible, Hukx does not specify the use down to $-200\text{ }^\circ\text{C}$ formally because the application of any sensors, not just these, at such temperatures is always high-risk. Use at a temperature lower than $-70\text{ }^\circ\text{C}$ is at the user's own risk.

NOTICE

At temperatures lower than the rated $-70\text{ }^\circ\text{C}$ FHF05, FHF05SC and FHF06 sensor foils may become stiffer and more brittle than in the rated temperature range. Use of these foils at these temperatures is possible, but at the user's own risk.

Practical experience at temperatures $< -70\text{ }^\circ\text{C}$:

- Hukx tested the FHF05 sensor foils at $-80\text{ }^\circ\text{C}$ and found no issues
- FHF05 sensor foils have been used in liquid natural gas ($-160\text{ }^\circ\text{C}$) conditions without problems

Directions for use at temperatures < -70 °C:

- Use the sensor foil only, not the cable connection block.
- The cable connection block between foil and cable is potted and not rated for lower temperatures than -70 °C. At lower temperatures use the sensor foil only, not the cable connection block.
- The FHF sensor foils are made using Kapton etched foil technology. The materials used are Kapton (polyimide), acrylic glue (not for FHF06) plus the metals of the sensor. This technology is generally considered suitable for use down to -200 °C.
- At temperatures below -70 °C the sensor foil of FHF will become rigid and brittle. It is important not to change the sensor position at low temperatures because it will likely break the sensor. At low temperatures the FHF sensor foil loses its flexibility but besides this, the sensors work just as normal.
- Users may order the standard FHF cable as a separate item. This is made of PFA; its temperature rating is -200 to + 260 °C.
- Users may solder signal wires to the foil by themselves following the directions in the manual of the sensor. If needed, seal the soldered connections using suitable potting material.
- If you expect small signals and want to know if a sensor still functions or if you want to monitor the stability, you can use the FHF05SC sensors. The heater materials are the same as the foil sensor. Soldering is also similar. The -SC version is available only for certain FHF05 sensor sizes.
- The sensitivity of the FHF sensors at low temperatures may become very low. Temperature dependence is around $< 0.2 \%/^{\circ}\text{C}$. So, at -200 °C, you have 64 % of the sensitivity left compared to the calibration reference situation at room temperature. Users may correct for temperature dependence of the sensitivity with the approximation of the manual of the sensor. This uses a temperature dependence of the sensitivity of $+ 0.2 \%/^{\circ}\text{C}$. If needed, for higher accuracy, Hukx can determine the sensitivity from +50 to -30 °C, which users can then extrapolate to the temperature of their application. This is an additional service available at extra cost.
- Use of optional BLK black stickers is limited to -40 °C. However, please note that in the infrared, the normal Kapton sensor surface behaves as a black emitter and absorber, so you may not need a black sticker.
- Use of the optional GLD gold stickers is limited to -185 °C.

7.9 Appendix on use of FHF sensor foils under vacuum conditions

FHF users have successfully employed the FHF05, FHF05SC and FHF06 sensor foils under vacuum conditions. Hukx does not specify the use under vacuum conditions because the application of any sensors, not just these, under vacuum is always high-risk. Use under vacuum conditions is possible but at the user's own risk.

NOTICE

Use of FHF05, FHF05SC and FHF06 sensor foils under vacuum conditions is possible, but at the user's own risk.

Directions for use under vacuum:

- Use the sensor foil only, not the cable connection block.
- The cable connection block between foil and cable is potted with an epoxy. The epoxy may outgas under vacuum. The sensor foils do not outgas.
- The FHF sensor foils are made using Kapton etched foil technology. The materials used are Kapton (polyimide), acrylic glue (not for FHF06) plus the metals of the sensor. This technology is generally considered suitable for use under vacuum. The outgassing is specified for the FHF06 foil.
- Under vacuum the sensors work just as normal.
- Users may order the standard FHF cable as a separate item. This is made of PFA which is formally rated for use under vacuum.
- Users may solder signal wires to the foil by themselves following the directions in the sensor manual. If needed, seal the soldered connections using suitable potting material.
- Model FHF06 sensor foil has a formal outgassing specification (low outgassing, 0.36 % total mass loss, 0.01 % collected volatile condensable material (CVCM) as per NASA-JSC).

7.10 Appendix on long-term use in condensing, wet, and underwater conditions

FHF users have employed the FHF05, FHF05SC and FHF06 sensors in condensing, wet and underwater conditions, also for periods of many years and at high water pressure. However, Hukx formally specifies such use under IP67 for short—30 minutes—duration and at a limited pressure—0.5 m of water—only. Long-term application under wet conditions is possible, but always high-risk and at the user's own risk.

Examples of successful application are:

- buried in the soil, exposed to rainwater
- in a high-pressure water vessel as part of a simulated service test for deep-sea pipelines (sensor foil only, not the cable connection block and not the sensor cable). In most cases, users make their own connection to the sensor foil
- mounted on the wall of a house, frequently exposed to rainwater

NOTICE

Use of FHF05, FHF05SC and FHF06 sensors under wet conditions beyond IP67 (0.5 m depth and 30 minutes exposure) is possible, but at the user's own risk.

Directions for use under wet conditions are:

- The sensor foil materials and the materials of the potted cable connection block can absorb a limited amount of water only. However, as a result of exposure to this absorbed water over a long term the alloys in the sensor foil and conductors in the cable may slowly corrode. Corrosion may result in loss of sensitivity. Corrosion may be noticed by measuring changes in electrical resistance, because corrosion leads to an increase of the electrical resistance.
- The sensor cable is not waterproof. It is open at the cable end. Operating in wet conditions, in case of damage to the cable and/or wire cladding the conductors may be directly exposed to water. In most cases, exposure to water has no effect; electrical resistance of water tends to be high. However, in case water conducts, for example, if it contains salts, this may lead to ground loops or loss of signal.
- Users should perform regular inspections of the sensor and the cable condition.
- Users may solder signal wires to the sensor foil by themselves following the directions in the sensor manual. In case of exposure to water, seal the soldered connections using suitable potting material.

7.11 Appendix on use of FHF sensor foils under pressure

Hukx specifies the use of FHF05 sensor foils to 8 bar uniform pressure. For model FHF06 this specification is 25 bar uniform pressure. This pressure may result from air or fluids under pressure or be mechanical pressure in case the sensor is clamped.

NOTICE

Use of FHF05, FHF05SC sensor foils above 8 bar pressure and FHF06 sensor foils above 25 bar pressure is possible, but at the user's own risk.

During the manufacturing process of our FHF06 sensors, an 8 bar pressure is used for the lamination process on the foil. So, the rated operating condition of 8 bar specification is safe. Previously, very similar heat flux sensors were manufactured at 40 bars. Thus, Hukx has reasonable confidence in the performance of the foils up to 40 bar, but any use above 8 bar is at the user's own risk.

The FHF06 sensor is manufactured under much higher pressure levels and does not contain acrylic glue layers. It is much stiffer and can be used up to 25 bar.

Directions for use under pressure:

- The pressure specification applies to the sensor foil only, not the cable and not the cable connection block.
- The pressure specification applies to uniform pressure only; avoid exercising mechanical pressure at one point on the foil.
- Users may solder a signal wire to the sensor foil by themselves following the directions in the sensor manual. In case of exposure to water, seal the soldered connections using suitable potting material.

7.12 EU declaration of conformity

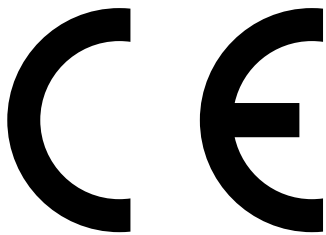

We, **Hukseflux Thermal Sensors B.V.**,
Delftechpark 31, 2628 XI, Delft,
The Netherlands

hereby declare under our sole responsibility that:

Product models	FHF06
Product type	Heat flux sensors
Brand name	Hukx

conform with the following directive(s):

2011/65/EU, EU 2015/863 The Restrict
ion of Hazardous Substances Directive

This conformity is declared using the relevant sections and requirements of the
following standards,

Hazardous substances	EU RoHS2 (2011/65/EU) and EU 2015/863 amendment known as RoHS 3
----------------------	--

Eric HOEKSEMA
Director
Delft, 22 May 2024

About Hukx

Hukx is the leading innovator in solar radiation and heat flux sensor technology. We are proud to set the standard in high-accuracy measurement, and to be working at the heart of the energy transition.

Customers worldwide rely on our bestselling pyranometers and heat flux sensors. From sensor design and selection to supply and recalibration, we support you across the entire lifecycle.

Hukx is headquartered in the Netherlands, with locally owned representative sales offices in the USA, Brazil, India, China, Southeast Asia, and Japan.

Let us help you select the best sensor for your application. Get in touch with our experts today via: info@hukx.com

© Hukx

v2506

We reserve the right to change specifications without prior notice.

www.hukx.com

HUKX