

HUKX

Sensor
Technology

User manual
Digital Class A
pyrheliometer

DR30-D1

Warning statements



Putting more than 30 Volt across the sensor wiring of the main power supply can lead to permanent damage to the sensor.



For proper instrument grounding:
Use DR30 with its original factory-made cable.



Using the same Modbus address for more than one device will lead to irregular behavior of the entire network.



Disconnect power while performing service or maintenance.

Contents

Introduction	6
1 Ordering and checking at delivery	12
1.1 Ordering DR30	12
1.2 Included items	13
1.3 Quick instrument check	13
2 Instrument principle and theory	14
2.1 Operating modes: heating	16
2.2 Overview of remote diagnostics	16
3 Specifications of DR30	17
3.1 Specifications	17
3.2 Dimensions of DR30	23
4 Standards and recommended practices for use	24
4.1 Classification standards	24
4.2 General rules for solar radiation measurement	25
4.3 General use for sunshine duration measurement	25
4.4 Specific use in meteorology and climatology	25
5 Use of remote diagnostics	26
5.1 Recommendations	26
5.2 Sensor temperature	26
5.3 Tilt angle	26
5.4 Internal relative humidity	27
5.5 Heater current	27
6 Installation of pyrheliometers	28
6.1 Site selection and installation	28
6.2 Installation of optional extension cable of 20 m	28
6.3 Mounting	29
6.4 Electrical connection	30
6.5 Grounding and use of the shield	31
6.6 Connecting to an RS-485 network	31
6.7 Connecting to a PC	32
7 Communication with DR30	33
7.1 PC communication: Sensor Manager software	33
7.2 Installing the Sensor Manager	33
7.3 Trouble shooting during Sensor Manager installation	33
7.4 Sensor Manager: plotting data	35
7.5 Sensor Manager: information about the instrument	36
7.6 Sensor Manager: changing Modbus address and communication settings	37
7.7 Sensor Manager: adjustment of the sensitivity by power users	38
7.8 Network communication: function codes, registers, coils	38
7.9 Network communication: getting started	49
7.10 Network communication: example master request to DR30	50
8 Making a dependable measurement	53
8.1 The concept of dependability	53
8.2 Reliability of the measurement	54
8.3 Speed of repair and maintenance	55

8.4	Uncertainty evaluation	55
8.5	Definition of the measurand	55
8.6	Contributions from circumsolar radiation	55
8.7	Instrument classification, and approaches to uncertainty evaluation	57
8.8	Evaluation of measurement uncertainty under outdoor conditions	57
8.9	Calibration uncertainty	59
9	Maintenance and trouble shooting	60
9.1	Recommended maintenance and quality assurance	60
9.2	Trouble shooting	61
9.3	Calibration and checks in the field	63
9.4	Data quality assurance	63
10	Appendices	64
10.1	Appendix on cable extension/replacement	64
10.2	Appendix on tools for DR30	65
10.3	Appendix on spare parts for DR30	65
10.4	Appendix on standards for classification and calibration	66
10.5	Appendix on calibration hierarchy	67
10.6	Appendix on requirements for solar tracking	68
10.7	Appendix on meteorological radiation quantities	69
10.8	Appendix on ISO and WMO classification tables	70
10.9	Appendix on the definition of pyrheliometer specifications	72
10.10	Appendix on terminology/glossary	74
10.11	Appendix on literature references	77
10.12	Appendix on floating point format conversion	78
10.13	Appendix on function codes, register and coil overview	79
10.14	EU declaration of conformity	84

List of symbols

quantities	symbol	unit
voltage output	U	V
solar irradiance	E	W/m ²
sensitivity	S	V/(W/m ²)
subscripts		
not applicable		

Introduction

DR30-D1 is Hukx's most advanced digital sensor for direct (normal incidence) solar radiation. This high-accuracy pyrheliometer complies with Class A specifications set by ISO 9060 and the WMO Guide. It features superior window heating that leads to high data availability and an internal tilt sensor to verify tracker performance.

Welcome to the next level in solar radiation monitoring! The all-digital DR30-D1 pyrheliometer offers the highest accuracy and data availability, featuring window heating at low offsets. At the same heating power, the heating has been improved by a factor of 4, at just a quarter of the offset! With on-board tilt and humidity sensors, the DR30-D1 is purpose-built for high-accuracy measurement of direct solar radiation—also known as Direct Normal Irradiance (DNI)—received by a plane surface from a 5 ° full field of view angle. DNI is expressed in W/m^2 . For optimal results, the instrument must be mounted on a two-axis tracker to stay pointed at the sun.

Heated for high data availability

High data availability is attained by heating the front window, which suppresses dew and frost deposition.

– low power consumption: DR30-D1 only needs 2 W to keep its window free from dew and frost.



Figure 0.1 DR30-D1 next-level digital first class pyrheliometer.

Remote sensor diagnostics

In addition to solar irradiance, DR30-D1 outputs sensor diagnostics such as:

- tilt angle
- internal humidity
- heater current

Remote diagnostics permit real-time status monitoring, reducing the need for (un)scheduled field inspections.

Liabilities covered: test certificates

Each DR30-D1 digital pyrheliometer is supplied with test results for the individual instrument:

- sensitivity
- response time
- temperature response
- tilt angle measurement

Instrument use

The DR30-D1 pyrheliometer is designed for tracker-mounted operation. It connects directly to commonly used data logging systems and offers a digital output via Modbus RTU over 2-wire RS-485.

DR30-D1 design

For communication between a PC and DR30, the Hukseflux Sensor Manager software can be used. It allows the user to plot and export data, and change the DR30 Modbus address and communication settings. Also, the digital outputs may be viewed for sensor diagnostics.

Hukseflux Sensor Manager software

For communication between a PC and DR30-D1, Hukseflux Sensor Manager software can be used.

It allows you to plot and export data, change the DR30-D1's Modbus address and communication settings, and view digital outputs for sensor diagnostics.

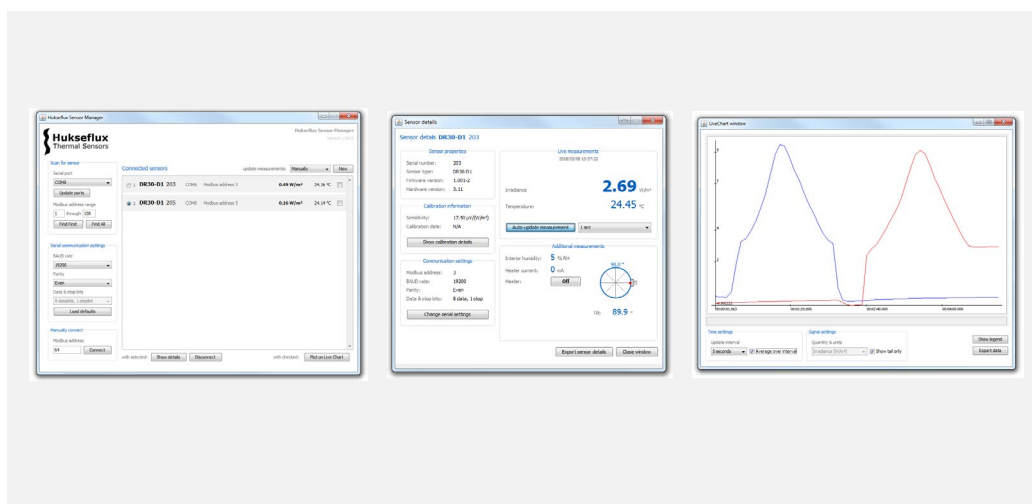

Figure 0.2 User interface of the Hukseflux Sensor Manager, showing sensor diagnostics.

Suggested use

- solar energy surveys
- solar resource assessments
- meteorological networks
- sites with dew and frost problems

Options

- longer cable; 10 and 20 m
- 20 m extension cable with 2 connectors



Figure 0.3 On the left, the DR30-D1 cable with M12-A female connector on sensor end, pigtails of 0.15 m and conductors with ferrules. Its length is 5 meters standard and available in 10 and 20 meters too. On the right, the optional Hukx extension cable with connector pairs, with male and female M12-A connectors, available in 20 meters.

A pyrheliometer can also be used to measure sunshine duration. Sunshine duration during a given period is defined as the sum of that sub-period for which the direct solar irradiance exceeds 120 W/m^2 .

DR30-D1 is designed for use in SCADA (Supervisory Control And Data Acquisition) systems, supporting Modbus RTU (Remote Terminal Unit) protocol over RS-485. In these networks, the sensor operates as a slave. SCADA systems are often implemented in photovoltaic solar energy (PV) systems and meteorological networks. Using DR30 in a network is easy. Once it has the correct Modbus address and communication settings and is connected to a power supply, the instrument can be used in RS-485 networks. The user should have sound knowledge of the Modbus communication protocol when installing sensors in a network.

The instrument should be used in accordance with the recommended practices of ISO, WMO and ASTM.

Applicable instrument classification standards are ISO 9060 and WMO-No. 8. Calibration is traceable to WRR (World Radiometric Reference).

Various tracking solutions can be offered by Hukx. Please contact us for more information on solar trackers.



Figure 0.4 Applications of DR30 and other pyrheliometers, mostly combined with pyranometers, in typical solar radiation monitoring stations.

Uncertainty evaluation

The uncertainty of a measurement under outdoor conditions depends on many factors. Guidelines for uncertainty evaluation (according to the "Guide to Expression of Uncertainty in Measurement" or GUM) can be found in our manuals.

We provide spreadsheets to assist you in evaluating the uncertainty of your measurements.

DR30-D1 user benefits

Using the DR30-D1 digital pyrheliometer offers significant benefits over competing models. The all-digital DR30-D1 pyrheliometer offers the highest accuracy and highest data availability, featuring heating at low offsets and on-board tilt and humidity sensors. The advantages of having a heater and tilt sensor are demonstrated in the following graphs:

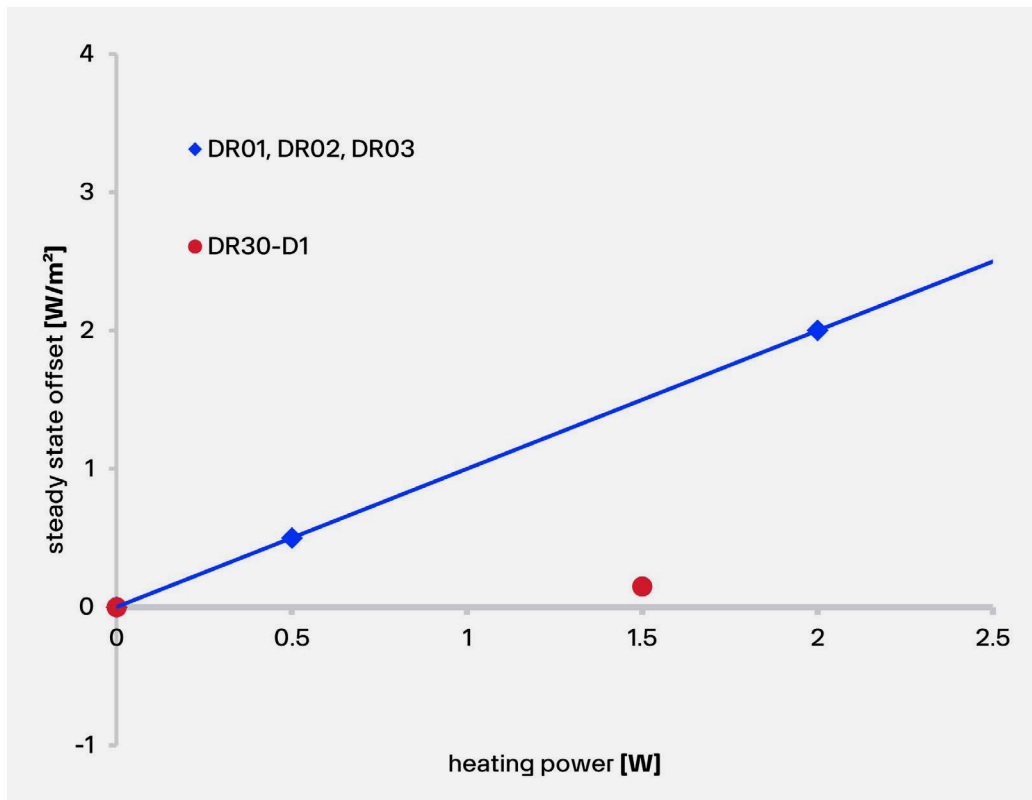

Figure 0.5 The offset of DR30 when heating is much improved relative to the older DR01, DR02 and DR03 models. DR30 has a 1.5 W heater and produces a negligible offset. The older models had offsets of the order of 2 W/m² at the same heating levels. In addition, the temperature of the front window of DR30 is 4 times higher than that of the older models, at the same heating power.

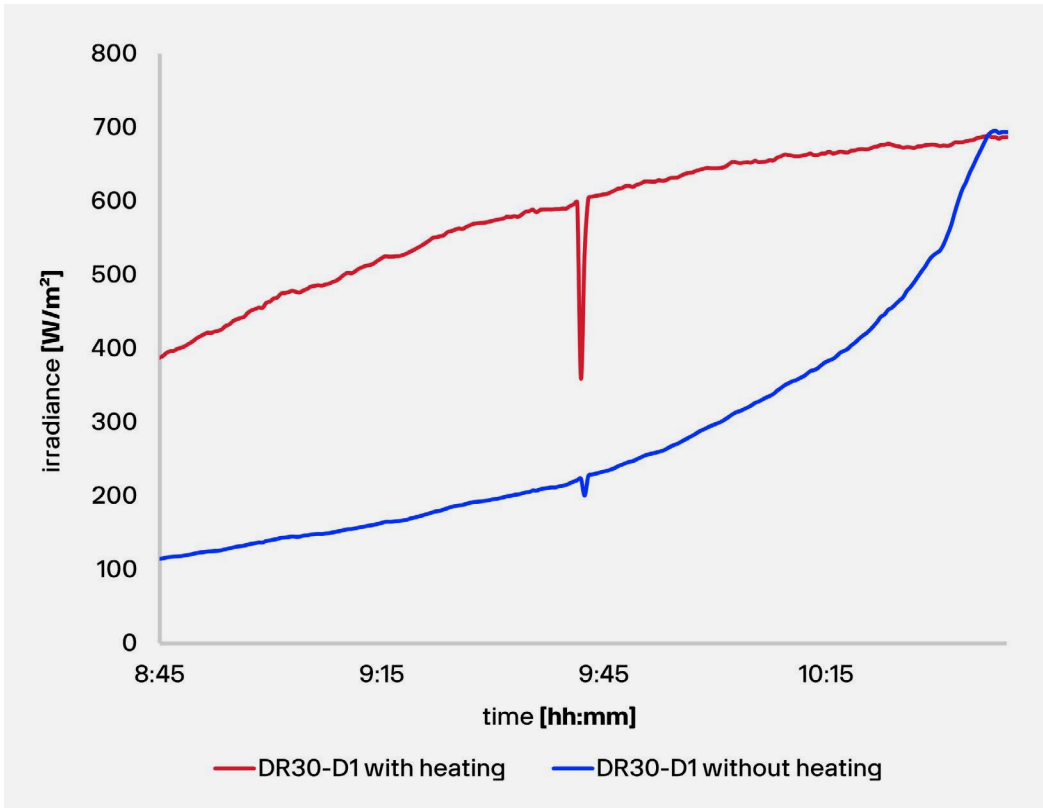

Figure 0.6 Comparison of the measured data with and without heating on a typical winter morning. The unheated DR30 has dew on its front window and strongly underestimates the incoming irradiance. At around 10:30 the dew evaporates. Real measured data from Delft, the Netherlands.

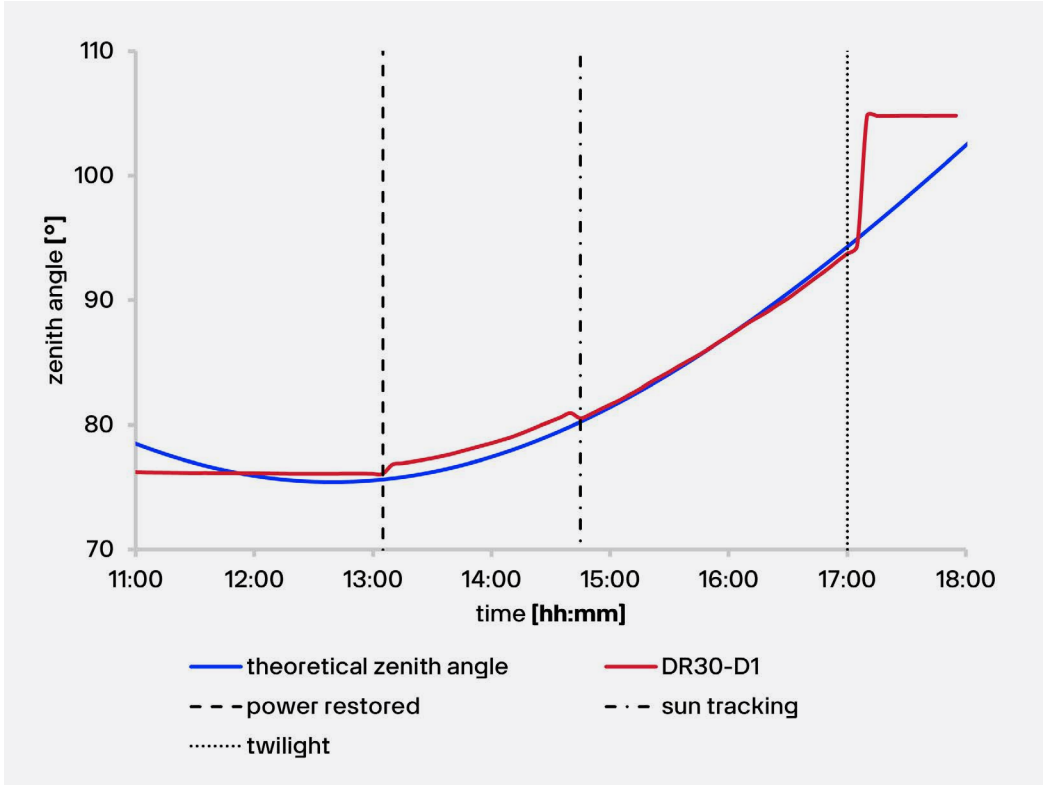

Figure 0.7 Example of use of the DR30 tilt sensor for tracker performance monitoring: the red line is the output of the DR30 tilt sensor, the blue line the theoretical zenith angle. There is a power failure before 13:00, at that time power is restored. Tracking between 13:00 and 15:00 is under cloudy conditions, based on GPS information only and slightly off. Tracking from 15:00 onwards is under sunny conditions and based on the tracker's sun sensor. The tracker moves to its rest position shortly after 17:00. Real measured data from Delft, the Netherlands.



Figure 0.8 DR30 next-level pyrhelimeter side view.

See also

- DR20-A1 and DR15-A1 analog, spectrally flat Class A & B pyrhelimeters, with heating
- View our complete [product range of sensors](#).

1 Ordering and checking at delivery

1.1 Ordering DR30

The standard configuration of DR30 is with 5 meters cable.

Common options are:

- longer cable; 10 and 20 meters
- 20 meters extension cable with 2 connectors. Specify article number C07E-20

Table 1.1.1 Ordering codes for DR30

Versions of DR30 (part numbers)	
DR30-D1	next-level digital first class pyrhelimeter, with heating, tilt sensor and Modbus over RS-485
cable for dr30, with female m12-a connector at sensor end, pigtailes of 0.15 m and conductors with ferrules	
'-05' after DR30 part number	standard cable length: 5 m
'-10' after DR30 part number	cable length: 10 m
'-20' after DR30 part number	cable length: 20 m
cable extension for r30, with male and female m12-a connectors	
C07E-20	cable length: 20 m

An extension cable (with connector pair) can be used in combination with a regular cable (with one connector at sensor end) to make alternative DR30 cable lengths possible.

1.2 Included items

Arriving at the customer, the delivery should include:

- pyrheliometer DR30
- cable of the length as ordered
- product certificate matching the instrument serial number, including
 - calibration certificate
 - temperature response test report
 - tilt sensor test report
- any other options as ordered

Please store the certificates in a safe place. The latest version of the Hukseflux Sensor Manager can be downloaded via www.hukx.com/downloads

1.3 Quick instrument check

A quick test of the instrument can be done by connecting it to a PC and installing the Sensor Manager software. See the chapters on installation and PC communication for directions. Please note that you will need a separate power supply; the sensor cannot be powered from the USB only.

1. At power-up the signal may have a temporary output level different from zero; an offset. Let this offset settle down; it is a normal part of the power-up procedure.
2. Check if the sensor reacts to light: expose the sensor to a strong light source, for instance a 100 W light bulb at the front window. The signal should read $> 100 \text{ W/m}^2$ now. Darken the sensor either by putting something over it or switching off the light. The instrument irradiance output should go down and within one minute approach 0 W/m^2 .
3. Place the instrument horizontal, the tilt angle output should be 90° .
4. Verify heater current, internal humidity.
5. Inspect the instrument for any damage. Check if the sight is straight and aligned.
6. Check the instrument serial number as indicated by the software against the label on the instrument and against the certificates provided with the instrument.



Figure 1.3.1 DR30 first class pyrheliometer front-view; window assembly with heater.

2 Instrument principle and theory

DR30's scientific name is pyrliometer. It measures the solar radiation received by a plane surface from a 5 ° full field of view angle. In addition to the full field of view angle, (the angle from the center of the sensor to the edge of the aperture window) WMO recommends in WMO manual 7.2 a slope angle (the angle from the side of the sensor to the edge of the window aperture) of 1 °. The opening angle and slope angle together with the sensor surface define the so-called acceptance function (see appendix on terminology).

A pyrliometer should measure 'direct' solar radiation, also called direct normal irradiance or DNI. DNI is defined as the solar radiant flux collected by a plane unit surface normal to the axis pointing towards the center of the sun, within an optical angular aperture. This aperture is characterized by the acceptance function (ref: Blanc et al. (2014), see appendix on terminology and appendix on literature references). DNI is composed of the solar irradiance within the extent of the solar disk (half-angle $0.266^\circ \pm 1.7\%$) plus some circumsolar radiation.

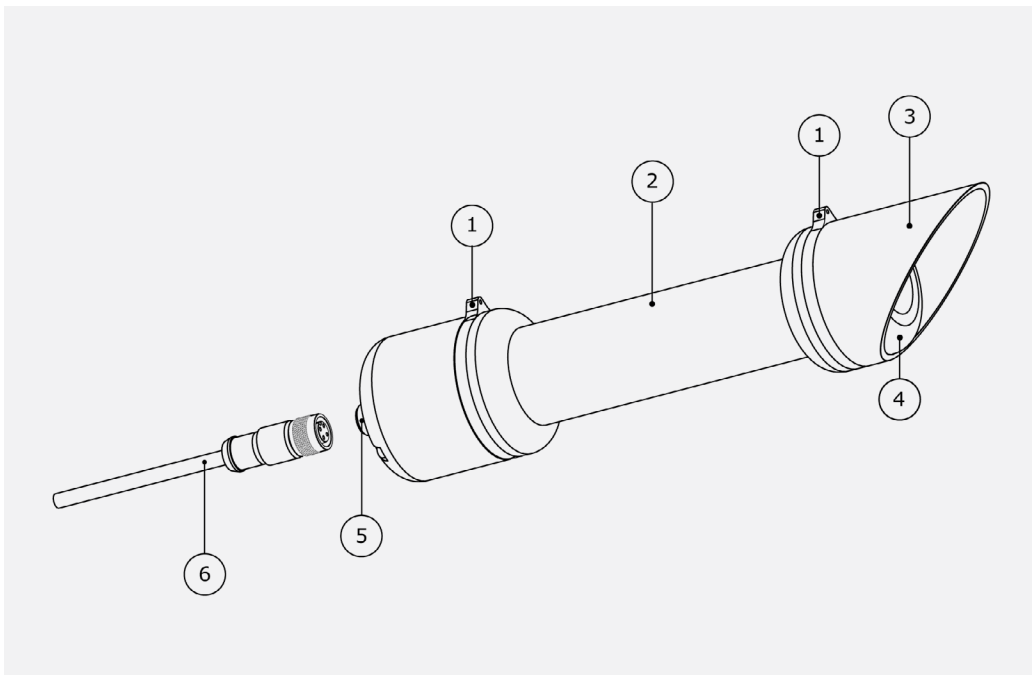

Figure 2.1 Overview of DR30:

1. sights
2. aperture tube
3. protection cap
4. window assembly with heater
5. connector
6. cable (standard length 5 meters, optional longer cable)

Summarizing, DR30 is a radiometer designed to measure DNI (i.e. including some circumsolar irradiance). It complies with the WMO recommended parameters for the view-limiting geometry: a full opening angle of 5 °, and a slope angle of 1 °, and therefore a limit angle of 4 °.

The solar radiation spectrum extends roughly from 285 to 3000×10^{-9} m. By definition, a pyrheliometer should cover that spectral range with a spectral selectivity that is as "flat" as possible.

For a correct measurement, DR30 should be pointed at the sun. It is usually mounted on a solar tracker. For tracking requirements, see the appendix on solar tracking.

In order to attain the proper directional and spectral characteristics, DR30 pyrheliometer's main components are:

- A thermal sensor with black coating. It has a flat spectrum covering the 200 to 50000×10^{-9} m range. The coating absorbs all solar radiation and, at the moment of absorption, converts it to heat. The heat flows through the sensor to the instrument body. The thermopile sensor generates a voltage output signal that is proportional to the solar irradiance.
- A quartz glass window. This window limits the spectral range from 200 to 4000×10^{-9} m (cutting off the part above 4000×10^{-9} m).
- An aperture tube. The most important components of this tube are two apertures. One at the detector and the other at the front window. These determine the opening and slope angle.
- A heater incorporated in the window assembly. This reduces measurement errors caused by (early-morning) dew deposition. By default, the heater is always on.
- A tilt sensor: this sensor measures tilt with a $\pm 1^\circ$ uncertainty. This is sufficient to monitor tracker performance.

Pyrheliometers can be manufactured to different specifications and with different levels of verification and characterization during production. The ISO 9060:1990 standard, "*Solar energy — specification and classification of instruments for measuring hemispherical solar and direct solar radiation*", distinguishes between 3 classes; secondary standard (highest accuracy), first class (second highest accuracy) and second class (third highest accuracy).

Due to the required spectral selectivity, a secondary standard pyrheliometer can only be made with a cavity-type sensor. In addition, the calibration of a secondary standard pyrheliometer must be done by periodic comparison with a primary standard radiometer. For this reason, commercially available thermopile pyrheliometers with a flat detector and a window can only be first class.

From first class to secondary standard, the achievable accuracy improves by a factor 2.

2.1 Operating modes: heating

A feature of DR30 is its built-in heater in the front window assembly. This is effective against dew and frost deposition.

There are 2 operating modes: standard and low power mode.

In standard operating mode, the heater is [ON], in low power mode the heater is [OFF]. Table 2.1.1 gives an overview of these settings and our recommendations for use.

Table 2.1.1 Possible user scenarios for the heater.

operating module	heater status	power in use (nominal)	comment
standard	[ON]	2 W	factory default recommended settings
low power	[OFF]	0.1 W	

Heating does not affect the classification specifications and the measurement accuracy.

Nominal heating power is 1.9 W. With around 0.1 W power to the electronics, the total power consumption is approximately 2 W.

2.2 Overview of remote diagnostics

Besides the digital output measuring irradiance in W/m^2 , DR30 has several sensors giving outputs which may be used for remote diagnostics. Remote monitoring of the sensor condition helps improve the accuracy and reliability of the measurement. It also allows to improve preventive maintenance and effective trouble shooting. Chapter 5 gives recommendations on how to use these diagnostics. Chapter 7 contains details on the register structure, needed for reading the remote diagnostics output.

A brief overview of the diagnostic signals and their respective registers:

- tilt angle with respect to zenith, "tilt angle average" register
- sensor body temperature, "sensor body temperature" register
- internal humidity, "humidity" register
- internal pressure, "pressure average" register
- heater current, "heater current" register

3 Specifications of DR30

3.1 Specifications

DR30 measures the solar radiation received by a plane surface from a from a 5 ° full field of view angle and a 1 ° slope angle, i.e. the acceptance function recommended by WMO. This quantity, expressed in W/m^2 , is called 'direct' solar radiation or direct normal irradiance (DNI). DNI can be used to calculate sunshine duration. DR30 offers irradiance in W/m^2 as a digital output. It must be used in combination with suitable power supply and a data acquisition system which uses the Modbus communication protocol over an RS-485 connection. It can only be used in combination with a solar tracker to keep it continuously aimed at the sun. The window assembly contains a heater to prevent dew deposition. The instrument is classified according to ISO 9060 and should be used in accordance with the recommended practices of ISO, IEC, WMO and ASTM.

Table 3.1.1 Specifications of DR30 (continued on next pages).

DR30 measurement specifications: list of classification criteria of iso 9060*	
ISO classification (ISO 9060:1990)	first class pyrheliometer
WMO performance level (WMO-No. 8, seventh edition 2008)	good quality pyrheliometer
response time (95 %)	4 s (nominal)
zero offset (response to 5 K/h change in ambient temperature)	$< \pm 1 W/m^2$
non-stability	$< \pm 0.5 \% \text{ change per year}$
non-linearity	$< \pm 0.2 \% (100 \text{ to } 1000 W/m^2)$
full field of view angle	5 °
slope angle	1 °
limit angle	4 ° (follows from full field of view angle and slope angle)
spectral selectivity	$< \pm 1 \% (0.35 \text{ to } 1.5 \times 10^{-6} m)$
temperature response	$< \pm 0.4 \% (-30 \text{ to } +50 \text{ °C})$

* For the exact definition of pyrheliometer ISO 9060 specifications see the appendix.

temperature response test of individual instrument	included
tilt response	$< \pm 0.2 \% (0 \text{ to } 90^\circ \text{ at } 1000 \text{ W/m}^2)$
Additional specifications	
measurand	direct solar radiation with the acceptance function recommended by WMO
measurand in SI radiometry units	irradiance in W/m^2
optional measurand	sunshine duration
measurement range	0 to 4000 W/m^2
measurement function/required programming for sunshine duration	if $E > 120 \text{ W/m}^2$ then $SD = 1$ else $SD = 0$
spectral range (50 % transmission points)	200 to $4000 \times 10^{-9} \text{ m}$
rated operating temperature range	$-40 \text{ to } +80^\circ \text{C}$
rated operating relative humidity range	0 to 100 %
output definition	running average over 4 measurements, refreshed every 0.1 s
recommended data request interval	1 s, storing 60 s averages
measurand	sensor temperature
sensor temperature measurement accuracy	$\pm 0.5^\circ \text{C}$
measurand	sensor tilt angle (relative to zenith)
tilt measurement uncertainty	$\pm 1^\circ (0 \text{ to } 180^\circ)$
tilt sensor characterization of individual instrument	report included
measurand	sensor internal relative humidity
humidity sensor uncertainty	$\pm 3\%$
measurand	sensor internal pressure
sensor uncertainty	$\pm 4 \text{ mbar}$
measurand	heater current

standards governing use of the instrument	<ul style="list-style-type: none"> – WMO-No. 8 <i>Guide to Meteorological Instruments and Methods of Observation</i>, Chapter 7, measurement of radiation, 7.2 measurement of direct solar radiation – ASTM G183-15 <i>Standard Practice for Field Use of Pyranometers, Pyrheliometers and UV Radiometers</i> – WCRP-121, WMO/TD-No. 1274: BSRN operations manual version 2.1-2005 – WMO-No. 8 <i>Guide to Meteorological Instruments and Methods of Observation</i>, Chapter 8, measurement of sunshine duration, 8.2.1 pyrheliometric method
total sensor length including cap	277 x 10 ⁻³ m
standard cable length (see options)	5 m
cable diameter	4.8 x 10 ⁻³ m
chassis connector	M12-A straight male connector, male thread, 5-pole
chassis connector type	M12-A
cable connector	M12-A straight female connector, female thread, 5-pole
cable connector type	M12-A
connector protection class	IP67 (connected)
cable replacement	Replacement cables with connector can be ordered separately from Hukx.
mounting	Mounting with 1 or 2 clamps around the pyrheliometer tube Ø 38 x 10 ⁻³ m, clamp to clamp distance of 120 x 10 ⁻³ m max. Contact the factory for solar tracker compatibility.
IP protection class	IP67
desiccant	3 bags of silica gel, 1 g, (45 x 24 x 4) x 10 ⁻³ m
desiccant replacement	> 5 year interval, typically replaced during recalibration, ask the manufacturer for instructions.

Standard operating mode

standard operating mode	heater [ON]
-------------------------	-------------

supply voltage range	7 to 30 VDC
----------------------	-------------

power consumption	2 W
-------------------	-----

Low power operating mode

operating condition	heater [OFF]
---------------------	--------------

supply voltage range	5 to 30 VDC
----------------------	-------------

power consumption	0.1 W
-------------------	-------

Shipping

gross weight including 5 m cable	approx. 1 kg
----------------------------------	--------------

net weight including 5 m cable	approx. 0.5 kg
--------------------------------	----------------

Tracking and alignment

required tracking	The instrument must be pointed at the sun center.
-------------------	---

required alignment	The pyrheliometer and the tracker should be aligned using the pyrheliometer sight.
--------------------	--

rated misalignment interval (without impact on measurement accuracy)	$\pm 0.5^\circ$ from the sun center, using the pyrheliometer sight as a reference
---	---

sight resolution	$< 0.2^\circ$ light-spot projection $< 25\%$ off target hole
------------------	---

sight sensitivity	$2.5 \times 10^{-3} \text{ m}/^\circ$
-------------------	---------------------------------------

Window assembly with heater

heater operation	By default the heater is always on. The heater can be switched on and off by writing to coil 1. See the chapter on communication. Changing the default heater state can be done using the Hukseflux Sensor Manager.
------------------	---

heater voltage	5 V (independent of supply voltage)
----------------	-------------------------------------

heater power	1.5 W
--------------	-------

steady state zero offset caused by heating	< 0.1 W/m ²
Calibration	
calibration traceability	to WRR
calibration hierarchy	From WRR through ISO 9059, applying a correction to reference conditions.
calibration method	Indoor comparison to a reference pyrhelimeter.
calibration uncertainty	< 1.2 % (k = 2)
recommended recalibration interval	2 years
reference conditions	20 °C, horizontal mounting, irradiance level 1000 W/m ²
validity of calibration	Based on experience the instrument sensitivity will not change during storage. During use under exposure to solar radiation the instrument "non-stability" specification is applicable.
adjustment after re-calibration	Via a PC, as <i>power user</i> with the Sensor Manager software. Request "power user" status at the factory for sensitivity adjustment and for writing the calibration history data.
Measurement accuracy and resolution	
uncertainty of the measurement	Statements about the overall measurement uncertainty can only be made on an individual basis. See the chapter on uncertainty evaluation.
WMO estimate on achievable uncertainty for minute sums (see appendix for a definition of the measurement conditions)	1.8 %
WMO estimate on achievable uncertainty for hourly sums (see appendix for a definition of the measurement conditions)	1.5 %
WMO estimate on achievable uncertainty for daily sums (see appendix for a definition of the measurement conditions)	1.0 %
irradiance resolution	0.05 W/m ²
instrument body temperature resolution	7.8 x 10 ⁻³ °C
instrument body temperature accuracy	± 0.5 °C
instrument tilt measurement accuracy	± 1°

Digital communication

digital output	irradiance in W/m ² instrument body temperature in °C instrument tilt angle in ° instrument internal humidity in % instrument internal pressure in Pa heater current in A
rated operating voltage range	7 to 30 VDC
communication protocol	Modbus over 2-wire RS-485 half duplex
transmission mode	RTU
common mode range	± 25 V
system requirements for use with PC	Windows 7 and later, USB or RS-232 (COM) port and connector, RS-485 / USB converter or RS-485 / RS-232 converter, Java Runtime Environment – software version 8, Hukseflux Sensor Manager – software version v1815 or higher
software requirements for use with PC	Java Runtime Environment – software available free of charge at http://www.java.com
user interface on PC	Hukseflux Sensor Manager software. Please check https://www.hukx.com/downloads

Options

longer cable: 10 or 20 meter length cable with M12-A female connector on sensor end, stripped (pigtails of 0.15 m and conductors with ferrules) on other end	option code = total cable length
extension cable with connector pair, 20 m length cable with male and female M12-A connectors	option code = C07E-20 for 20 meters

3.2 Dimensions of DR30

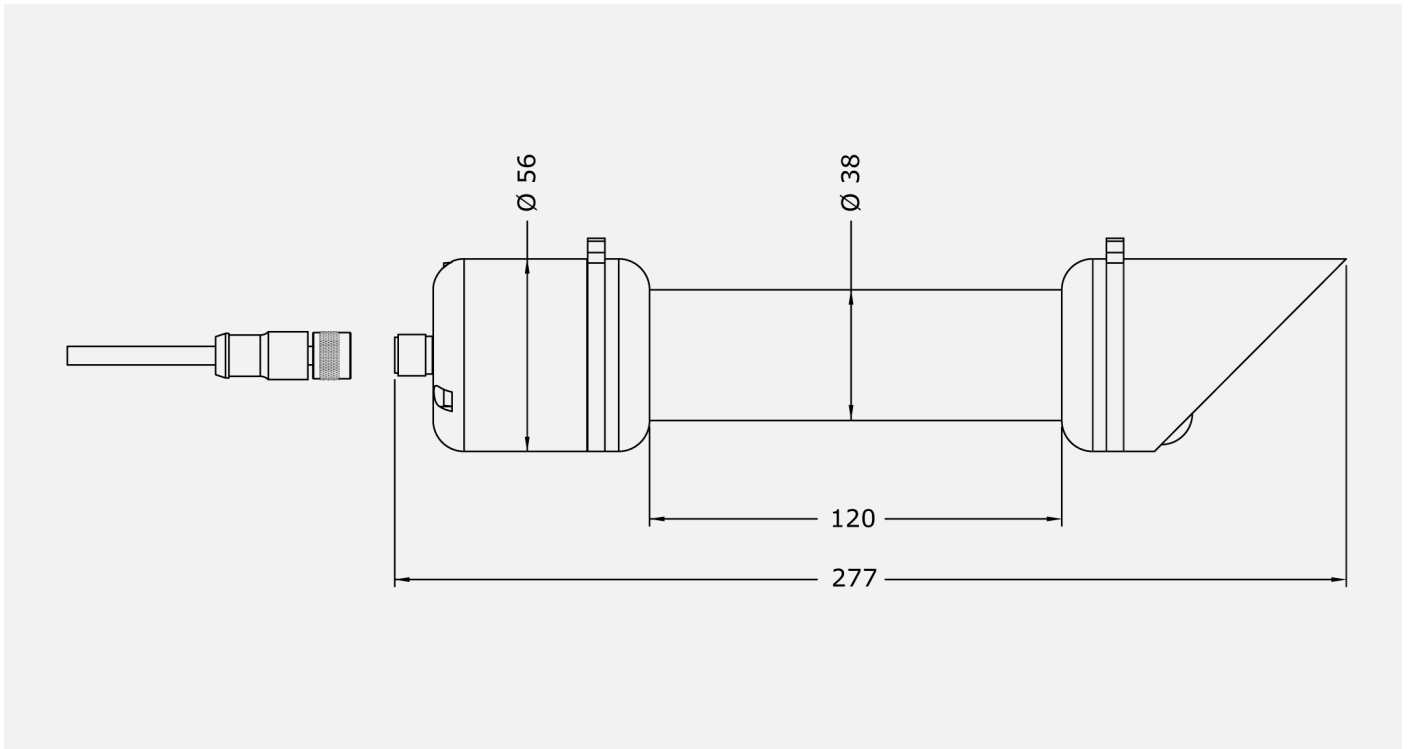

Figure 3.2.1 Dimensions of DR30
in $\times 10^{-3}$ m.

4 Standards and recommended practices for use

Pyrheliometers are classified according to the ISO 9060 standard and the WMO-No. 8 *Guide to Meteorological Instruments and Methods of Observation*. In any application the instrument should be used in accordance with the recommended practices of ISO, IEC, WMO and/or ASTM.

4.1 Classification standards

Table 4.1.1 Standards for pyrheliometer classification. See the appendix for definitions of pyrheliometer specifications, and a table listing the specification limits.

Standards for instrument classification		
ISO standard	equivalent ASTM standard	WMO
ISO 9060:1990 <i>Solar energy — Specification and classification of instruments for measuring hemispherical solar and direct solar radiation</i>	not available	WMO-No. 8 <i>Guide to Meteorological Instruments and Methods of Observation</i> , Chapter 7, measurement of radiation, 7.2 measurement of direct solar radiation

4.2 General rules for solar radiation measurement

Table 4.2.1 Standards with recommendations for instrument use in solar radiation measurement.

standards for instrument use for direct solar radiation		
ISO standard	equivalent ASTM standard	WMO
not applicable	ASTM G183-15 <i>Standard Practice for Field Use of Pyranometers, Pyrheliometers and UV Radiometers</i>	WMO-No. 8 <i>Guide to Meteorological Instruments and Methods of Observation</i> , Chapter 7, measurement of radiation, 7.2 measurement of direct solar radiation WCRP-121, WMO/TD-No. 1274: BSRN operations manual version 2.1-2005

4.3 General use for sunshine duration measurement

According to the World Meteorological Organization (WMO, 2003), sunshine duration during a given period is defined as the sum of that sub-period for which the direct solar irradiance exceeds 120 W/m^2 .

WMO has approved the “pyrheliometric method” to estimate sunshine duration from pyrheliometer measurements (Chapter 8 of the WMO Guide to Instruments and Observation, 2008). This implies that pyrheliometers may be used, in combination with appropriate software to determine the threshold of 120 W/m^2 , to measure sunshine duration.

Table 4.3.1 Standards with recommendations for instrument use in sunshine duration measurement.

standards for instrument use for direct solar radiation	
ISO standard	WMO
not applicable	WMO-No. 8 <i>Guide to Meteorological Instruments and Methods of Observation</i> , Chapter 8, measurement of sunshine duration, 8.2.1 Pyrheliometric Method

4.4 Specific use in meteorology and climatology

The World Meteorological Organization (WMO) is a specialized agency of the United Nations. It is the UN system's authoritative voice on the state and behavior of the earth's atmosphere and climate. WMO publishes WMO-No. 8; *Guide to Meteorological Instruments and Methods of Observation*, in which a table is included on “level of performance” of pyrheliometers. Nowadays WMO conforms itself to the ISO classification system.

5 Use of remote diagnostics

Remote monitoring of the sensor condition helps improve the accuracy and reliability of the measurement. It also allows to improve preventive maintenance and effective trouble shooting. The following remote diagnostics signals are part of the digital output. It is up to the user whether or not to use these diagnostics.

Chapter 7 contains details on the register structure, needed for reading the remote diagnostics output.

5.1 Recommendations

For remote diagnostics, we recommend to measure and store internal sensor humidity and heater current at 24:00 local time. We recommend to measure instrument tilt angle every 5 minutes and generate a warning if the difference between instrument tilt angle and theoretical zenith angle for your site is more than 2° . We recommend to use the Tilt angle average register. If your tracker goes through an early morning test cycle, you may wish to measure tilt angle at a higher frequency during that cycle. We recommend to check the sensor temperature against the dewpoint or ambient temperature. In general, the sensor temperature should be higher than ambient temperature and dewpoint. We recommend to monitor internal humidity trends on a yearly scale, using night-time values only, and generate a warning if the relative humidity is consistently $> 50\%$ at body temperatures $< 20^\circ\text{C}$. We recommend to monitor heater current and generate a warning if the current is below 0.25 A.

5.2 Sensor temperature

DR30's low temperature dependence makes it an ideal candidate for use under very cold and very hot conditions. Measurement of the sensors temperature is done using a high accuracy digital sensor temperature sensor. The sensor signal serves to externally monitor the DR30 temperature and, at the same time, is used by the internal electronics for temperature correction of the measurands. The temperature dependence of every individual instrument is tested and supplied on the product certificate as a second degree polynomial. Temperature correction of the irradiance signal is programmed into each sensor, and is taken care of fully automatically by the internal electronics. The temperature measurement can also be used to check that the sensor remains above dewpoint.

5.3 Tilt angle

To allow remote monitoring of the instrument tilt and to monitor tracker performance, the DR30 features a digital tilt sensor. The tilt sensor measures the instrument angle on three axes and calculates the corresponding tilt angle with respect to zenith internally. Zenith is defined as 0° .

For an accurate absolute measurement of the tilt angle with respect to zenith, each individual sensor is factory calibrated relative to the optical axis of the pyrheliometer and an independent tilt measurement. Also, the temperature correction coefficients of the tilt measurement are determined and programmed during production.

The tilt sensor characterization results are provided for each individual sensor on the product certificate.

The tilt sensor has an accuracy of $\pm 1^\circ$. This is sufficient to monitor tracker performance. The figure below shows an example of the use of the DR30 tilt sensor for tracker performance monitoring.

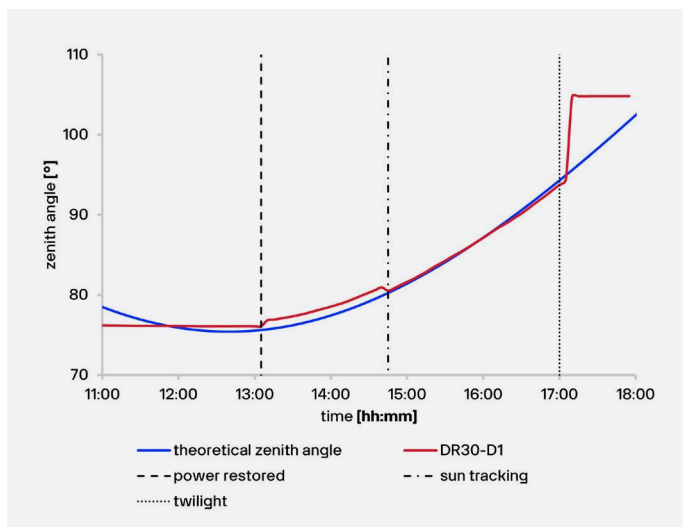

Figure 5.3.1 Example of use of the DR30 tilt sensor for tracker performance monitoring: the red line is the output of the DR30 tilt sensor, the blue line the theoretical zenith angle. There is a power failure before 13:00, at that time power is restored. Tracking between 13:00 and 15:00 is under cloudy conditions, based on GPS information only and slightly off. Tracking from 15:00 onwards is under sunny conditions and based on the tracker's sun sensor. The tracker moves to its rest position shortly after 17:00. Real measured data from Delft, the Netherlands.

5.4 Internal relative humidity

When the DR30 accumulates too much moisture, the internals of the sensor will get damaged. Therefore, it is advised to take regular measurements of the internal relative humidity of the sensor. These measurement are made available in the "humidity" register. We recommend to take regular measurements of the internal humidity of the sensor. The long-term (yearly) trend in relative humidity will show the slow saturation of the internal desiccant. The desiccant replacement interval is > 5 years. The relative humidity levels in the sensor depend both on the absolute temperature and the desiccant. The desiccant releases absorbed water as a function of temperature and saturation level. Because of these effects, the short-term relative humidity measurement is not a good indicator of the desiccant condition. The relative humidity levels are preferably measured at low temperatures; we recommend to store measurements taken around midnight (24:00 local time) and monitor changes on a yearly basis. The combined accuracy of the relative humidity sensor is approximately 5 % of the reading.

5.5 Heater current

The heater current measurement is an indicative, unverified measurement. Using the heater current reading, an estimation of the heater power can be made. Because the voltage across the heating element is 5.0 Volt, the heater power is given by:

$$P_{\text{heater}} [\text{W}] = 5.0 [\text{V}] \times \text{"heater current"} [\text{A}]$$

6 Installation of pyrheliometers

6.1 Site selection and installation

Table 6.1.1 Recommendations for installation of pyrheliometers.

location	The horizon should be as free from obstacles as possible. Ideally there should be no objects between the course of the sun and the instrument.
mechanical mounting/thermal insulation	Preferably, use the tube for clamping the instrument. A pyrheliometer is sensitive to thermal shocks. Do not mount the instrument on objects that become very hot (black coated metal plates).
performing a representative measurement	The pyrheliometer measures the solar radiation in a limited field of view. A representative measurement requires that the instrument is accurately pointing towards the sun center. A maximum deviation of better than 0.75° is allowed before it results in measurement errors. Use the sight of the pyrheliometer as a reference. See the chapter on uncertainty evaluation.

6.2 Installation of optional extension cable of 20 m

Extension to longer cable lengths is achieved by adding extension cables of 20 m with 2 connectors, male and female M12-A.



Figure 6.2.1 Optional extension cable of 20 meters with 2 connectors.

6.3 Mounting

DR30 is typically mounted on a solar tracker using mounting brackets. The pyrhelimeter has an aperture tube with dimensions fitting on common solar tracker models with 38×10^{-3} m tube clamps. See Chapter 3 for the dimensions of DR30. Contact the factory for tracker compatibility.

An essential part of mounting is to align the pyrhelimeter with its sights before fixating it to the tracker. When correctly aligned, the shadow of the instrument front sight should project neatly onto the rear sight throughout the day. For more details about alignment, see Appendix 10.6.

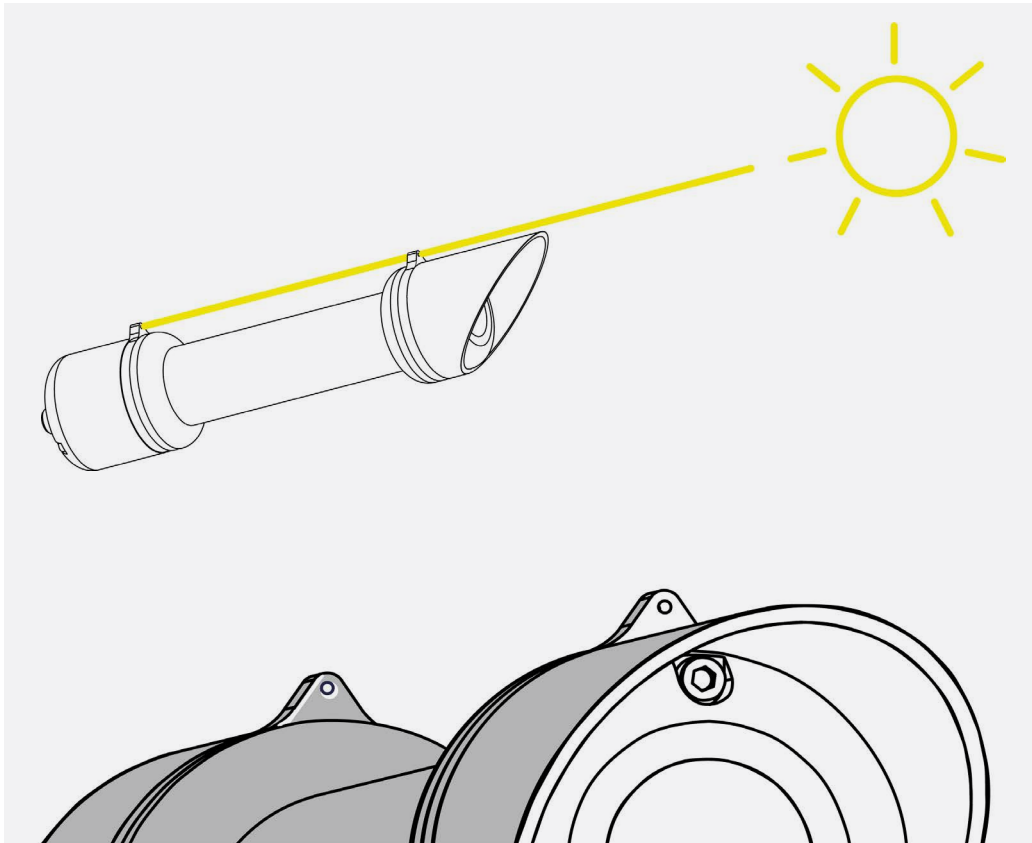

Figure 6.3.1 Aligning the DR series pyrhelimeter using its sights: the shadow of the front sight should project neatly onto the rear sight throughout the day.

The alignment sights might act as capillaries and gather water, which hinders alignment. If the sights do happen to have water in them, dry them using a bit of tissue or by blowing them dry.

Alignment requires that there are no blockages between the instrument's sights. The sight dimension is such that no blockage occurs on commonly used trackers.

6.4 Electrical connection

The instrument must be powered by an external power supply, providing an operating voltage in the range from 7 to 30 VDC. This is the main power supply for the sensor, using the brown and black wires. Do not put more than 30 Volt across these wires, this will damage the sensor.

Table 6.4.1 Wiring diagram of DR30-D1.

PIN	wire	DR30-D1 Modbus over RS-485
1	brown	VDC [+]
4	black	VDC [-]
3	blue	not connected
2	white	RS-485 B / B' [+]
5	gray	RS-485 A / A' [-]
-	yellow	shield

Note 2: at the connector-end of the cable, the shield is connected to the connector housing.

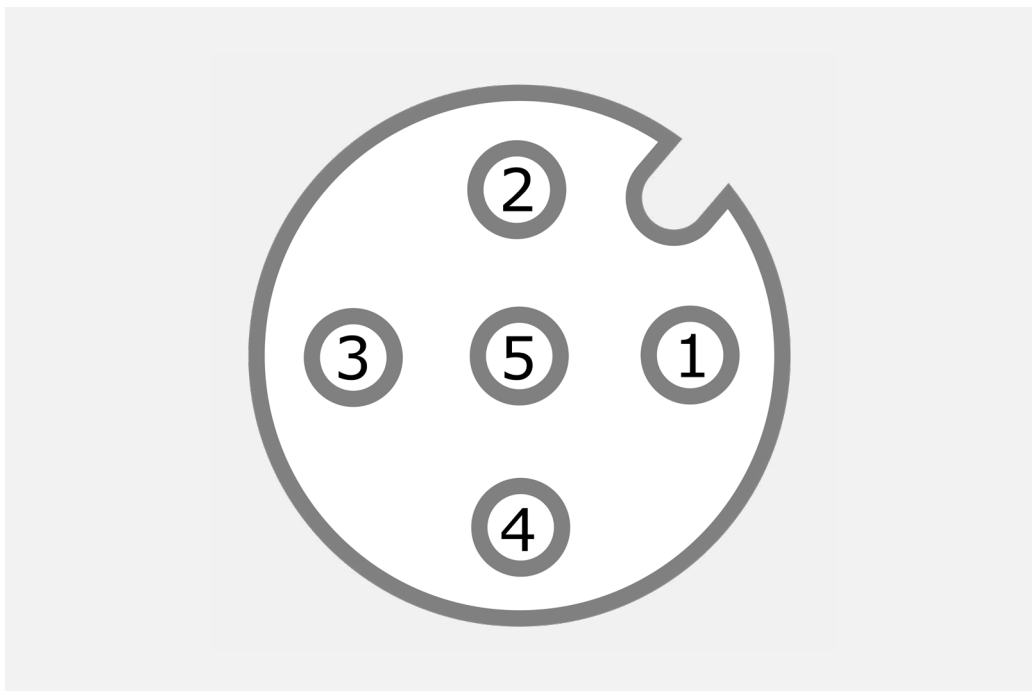

Figure 6.4.1 Connector layout of DR30, indicating PIN numbers (viewed from cable side).

6.5 Grounding and use of the shield

Grounding and shield use are the responsibility of the user. The cable shield (called shield in the wiring diagram) is connected to the aluminum instrument body via the connector. In most situations, the instrument will be screwed on a mounting platform that is locally grounded. In these cases, the shield at the cable end should not be connected at all. When a ground connection is not obtained through the instrument body, for instance in laboratory experiments, the shield should be connected to the local ground at the cable end. This is typically the ground or low voltage of the power supply or the common of the network. In exceptional cases, for instance when both the instrument and a data logger are connected to a small size mast, the local ground at the mounting platform is the same as the network ground. In such cases, ground connection may be made both to the instrument body and to the shield at the cable end.

6.6 Connecting to an RS-485 network

DR30-D1 is designed for a two-wire (half-duplex) RS-485 network. In such a network, DR30 acts as a slave, receiving data requests from the master.

An example of the topology of an RS-485 two-wire network is shown in the Figure below. DR30-D1 is powered from 7 to 30 VDC. The power supply is not shown in the figure. The VDC [-] power supply ground must be connected to the common line of the network.

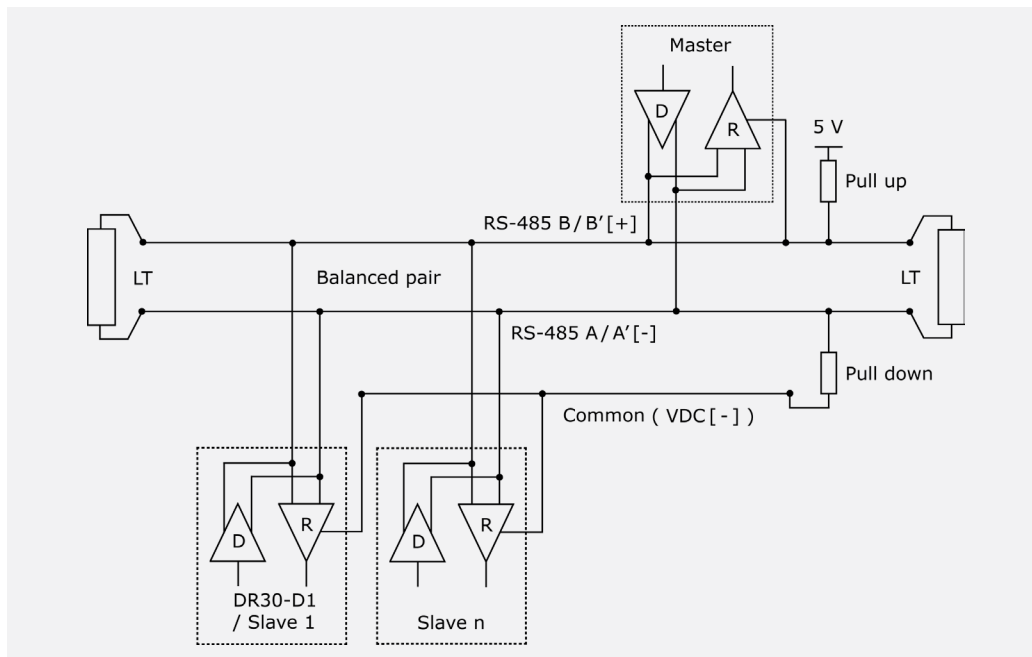

Figure 6.6.1 Typical topology of a two-wire RS-485 network, figure adapted from: Modbus over serial line specification and implementation guide V1.02 (www.modbus.org). The power supply is not shown in this figure.

After the last nodes in the network, on both sides, line termination resistors (LT) are required to eliminate reflections in the network. According to the EIA/TIA-485 standard, these LT have a typical value of 120 to 150 Ω . Never place more than two LT on the network and never place the LT on a derivation cable. To minimize noise on the network when no transmission is occurring, a pull up and pull down resistor are required. Typical values for both resistors are in the range from 650 to 850 Ω .

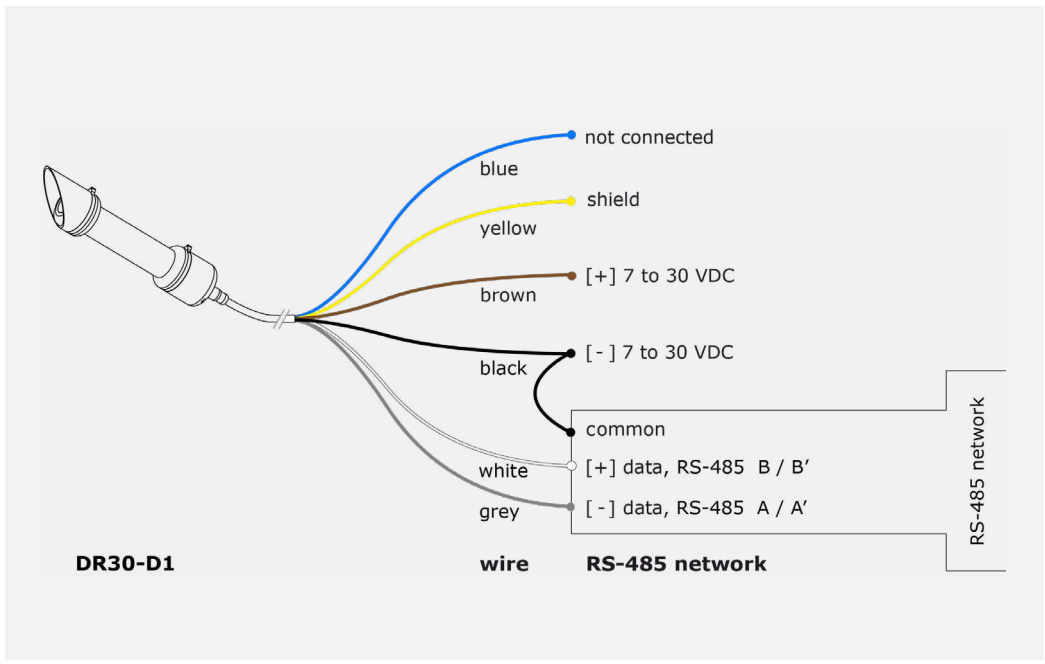

Figure 6.6.2 Connection of DR30 to an RS-485 network. DR30 is powered by an external power supply of 7 to 30 VDC.

6.7 Connecting to a PC

DR30 can be accessed via a PC. In that case communication with the sensor is done via the user interface offered by the Sensor Manager software (see the next chapters) or by another Modbus testing tool.

Depending on the available ports on the PC, either an RS-485 to USB converter or an RS-485 to RS-232 converter is used. The Figure below shows how connections are made. The converter must have galvanic isolation between signal input and output to prevent static electricity or other high-voltage surges to enter the data lines. An external power supply is required to power the DR30 (7 to 30 VDC). An RS-485 to USB converter is usually powered via the USB interface: in this case no external power is needed to feed the converter. If an RS-485 to RS-232 converter is used, this converter should be powered by an external source. This may be the same supply used for the DR30.

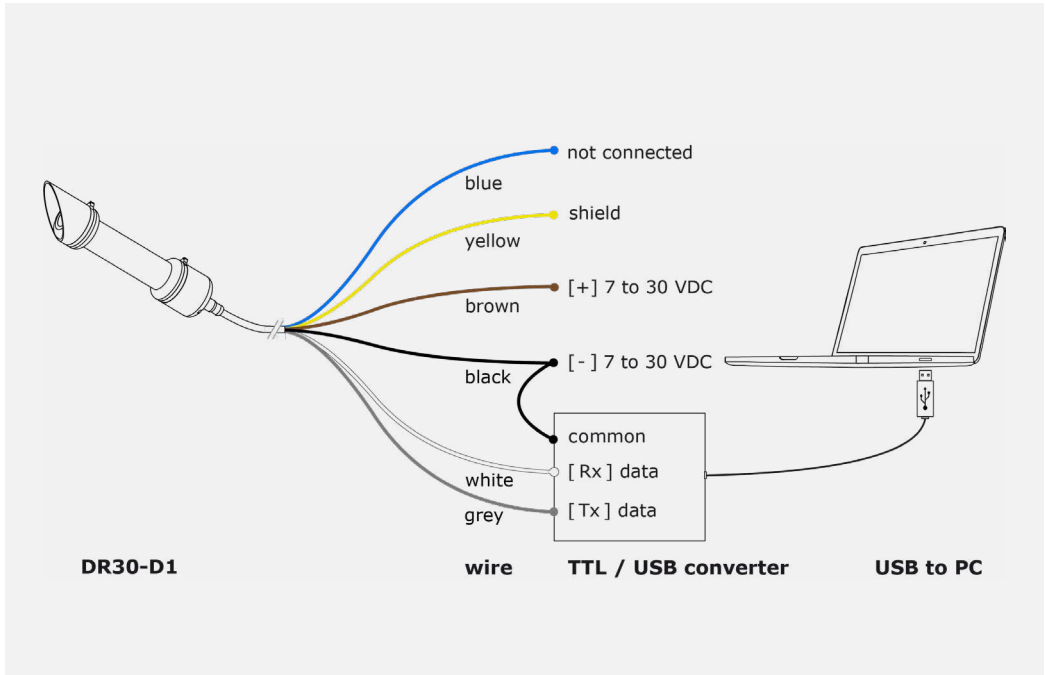

Figure 6.7.1 Connecting DR30 to an RS-485 to USB converter and a PC.

7 Communication with DR30

7.1 PC communication: Sensor Manager software

DR30-D1 can be accessed via a PC. In that case, the communication with the sensor is done via the user interface offered by the Sensor Manager software or by another Modbus testing tool. There are links to testing tools, paid or freeware, available at www.modbus.org

This chapter describes the functionality of the Sensor Manager only.

The Hukseflux Sensor Manager software provides a user interface for communication between a PC and DR30. It allows the user to locate, configure and test one or more DR30's and to perform simple laboratory measurements using a PC. The Sensor Manager's most common use is for initial functionality testing and modification of the DR30 Modbus address and communication settings. It is not intended for long-term continuous measurement purposes. For available software updates of the Sensor Manager, please check <https://www.hukx.com/downloads>

7.2 Installing the Sensor Manager

Running the Sensor Manager requires installation of version 8.0 of Java Runtime Environment software. Java Runtime Environment may be obtained free of charge from www.java.com. The DR30 specifications overview (Table 3.1.1) shows the system and software requirements for using a PC to communicate with DR30. Note that Java Runtime Environment 9.0 is currently not supported. For available software updates, please check <https://www.hukx.com/downloads>

To install the Hukseflux Sensor Manager from a download, follow these steps:

1. Download the Hukseflux Sensor Manager software from <https://www.hukx.com/downloads>
2. Right click the .zip file and select "Extract All...".
Extract the files to the desired destination folder.
3. Double-click "hsm-vxxxx.jar" in the folder "HSM-vxxxx"

7.3 Trouble shooting during Sensor Manager installation

When Java Runtime Environment software is not installed, a Windows message comes up, displaying "the file "Hukx_Sensor_Manager.jar" could not be opened". The solution is to install Java Runtime Environment version 8 on the PC and try again.

7.3.1 Sensor Manager: main window

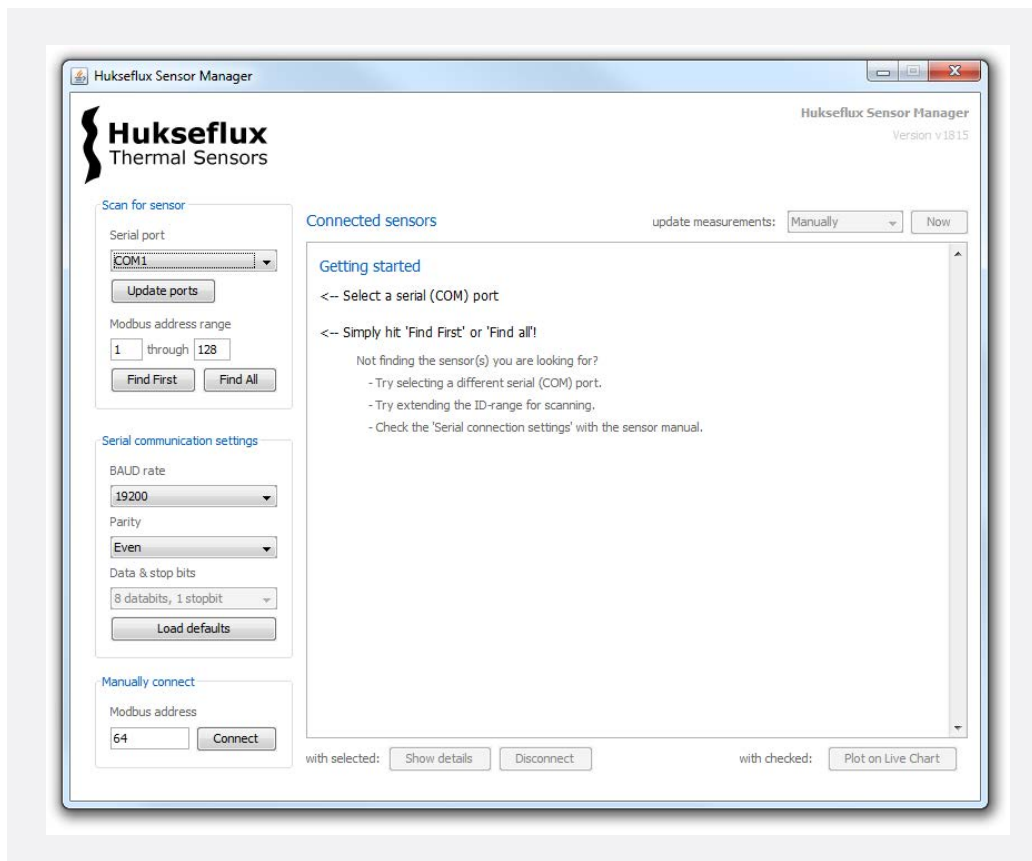

Figure 7.3.1: Main window of the Sensor Manager.

When the Sensor Manager is started and an DR30 is connected to the PC, the user can communicate with the instrument.

If the instrument address and communication settings are known, the serial connection settings and the Modbus address can be entered directly. Clicking "Connect" will establish contact.

If the instrument address and communication settings are not known, the instrument is found by using the "Find First" or "Find All" function. The Sensor Manager scans the specified range of Modbus addresses, however only using the "Serial connection settings" as indicated on screen. When only one sensor is connected, using "Find First" is suggested because the operation stops when a sensor is found. "Find All" will continue a scan of the complete range of Modbus addresses and may take extra time.

If the "Find First" or "Find all" operation does not find instruments, a dialog box opens, asking to confirm a scan of the address range using all possible communication settings. The time this operation takes, depends on the address range to be scanned. A complete a scan of 247 addresses will take over 15 minutes. When an instrument is found, a dialog box opens providing its serial number, Modbus address and communication settings. Communicating with the instrument is possible after changing the communication settings and Modbus address in the main window to the values of the instrument, and then clicking "Connect".

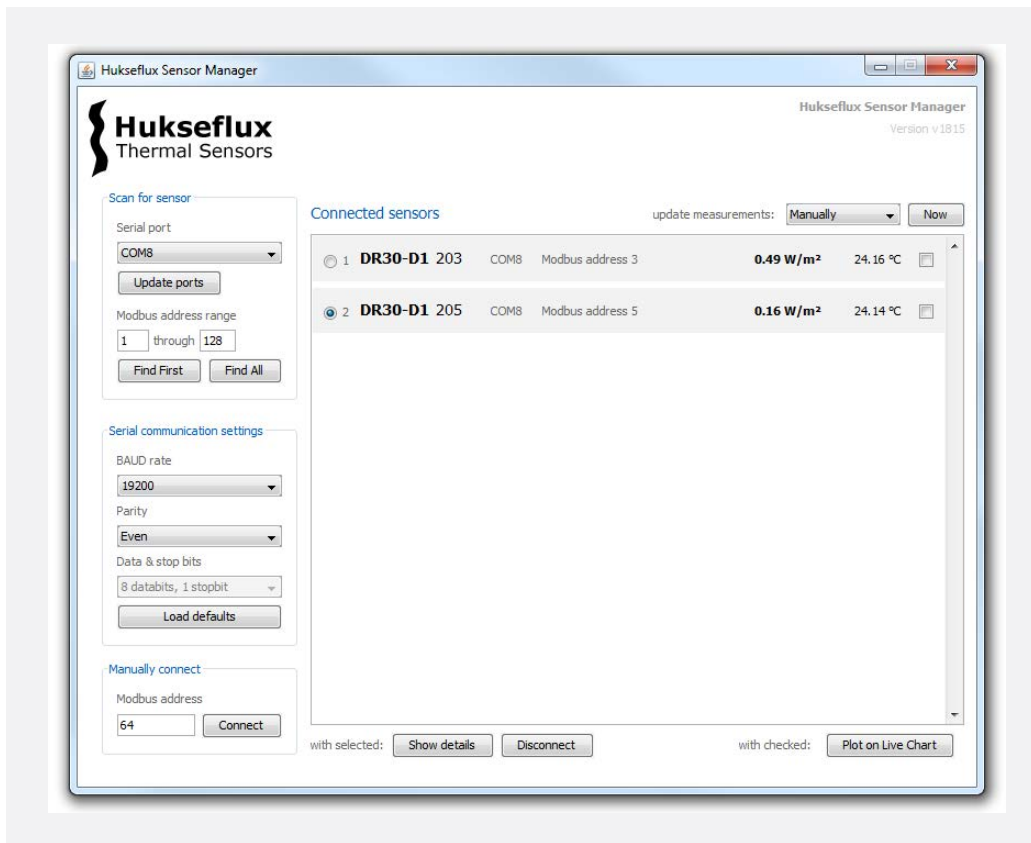

Figure 7.3.1.2 Sensor Manager main window with two connected DR30's.

When an instrument is found, temperature and irradiance data are displayed. Updates are done manually or automatically. Automatic updates can be made every second, every 5 seconds or every minute.

7.4 Sensor Manager: plotting data

When the "Plot on Live Chart" button in the lower right corner is clicked the "LiveChart window" opens. A live graph is shown of the measurement with the selected instruments. The x-axis, time, is scaled automatically to display data of the complete measurement period. After checking the box "Show tail only", only the last minutes of measured data are displayed. When the "update interval" is 1 second, the "Show tail only" function is available after around 10 minutes of data collection. The y-axis displays the measured irradiance in W/m^2 . The Y-axis automatically scales to display the full measured range.

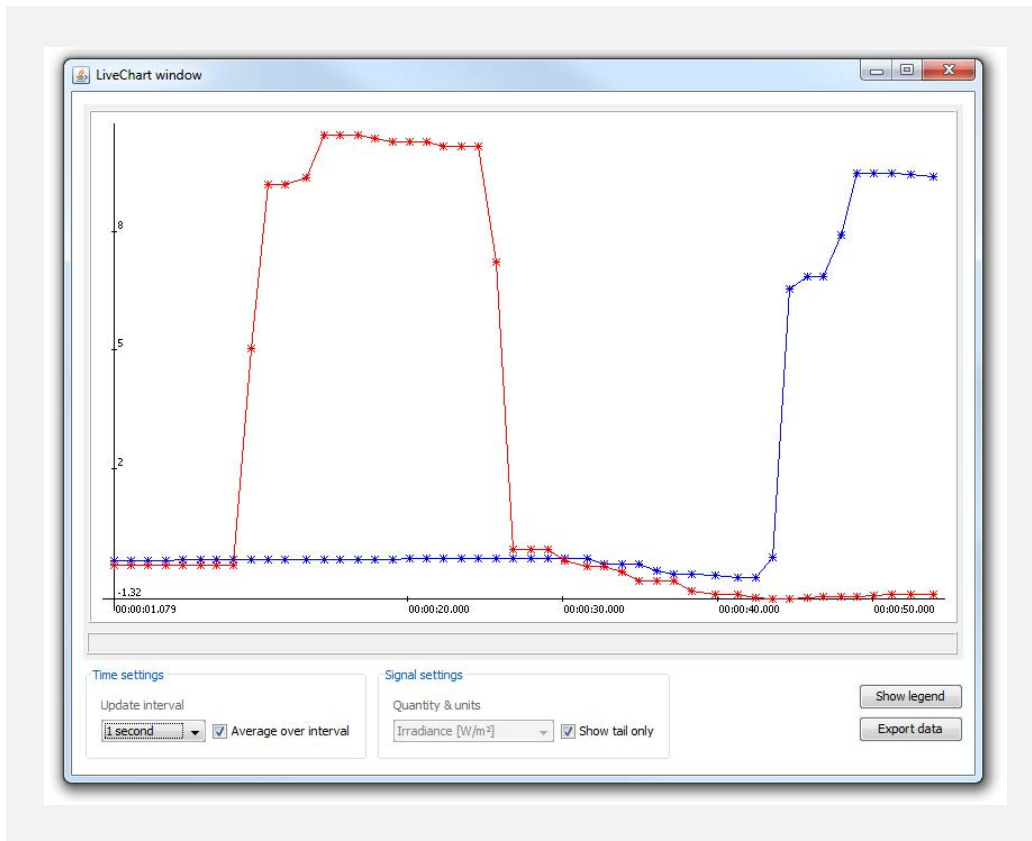

Figure 7.4.1 Example of a DR30 irradiance plot in the Sensor Manager.

7.5 Sensor Manager: information about the instrument

The main window shows the “Show details” button, giving access to the “Sensor details” window. This window displays calibration results and calibration history, temperature coefficients and other properties of the selected instrument, as shown on the next page. The sensor serial number and all calibration information should match the information on the instrument label and on the product certificate.

The “Sensor details” window shows additional measurements such as internal humidity, tilt angle and heater current, as well as the heater status. The heater status may be changed by pushing the “Heater” button. See Figure 7.5.1.1. When the button reads “On”, the heater is on, as indicated by the heater current measurement above the button. Please note: changing the status via this button in the Sensor Manager requires at least 7 VDC; besides USB (5 VDC) external power will then be needed. Alternatively, the heater may be switched on or off via a Modbus command: see Table 7.8.13 for writing to a coil.

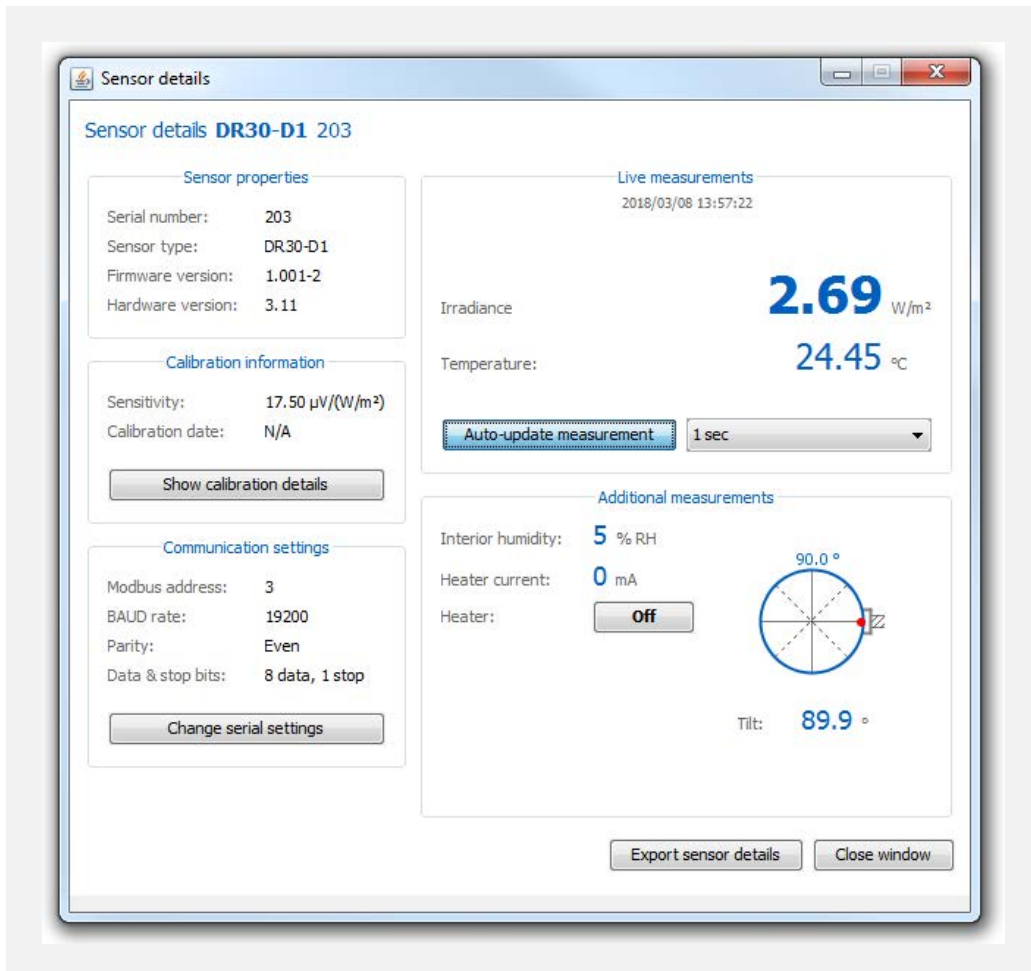

Figure 7.5.1 Sensor details window in the Sensor Manager.

7.6 Sensor Manager: changing Modbus address and communication settings

In the “Sensor details” window the “Change settings” function opens the “Change serial communication settings” window, as shown in the Figure on the next page.

When new communication settings or a new Modbus address are entered, these need to be confirmed by clicking “Change settings”. The instrument will then automatically restart. In case the “Change settings” function is not activated, the original settings remain valid. If the Modbus address is changed, the Sensor Manager will automatically reconnect with the instrument using the new address after restart.



Figure 7.6.1 Change serial communication settings window in the Sensor Manager.

7.7 Sensor Manager: adjustment of the sensitivity by power users

The Sensor Manager does not allow a “standard user” to change any settings that have a direct impact on the instrument output, i.e. the irradiance in W/m^2 . However, in case the instrument is recalibrated it is common practice that the sensitivity is adjusted, and that the latest result is added to the calibration history records. This can be done after obtaining a password and becoming a “power user”. Please contact the factory to obtain the password and to get directions to become a “power user”.

Example: During a calibration experiment, the result might be that DR30 has an irradiance output in W/m^2 that is 990, whereas the calibration reference standard indicates it should be 970. The DR30 output is in this example 2.06 % too high. The original sensitivity of $16.15 \times 10^{-6} V/(W/m^2)$ ought to be changed to 16.48, using registers 41 + 42. The old calibration result is recorded in the calibration history file. In case there are still older results these are moved over to higher register numbers 63 to 81.

7.8 Network communication: function codes, registers, coils

Warning: Using the same Modbus address for more than one device will lead to irregular behavior of the entire network. This chapter describes function codes, data model and registers used in the DR30 firmware. Communication is organized according to the specifications provided by the Modbus Organization.

These specifications are explained in the documents “Modbus application protocol v1.1b” and “Modbus over serial line v1.02”. These documents can be acquired free of charge at www.modbus.org.

Table 7.8.1 Supported Modbus function codes.

Supported modbus function codes	
function code (HEX)	description
0x01	Read Coils
0x02	Read Discrete Inputs
0x03	Read Holding Registers
0x04	Read Input Register
0x05	Write Single Coil
0x06	Write Single Holding Register
0x0F	Write Multiple Coils
0x10	Write Multiple Registers

Table 7.8.2 Modbus data model.

modbus data model		
primary tables	object type	type of
discrete input	single bit	R
coil	single bit	R/W
input register	16 bit word	R
holding register	16 bit word	R/W

R = read only, W = write only, R/W = read/write

The instrument does not distinguish between discrete input and coil; neither between input register and holding register.

Table 7.8.3 Format of data.

format of data	description
U16	Unsigned 16 bit integer
S16	Signed 16 bit integer
U32	Unsigned 32 bit integer
S32	Signed 32 bit integer
float	IEEE 754 32 bit floating point format
string	A string of ASCII characters

The data format includes *signed* and *unsigned* integers. The difference between these types is that a *signed* integer passes on negative values, which reduces the range of the integer by half. Up to five 16 bit registers can be requested in one request; if requesting six or more registers, multiple requests should be used.

If the format of data is a signed or an unsigned 32 bit integer, the first register received is the most significant word (MSW) and the second register is the least significant word (LSW). This way two 16 bit registers are reserved for a 32 bit integer. If the format of data is *float*, it is a 32 bit floating point operator and two 16 bit registers are reserved as well. Most network managing programs have standard menus performing this type of conversion. In case manual conversion is required, see the appendix on conversion of a floating point number to a decimal number. MSW and LSW should be read together in one request. This is necessary to make sure both registers contain the data of one internal voltage measurement. Reading out the registers with two different instructions may lead to the combination of LSW and MSW of two measurements at different points in time.

An Unsigned 32 bit integer can be calculated by the formula: $(MSW \times 2^{16}) + LSW = U32$. An example of such a calculation is available in the paragraph "Network communication: example master request to DR30".



Your data request may need an offset of +1 for each DR30 register number, depending on processing by the network master. Example: DR30 register number 7 + master offset = 7 + 1 = master register number 8. Consult the manual of the device acting as the local master.

Table 7.8.4 Modbus registers 0 to 31, measurements. For basic operation, Hukx recommends to read out registers 2 + 3 for solar radiation, register 6 for instrument body temperature and register 40 for the sensor serial number.services.

Modbus registers 0–31				
register number	parameter	description of content	type of	format of data
0	Modbus address	sensor address in Modbus network, default = 1	R/W	U16
1	serial communication settings	sets the serial communication, default = 5	R/W	U16
2 + 3	irradiance (temperature compensated signal)	temperature compensated signal in x 0.01 W/m ²	R	S32
4 + 5	irradiance (uncompensated signal)	uncompensated signal in x 0.01 W/m ²	R	S32
6	sensor body temperature	in x 0.01 °C	R	S16
7	sensor electrical resistance	in x 0.1 Ω	R	U16
8	scaling factor irradiance	default = 100	R	U16
9	scaling factor temperature	default = 100	R	U16
10 + 11	sensor voltage output	in x 10 ⁻⁹ V	R	S32
12 to 31	factory use only			

Register 0, Modbus address, contains the Modbus address of the sensor. This allows the Modbus master to detect the slave, DR30, in its network. The address can be changed; the value of the address must be between 1 and 247. The default Modbus address is 1. Note: The sensor needs to be restarted before this change becomes effective.

Register 1, Serial communication settings, is used to enter the settings for baud rate and the framing of the serial data transfer. Default setting is setting number 5: 19200 baud, 8 data bits, even parity and 1 stop bit. Setting options are shown in the Table below. Note: The sensor needs to be restarted before this change becomes effective.

Table 7.8.5 Setting options of register 1.

Setting options					
setting number	baud rate	databits	stopbits	parity	
1	9600	8	1	none	
2	9600	8	1	even	
3	9600	8	1	odd	
4	19200	8	1	none	
5 (= default)	19200	8	1	even	
6	19200	8	1	odd	
7	38400	8	1	none	
8	38400	8	1	even	
9	38400	8	1	odd	
10	115200	8	1	none	
11	115200	8	1	even	
12	115200	8	1	odd	

Register 2 + 3, *Irradiance (temperature compensated signal)*, provides the temperature compensated solar radiation output in 0.01 W/m². The value given must be divided by 100 to get the value in W/m². Hukx recommends using this data to achieve the highest accuracy. MSW and LSW should be read together in one request.

Register 4 + 5, *Irradiance (uncompensated signal)*. Use for comparison purposes only. Provides the sensor output in 0.01 W/m², not compensated for temperature dependence. The data must be divided by 100 to get the value in W/m². Hukx recommends not to use this data. MSW and LSW should be read together in one request.

Register 6, *Instrument body temperature*, provides the temperature of the instrument body in 0.01 °C. The data must be divided by 100 to achieve the value in °C.

Register 7, *Sensor electrical resistance*, sensor resistance in 0.1 Ω. The data needs to be divided by 10 to get the value in Ω. This register returns a 0 by default. To read the resistance, first a measurement has to be performed. This can be done by writing 0xFF00 to coil 2. Hukx recommends to use this function only when necessary for diagnostics in case of sensor failure.

Register 8, *Scaling factor irradiance*, default scaling factor is 100.

Register 9, *Scaling factor temperature*, default scaling factor is 100.

Register 10 + 11, *Sensor voltage output*, sensor voltage output signal of the thermopile in $\times 10^{-9}$ V.

Table 7.8.6 Modbus registers 32 to 62, sensor and calibration information.

register number	parameter	description of content	type of	format of data
32 to 35	sensor model	part one of sensor description	R	string
36 to 39	sensor model	part two of sensor description	R	string
40	sensor serial number		R	U16
41 + 42	sensor sensitivity	in $\times 10^{-6}$ V/(W/m ²)	R	float
43	response time	in $\times 0.1$ s	R	U16
44	sensor resistance	in $\times 0.1$ Ω	R	U16
45	reserved	always 0	R	U16
46 + 47	sensor calibration date	calibration date of the sensor in YYYYMMDD	R	U32
48 to 60	factory use		R	
61	firmware version		R	U16
62	hardware version		R	U16

Register 32 to 39, *Sensor model*, String of 8 registers. This register will return 8 numbers, which correspond with ASCII characters.

Register 40, *Sensor serial number*.

Register 41 + 42, *Sensor sensitivity*, the sensitivity of the sensor in $\times 10^{-6}$ V/(W/m²). Format of data is float.

Register 43, *Response time*, the response time of the sensor as measured in the factory in $\times 0.1$ s. The value must be divided by 10 to get the value in s.

Register 44, *Sensor electrical resistance*, returns the electrical resistance measured during the sensor calibration. The resistance is in $\times 0.1 \Omega$ and must be divided by 10 to get the value in Ω .

Register 46 + 47, *Sensor calibration date*, last sensor calibration date, from which the sensitivity in register 41 and 42 was found, in YYYYMMDD.

Register 61, Firmware version.

Register 62, Hardware version.

Table 7.8.7 Modbus registers 63 to 81, calibration history.

Modbus registers 63-81				
register number	parameter	description of content	type of	format of data
63 + 64	sensor sensitivity history 1	in $\times 10^{-6} \text{ V}/(\text{W}/\text{m}^2)$ default value is 0	R	float
65 + 66	calibration date history 1	former calibration date of the sensor in YYYYMMDD default value is 0	R	U32
67 + 68	sensor sensitivity history 2	see register 63 + 64	R	float
69 + 70	calibration date history 2	see register 65 + 66	R	U32
71 + 72	sensor sensitivity history 3	see register 63 + 64	R	float
73 + 74	calibration date history 3	see register 65 + 66	R	U32
75 + 76	sensor sensitivity history 4	see register 63 + 64	R	float
77 + 78	calibration date history 4	see register 65 + 66	R	U32
79 + 80	sensor sensitivity history 5	see register 63 + 64	R	float
81 + 82	calibration date history 5	see register 65 + 66	R	U32

Register 63 to 82: Only accessible for writing by Sensor Manager power users: power users can write calibration history to registers 63 to 82. If default values are returned, no re-calibration has been written. Last calibration sensitivity and calibration date are available in register 41 + 42 and 46 + 47 respectively.

Table 7.8.9 Modbus registers 83 to 95, temperature response characterization data.

Modbus registers 83-95				
register number	parameter	description of content	type of	format of data
83 + 84	factory use			
85	factory use			
86	temperature response	in x 0.01 %	R	S16
87 + 88	polynomial temperature coefficient a		R	float
89 + 90	polynomial temperature coefficient b		R	float
91 + 92	polynomial temperature coefficient c		R	float
93 + 94	temperature response characterization measurement date	temperature response characterization measurement date of the sensor in YYYYMMDD	R	U32
95	temperature response characterization measurement employee		R	U16

Register 83 to 95, these registers are for reference purposes.

Table 7.8.10 Modbus registers 96 to 99, humidity sensor information.

Modbus registers 96-99				
register number	parameter	description of content	type of	format of data
96 + 97	factory use			
98	humidity (RH)	In x 0.01 %	R	U16
99	humidity temperature	In x 0.01 °C	R	S16

Register 98, *humidity*, provides the relative humidity within the instrument. The value must be divided by 100 to get the value in %.

Register 99, *humidity temperature*, the temperature measured by the humidity sensor. The value must be divided by 100 to get the value in °C.

Table 7.8.11 Modbus registers 137 to 140, pressure sensor information.

Modbus registers 137-140				
register number	parameter	description of content	type of	format of data
100-136	factory use			
137	pressure	in x (1/32) mbar	R	U16
138	pressure average	in x (1/32) mbar	R	U16
139	pressure temperature	in x (1/256) °C	R	S16
140	pressure temperature average	in x (1/256) °C	R	S16

Register 137, *pressure*, provides the internal pressure of the sensor. The value must be divided by 32 to get the value in mbar.

Register 138, *pressure average*, provides the average internal pressure of the sensor. The value must be divided by 32 to get the value in mbar.

Register 139, *pressure temperature*, provides the temperature of the pressure sensor. The value must be divided by 256 to get the value in °C.

Register 140, *pressure temperature average*, provides the average temperature of the pressure sensor. The value must be divided by 256 to get the value in °C.

Table 7.8.12 Modbus registers 141 to 199, tilt sensor information.

Modbus registers 141–199				
register number	parameter	description of content	type of	format of data
141–193	factory use			
194	tilt angle	in x 0.01 °	R	U16
195	tilt angle average	in x 0.01 %	R	U16
196	factory use			
197	factory use			
198	heater current	in x 1 mA	R	U16
199	factory use			

Register 194, Tilt angle, provides the angle in ° of the z-axis in comparison to the xy-plane. In other words, Tilt angle, provides the instrument tilt angle in ° relative to zenith. The value must be divided by 100 to get the value in °.

Register 195, Tilt angle average, provides the average angle of the z-axis in comparison to the xy-plane. In other words, Tilt angle average, provides the average instrument tilt angle in ° relative to zenith. The value must be divided by 100 to get the value in °.

Register 198, Heater current, provides the current draw of the heater in mA.

Registers 196 and 199 are unused in the DR30.



Please note that if your data request needs an offset of +1 for each DR30 register number, depending on processing by the network master, this offset applies to coils as well. Consult the manual of the device acting as the local master.

Table 7.8.13 Coils.

Coils				
coil	parameter	description	type of	object type
0	restart	restart the sensor	W	single bit
1	heater	turn heater on/off	W	single bit
2	check	measure sensor electrical resistance	W	single bit
3	factory use			

Coil 0, *Restart*, when 0xFF00 is written to this coil the sensor will restart. If applied, a new Modbus address or new serial settings will become effective.

Coil 1, *Heater*, when 0xFF00 is written to this coil the heater will turn on. If 0x0000 is written the heater will turn off.

Coil 2, *Check*, when 0xFF00 is written to this coil the internal electronics will measure the electrical resistance of the thermopile. After the measurement, a new value will be written into register 7. Requesting to write this coil with a high repetition rate will result in irregular behavior of the sensor; the check must be executed as an exceptional diagnostics routine only.

7.9 Network communication: getting started

Once it has the correct Modbus address and communication settings, DR30-D1 can be connected directly to an RS-485 network and a power supply. How to physically connect a sensor as a slave in a Modbus network is shown in the Figure below. In such a connection, the sensor is powered via an external power supply of 7 to 30 VDC. When the sensor is screwed onto a grounded mounting plate, which is usually the case, the shield is not connected to ground at the cable end.

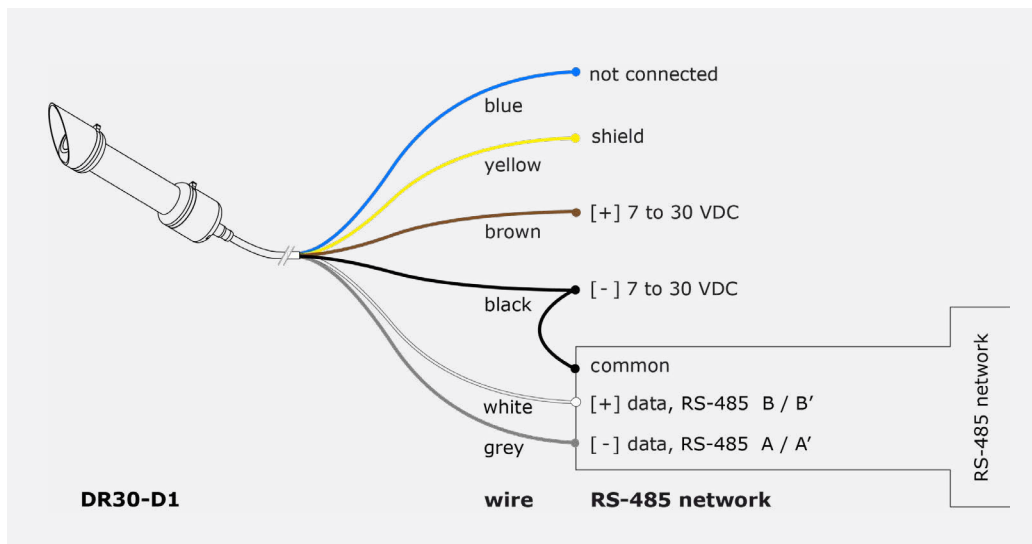

Figure 7.9.1 Connecting DR30 to a typical RS-485 network.

Installing a DR30 in the network also requires configuring the communication for this new Modbus device. This usually consists of defining a request that can be broadcast by the master. If the DR30 is not already defined as a standard sensor type on the network, contact the supplier of the network equipment to see if a library file for the DR30 is available.

Typical operation requires the master to make a request of irradiance data in registers 2 + 3, sensor temperature in register 6, and the sensor serial number in register 40 every 1 second, and store the 60 second averages. The data format of register 2 + 3 is a signed 32 bit integer and the temperature in register 6 is a signed 16 bit integer.

Up to five 16 bit registers can be requested in one request. In case six or more registers are requested in just one request, DR30 will not respond. If requesting six or more registers, multiple requests should be used: DR30 will respond as expected.

7.9.1 Adapting the Modbus address and communication settings

Setting the instrument address and baud rate can be done in different ways:

- By connecting the sensor to the PC and using the Sensor Manager.
- By connecting the sensor to the PC and using another Modbus testing tool. There are links to different solutions available at www.modbus.org
- By using the available network user interface software.

The Modbus address is stored in register 0 and has a default value of 1. A user may change the address to a value in the range of 1 to 247. The address value must be unique in the network. The communication settings are stored in register 1. The default setting is setting number 5 representing a communication with 19200 baud, even parity bit, 8 data bits and 1 stop bit. After a new address or communication setting is written the sensor must be restarted. This can be done by writing 0XFF00 to coil 0.

7.10 Network communication: example master request to DR30

Normal sensor operation consists of requesting the output of registers 2 + 3; the temperature compensated solar radiation. For quality assurance also the sensor serial number, register 40 and the temperature in register 6, are useful.

In this example, a DR30 has address 64. The example requests the solar radiation (temperature compensated) register 2 + 3, sensor serial number, register 40, and the temperature of the instrument register 6. The values are represented in hexadecimals.

Note: 32 bit data are represented in 2 registers. MSW and LSW should be read together in one request.

Request for solar radiation, register 2 + 3:

Master Request:

[40] [03] [00][00] [00][04] [4B][18]

[40] = Modbus slave address, decimal equivalent = 64

[03] = Modbus function; 03 Read holding registers

[00][00] = Starting register, the master requests data starting from register 0

[00][04] = Length, the number of registers the master wants to read. 4 registers

[4B][18] = CRC, the checksum of the transmitted data

Sensor response:

[40] [03] [08] [00][40] [00][05] [00][01] [7C][4F] [79][DA]

[40] = Modbus slave address, decimal equivalent = 64

[03] = Modbus function

[08] = Number of bytes returned by the sensor. 8 bytes transmitted by the sensor

[00][40] = Register 0; Modbus address

[00][05] = Register 1; Serial settings, 19200 baud, 8 data bits, even parity bit, 1 stop bit

[00][01] = Register 2; Temperature compensated signal,

Most Significant Word (MSW). Decimal equivalent = 1

[7C][4F] = Register 3; Temperature compensated signal,
Least Significant Word (LSW) = Decimal equivalent = 31823
[79][DA] = CRC, the checksum of the transmitted data

Together, register 2 and 3 are representing the temperature compensated solar radiation output measured by the DR30. The MSW is in register 2 and the LSW in 3. The output has to be calculated by the formula: $((MSW \times 2^{16}) + LSW)/100$. In this example the result is: $((2^{16} \times 1) + 31823)/100 = 973.59 \text{ W/m}^2$

Request for body temperature, register 6:

Master Request:

[40][03][00][06][00][01][6B][1A]

[40] = Modbus Slave address

[03] = Modbus function

[00][06] = Start register

[00][01] = Number of registers

[6B][1A] = CRC

Sensor response:

[40][03][02][08][B1][43][FF]

[40] = Modbus Slave address

[03] = Modbus function

[02] = Number of bytes

[08][B1] = Content of register 7, decimal equivalent = 2225

[43][FF] = CRC

Temperature = Register 7 x 0.01 = 2225 x 0.01 = 22.25 °C

Register 6 represents the sensors body temperature. The received data needs to be divided by 100 to represent the correct outcome.

In this example the result is: 2225 x 0.01 = 22.25 °C

Request for serial number, register 40:

Master Request:

[40][03][00][28][00][01][0B][13]

[40] = Modbus slave address

[03] = Modbus function

[00][28] = Start register

[00][01] = Number of registers

[0B][13] = CRC

Sensor response:

[40][03][02][0A][29][43][35]

[40] = Modbus Slave address

[03] = Modbus function

[02] = Number of bytes

[0A][29] = Content of register 40, decimal equivalent = 2601

[43][35] = CRC

Register 40 represents the sensors serial number. In this example the serial number is 2601.

8

Making a dependable measurement

8.1 The concept of dependability

A measurement with a pyrheliometer is called “dependable” if it is reliable, i.e. measuring within required uncertainty limits, for most of the time and if problems, once they occur, can be solved quickly.

The requirements for a measurement with a pyrheliometer may be expressed by the user as:

- required uncertainty of the measurement (see following paragraphs)
- requirements for maintenance and repairs (possibilities for maintenance and repair including the effort to be made and the processing time)
- a requirement to the expected instrument lifetime (until it is no longer feasible to repair)

It is important to realize that the uncertainty of the measurement is not only determined by the instrument, but also by the way it is used. See also ISO 9060 note 5. In case of pyrheliometers, the measurement uncertainty as obtained during outdoor measurements is a function of:

- the instrument class
- the calibration procedure/uncertainty
- the duration of instrument employment under natural sunlight (involving the instrument stability specification)
- the measurement conditions (such as tilting, ventilation, shading, instrument temperature)
- maintenance (cleaning of the window and verification of the alignment accuracy)
- the environmental conditions (such as atmospheric aerosol content, ambient air temperature, position of the sun, presence of clouds, horizon, representativeness of the location)*

Therefore, ISO 9060 says, “statements about the overall measurement uncertainty under outdoor conditions can only be made on an individual basis, taking all these factors into account”.

* Defined at Hukx as all factors outside the instrument that are relevant to the measurement such as the cloud cover (presence or absence of direct radiation), sun position, the local horizon (which may be obstructed). The environmental conditions also involve the question whether or not the measurement at the location of measurement is representative of the quantity that should be measured. For pyrheliometers the spatial distribution of circumsolar radiation, which is generated by optical scattering of direct solar radiation of the sun, may be included in uncertainty estimates. There is a contribution only in case there is a mismatch between the pyrheliometer’s acceptance function and the acceptance function defined for the measurand.

8.2 Reliability of the measurement

A measurement is reliable if it measures within required uncertainty limits for most of the time. We distinguish between two causes of unreliability of the measurement:

- Related to the reliability of the pyrheliometer and its design, manufacturing, calibration (hardware reliability).
- Related to the reliability of the measurement uncertainty (measurement reliability), which involves hardware reliability as well as condition of use.

Most of the hardware reliability is the responsibility of the instrument manufacturer. The reliability of the measurement, however, is a joint responsibility of instrument manufacturer and user. As a function of user requirements, taking into account measurement conditions and environmental conditions, the user will select an instrument of a certain class, and define maintenance support procedures.

In many situations, there is a limit to a realistically attainable accuracy level. This is due to conditions that are beyond control once the measurement system is in place. Typical limiting conditions are:

- The measurement conditions, for instance when working at extreme temperatures when the instrument temperature is at the extreme limits of the rated temperature range.
- The environmental conditions, for instance when installed at a sub-optimal measurement location with obstacles in the path of the sun.

The measurement reliability can be improved by maintenance.

Important aspects are:

- Window fouling by deposition of dust, dew, rain or snow. Fouling results in undefined measurement uncertainty (sensitivity and acceptance function are no longer defined). This should be solved by regular inspection and cleaning.
- Sensor instability. Maximum expected sensor aging is specified per instrument as its non-stability in [% change/year]. In case the sensor is not recalibrated, the uncertainty of the sensitivity gradually will increase. This is solved by regular recalibration.
- Moisture condensing under the pyrheliometer window resulting in a slow change of sensitivity (within specifications). This is solved by replacement of desiccant or by maintenance (drying the entire sensor). For pyrheliometers extra desiccant is available from the manufacturer.

Another way to improve measurement reliability is to introduce redundant sensors.

- The use of redundant instruments allows remote checks of one instrument using the other as a reference, which leads to a higher measurement reliability.
- Data can also be compared to measurements by local meteorological stations.
- DNI data can often be compared to pyranometer measurements (global irradiance and diffuse), assessing the uncertainty by looking if the totals match up.

8.3 Speed of repair and maintenance

Dependability is not only a matter of reliability, but also involves the reaction to problems; if the processing time of service and repairs is short, this contributes to the dependability.

Hukx pyrhelimeters are designed to allow easy maintenance and repair. The main maintenance actions are:

- cleaning of window
- replacement of desiccant
- replacement of cabling

For optimisation of dependability, a user should:

- Design a schedule of regular maintenance.
- Design a schedule of repair or replacement in case of defects.

When operating multiple instruments in a network Hukx recommends keeping procedures simple and having a few spare instruments to act as replacements during service, recalibrations and repair.

8.4 Uncertainty evaluation

The uncertainty of a measurement under outdoor or indoor conditions depends on many factors, see Paragraph 1 of this chapter. It is not possible to give one figure for pyrhelimeter measurement uncertainty. The work on uncertainty evaluation is “in progress”. There are several groups around the world participating in standardization of the method of calculation. The effort aims to work according to the guidelines for uncertainty evaluation (according to the “*Guide to Expression of Uncertainty in Measurement*” or GUM)^[3].

8.5 Definition of the measurand

DR30 measures direct solar radiation with an acceptance function as recommended by WMO (see also the appendix on the terminology).

In most measurements related to meteorology, solar energy resource assessment and PV system performance monitoring, the required measurand equals the DR30 measurand. In that case, the acceptance function is perfect and there is no contribution of the circumsolar radiation to the measurement uncertainty. However, in case the required measurand acceptance function is different from that recommended by WMO, for instance when estimating the input to Concentrated PV panels (CPV), this leads to additional measurement uncertainty. See the next paragraph of an idea of the order of magnitude.

8.6 Contributions from circumsolar radiation

DR30 measures by definition direct solar radiation with an acceptance function as recommended by WMO (see also the appendix on the terminology). The measurement includes a certain amount of circumsolar radiation.

Table 8.6.1 Contributions from the circumsolar radiation to the DNI measurement with a pyrheliometer with a 5 ° full field of view angle. The contribution is estimated for different aerosol types, different amounts of aerosol and different solar zenith angles. The total amount of aerosol is defined by spectral optical thickness at a wavelength of 550×10^{-9} m. Optical thicknesses are 0.05, 0.2 and 0.4 respectively. Corresponding Linke turbidity factors are 1.8, 3.4 and 5.4 respectively. Desert-type environments, not in this table, are in between urban and continental. Source: adaptation of ISO 1959:1990, Annex A, Table A1.

atmospheric aerosol		solar zenith angle	DNI from the sun solar disk only	circumsolar radiation as percentage of DNI when measured with acceptance function recommended by WMO
[type]	[amount]	[°]	[W/m ²]	[%]
urban	low	30	985	0.1
	medium		872	0.3
	high		746	0.5
	low	70	736	0.1
	medium		555	0.5
	high		389	1.2
continental (background)	low	30	979	0.4
	medium		851	0.8
	high		707	1.8
	low	70	735	0.7
	medium		514	2.4
	high		328	4.1
maritime	low	30	972	0.7
	medium		826	2.8
	high		668	5.2
	low	70	711	1.6
	medium		473	6.6
	high		275	12.9

8.7 Instrument classification, and approaches to uncertainty evaluation

The standard covering instrument specification, ISO 9060, defines pyrheliometer classification in 3 categories or classes, according to their quality of manufacture and level of quality assurance during production.

An “accuracy class” is defined according to the International Vocabulary of Metrology, VIM^[4] Paragraph 4.25, as a class of measuring instruments or measuring systems that meet stated metrological requirements that are intended to keep measurement errors or instrumental uncertainties within specified limits under specified operating conditions.

Instrument manufacturers can only supply an instrument according certain specifications, with a certain initial calibration uncertainty. They are not in control of the other factors determining the measurement uncertainty. This is the user’s own responsibility.

When making an uncertainty evaluation, the general approach is laid down in GUM. The link between the classification and GUM is specified in VIM Paragraph 2.29: a way to obtain non-statistical, type B evaluation of measurement uncertainty is “obtained from the accuracy class of a verified measuring instrument”.

A user of solar radiation sensors therefore has several options:

1. To make a full analysis according to GUM, and all local circumstances; the latter is found in the following paragraph.
2. To use a generalized uncertainty evaluation based on analogy of instrument class, calibration, maintenance and environmental conditions.

8.8 Evaluation of measurement uncertainty under outdoor conditions

Hukx actively participates in the discussions about pyrheliometer measurement uncertainty; we also provide spreadsheets, reflecting the latest state of the art, to assist our users in making their own evaluation. Application of this spreadsheet is at the user’s own risk. The input to the assessment is summarized:

1. The formal evaluation of uncertainty should be performed in accordance with ISO 98-3 *Guide to the Expression of Uncertainty in Measurement*, GUM.
2. The specifications of the instrument according to the list of ISO 9060 classification of pyranometers and pyrheliometers are entered as limiting values of possible errors, to be analyzed as type B evaluation of standard uncertainty per Paragraph 4.3.7. of GUM. A priori distributions are chosen as rectangular.
3. A separate estimate has to be entered to allow for estimated uncertainty due to the instrument maintenance level.
4. The calibration uncertainty has to be entered. Please note that Hukx calibration uncertainties are lower than those of alternative equipment.
These uncertainties are entered in measurement equation (equation is usually Formula 0.1: $E = U/S$), either as an uncertainty in E (zero offsets, directional response) in U (voltage readout errors)

or in S (tilt error, temperature dependence, calibration uncertainty).

5. In uncertainty analysis for pyrheliometers, the location and date of interest is entered. The course of the sun is then calculated, and the direct and diffuse components are estimated, based on a model.
6. In uncertainty analysis for modern pyrheliometers: tilt dependence often is so low that one single typical observation may be sufficient.
7. In case of special measurement conditions, typical specification values are chosen. These should for instance account for the measurement conditions and environmental conditions (clear sky / cloudy, working temperature range).
8. Among the various sources of uncertainty, some are "correlated"; i.e. present during the entire measurement process, and not cancelling or converging to zero when averaged over time; the off-diagonal elements of the covariance matrix are not zero. Paragraph 5.2 of GUM.
9. Among the various sources of uncertainty, some are "uncorrelated"; cancelling or converging to zero when averaged over time; the off-diagonal elements of the covariance matrix are zero. Paragraph 5.1 of GUM.
10. Among the various sources of uncertainty, some are "not included in analysis"; this applies for instance to the spectral response for pyranometers and pyrheliometers because it is already taken into account in the calibration process.
11. In case the required measurand acceptance function is different from that recommended by WMO, for instance when estimating the input to Concentrated PV panels (CPV), this leads to additional measurement uncertainty.

The following two tables show results by Hukx and WMO; the latter without entering calibration uncertainty

Table 8.8.1 Preliminary estimate of the achievable uncertainty of measurements with first class pyrheliometers. The estimate is based on typical pyrheliometer properties and a typical calibration uncertainty, for sunny, clear sky days and well maintained stations, without uncertainty loss due to lack of maintenance, circumsolar radiation and due to instrument fouling. The table specifies expanded uncertainties with a coverage factor of 2 and confidence level of 95 %. Estimates are based on 1 s sampling. IMPORTANT NOTE: there is no international consensus on uncertainty evaluation of pyrheliometer measurements, so this table should not be used as a formal reference. The uncertainty hardly shows any dependence of time of day or season. (contrary to pyranometers).The measurement around solar noon is more accurate because of the contribution of absolute uncertainty sources.

pyrheliometer class (ISO 9060)	season	AOD	uncertainty minute totals at solar noon	uncertainty hourly totals at solar noon	uncertainty daily totals
first class	summer	mid-latitude	2.8 %	2.8 %	2.9 %
		pole	2.8 %	2.8 %	2.8 %
	winter	mid-latitude	2.8 %	2.8 %	2.9 %

Table 8.8.2 Estimate of achievable uncertainties of measurements with good quality pyrheliometers according to WMO-No.-8, seventh edition, 2008. Copy from WMO Guide 7.2.1: The estimated uncertainties are based on the following assumptions: (a) Instruments are well-maintained, correctly aligned and clean; (b) 1 min and 1 h figures are for clear-sky irradiances at solar noon; (c) Daily exposure values are for clear days at mid-latitudes. **IMPORTANT NOTE:** According to 7.3.2.5 the achievable uncertainty does not include any calibration errors. **IMPORTANT NOTE:** Achievable accuracy is not part of the GUM vocabulary.

interval	achievable uncertainty
achievable uncertainty (95% confidence level) daily totals	$\pm 1.0 \%$
achievable uncertainty (95% confidence level) hourly totals	$\pm 1.5 \%$
achievable uncertainty (95% confidence level) minute totals	$\pm 1.8 \%$

8.9 Calibration uncertainty

Our latest calibration method results in an uncertainty of the sensitivity of less than 1.2 %. The user may receive an instrument with a lower uncertainty. See the calibration report for the exact value.

9 Maintenance and trouble shooting

9.1 Recommended maintenance and quality assurance

DR30 is typically used for high-accuracy measurements and cannot measure reliably at a low level of maintenance. As a general rule, this means that regular cleaning of the window and visual inspection of alignment accuracy combined with a critical review of the measured data, preferably checking against other measurements, is the preferred way to obtain a reliable measurement.

Table 9.1.1 Recommended maintenance of DR30. If possible the data analysis, tracker inspection and cleaning (1 and 2) should be done on a daily basis (continued on next page).

minimum recommended pyrheliometer maintenance			
	interval	subject	action
1	0.5 week	cleaning	Use a soft cloth to clean the window of the instrument, persistent stains can be treated with soapy water or alcohol.
		tracking	Inspect tracking and alignment, make adjustments if necessary.
2	1 week	data analysis	Compare measured data to maximum possible/ maximum expected irradiance and to other measurements nearby (redundant instruments). Also historical seasonal records can be used as a source for expected values. Analyze nighttime signals. These should be close to zero. Check for any patterns and events that deviate from what is normal or expected.
3	6 months	inspection	Inspect cable quality, inspect cable connectors, inspect mounting position, inspect cable, clean instrument, clean cable, inspect levelling, inspect mounting connection, inspect interior of window for condensation.
4	2 years	recalibration	Recalibration by side-by-side comparison to a higher standard instrument in the field according to ISO 9059.
5		lifetime assessment	Judge if the instrument should be reliable for another 2 years, or if it should be replaced.

6	> 5 years	desiccant replacement	desiccant replacement
7		parts replacement	If applicable/necessary replace the parts that are most exposed to weathering; cable, protection cap. NOTE: use Hukx approved parts only.
8		internal inspection	if applicable: open instrument and inspect/replace o-rings; dry internal cavity around the circuit board.

9.2 Trouble shooting

Table 9.2.1 Trouble shooting for DR30 (continued on next pages).

general	<p>Inspect the instrument for any damage.</p> <p>Inspect if the connector is properly attached.</p> <p>Check the condition of the connectors (on chassis as well as the cable).</p> <p>Inspect if the sensor receives DC voltage power in the range of 7 to 30 VDC.</p> <p>Inspect the connection of the shield (typically not connected at the network side).</p> <p>Inspect the connection of the sensor power supply, typically the negative is connected to the network common.</p> <p>Read out the internal humidity using the Modbus interface. If the reading is > 50% at 20 °C for at least 24 hours, the sensor may be leaking, or the desiccant may be saturated. If internal humidity is stored, look at the long-term trend.</p> <p>To investigate leakage, the user may also read out the internal pressure sensor and see if the internal pressure correlates with body temperature (this is a sign that the construction is closed) or not.</p> <p>Please contact the factory to discuss diagnostics and possible action.</p>
Prepare for indoor testing.	<p>Install the Sensor Manager software on a PC. Equip the PC with RS-485 communication. Put DC voltage power to the sensor and establish communication with the sensor. At power-up the signal may have a temporary output level different from zero; an offset. Let this offset settle down.</p>
The sensor does not give any signal.	<p>Verify that the solar tracker operates normally and the instrument is properly aligned. Verify that the sensor has an unobstructed line of sight to the sun.</p> <p>Check if the sensor reacts to light: expose the sensor to a strong light source, for instance a 100 W light bulb at 0.1 m distance. The signal should read > 100 W/m² now. Darken the sensor either by putting something over it or switching off the light. The instrument voltage output should go down and within one minute approach 0 W/m². Check the data acquisition by replacing the sensor with a spare sensor with the same address.</p>

Not able to communicate with the sensor.

Check all physical connections to the sensor and try connecting to the sensor again. If communicating is not possible, try to figure out if the address and communication settings are correct. Analyze the cable performance by measuring resistance from pins to cable ends. The electrical resistance should be $< 10 \Omega$. In case of doubt, try a new cable.

Connect sensor to a PC and perform the "Find First" and "Find All" operation with the Sensor Manager to locate the sensor and verify the communication settings. If all physical connections are correct, and the sensor still cannot be found, please contact the factory to send the sensor to the manufacturer for diagnosis and service.

DR30 does not respond to a request for 6 or more registers.

It is not possible to request more than five 16 bit registers in one request. In case of requesting six or more registers in just one request, the sensor will not respond. If requesting six or more registers, use multiple requests: the sensor will respond as expected.

The sensor signal is unrealistically high or low.

Note that night-time signals may be negative due to zero offset a.

Check if the pyrhelimeter has a clean window.

Check the tracking accuracy in the presence of sun. The dot projected by the sight on the target hole should be no more than 100 % off target (the dot has a 1.5×10^{-3} m diameter, the target hole also has a 1.5×10^{-3} m diameter; 100 % off target means that the dot is projected outside the target hole).

Check programming in your data acquisition system.

The sensor signal shows unexpected variations.

Check the presence of strong sources of electromagnetic radiation (radar, radio).

Check the condition and connection of the shield.

Check the condition of the sensor cable.

Check if the cable is not moving during the measurement.

Check the condition of the connectors (on chassis as well as the cable).

The instrument shows internal condensation.

Arrange to send the sensor to the manufacturer for diagnosis and service.

9.3 Calibration and checks in the field

Recalibration of field pyrheliometers is typically done by comparison in the field to a reference pyrheliometer. The applicable standard is ISO 9059 "Solar Energy — Calibration of field pyrheliometers by comparison to a reference pyrheliometer".

At Hukx an indoor calibration according to the same standard is used.

In case of field comparison; ISO allows use of sensors of the same class.

Hukx recommends also using the same model, because an intercomparison of similar instruments has the advantage that they suffer from the same offsets and contributions of circumsolar radiation.

ISO recommends to perform field calibration during several days; 2 to 3 days under cloudless conditions. In order to limit the influence of turbidity and aerosols Hukx suggests to using hourly totals near solar noon.

Hukx main recommendations for field intercomparisons are:

1. To take high solar irradiance measurements at solar noon as a reference and not the entire day.
2. To take a reference of the same brand and type as the field pyrheliometer or a pyrheliometer of a higher class.
3. To connect both to the same electronics, so that electronics errors (also offsets) are eliminated.
4. To mount all instruments on the same tracker.
5. To correct deviations of more than $\pm 0.2\%$. Lower deviations should be interpreted as acceptable and should not lead to a revised sensitivity.

9.4 Data quality assurance

Quality assurance can be done by:

- Analyzing trends in solar irradiance signal.
- Plotting the measured irradiance against mathematically generated expected values.
- Comparing irradiance measurements between sites.
- Analysis of nighttime signals.

The main idea is that one should look out for any unrealistic values.

See for example:

C.N. Long and Y. Shi, [An Automated Quality Assessment and Control Algorithm for Surface Radiation Measurements](#), The Open Atmospheric Science Journal, 2008, 2: pp. 23–37.

10 Appendices

10.1 Appendix on cable extension/replacement

The sensor cable of DR30 is equipped with a M12-A straight connector. In case of cable replacement, it is recommended to purchase a new cable with connector at Hukx. In case of cable extension, it is recommended to purchase an extension cable with connector pair at Hukx. Please note that Hukx does not provide support for Do-It-Yourself connector and cable assembly.

DR30 is equipped with one cable. Maximum length of the sensor cable depends on the RS-485 network topology applied in the field. In practice, daisy chain topologies or point to point (PtP) topologies are used. The length of the sensor cable should be as short as possible to avoid signal reflections on the line, in particular in daisy chain configurations. In point to point configurations cable lengths can in theory be much longer; RS-485 is specified for cable lengths up to 1200 meters.

Connector, cable and cable connection specifications are summarized below.

Table 10.1.1 Preferred specifications for cable extension of DR30.

general replacement	Please order a new cable with connector at Hukx.
general cable extension	Please order an extension cable with connector pair at Hukx.
connectors used	chassis: M12-A straight male connector, male thread, 5-pole manufacturer: Binder cable: M12-A straight female connector, female thread, 5-pole manufacturer: Binder The shield is electrically connected to the connector housing.
cable	5-wire, shielded manufacturer: Binder
length	Cables should be kept as short as possible, in particular in daisy chain topologies. In point to point topologies cable length should not exceed RS-485 specifications of maximum 1200 meters.
outer jacket	with specifications for outdoor use (for good stability in outdoor applications)

10.2 Appendix on tools for DR30

Table 10.2.1 Specifications of tools for DR30.

Tooling required for window assembly and backside fixation and removal.	hex key 2.5 mm
Tooling required for desiccant holder fixation and removal.	torx TX 8; please contact the factory for detailed instructions

10.3 Appendix on spare parts for DR30

- cable for DR30, with female M12-A connector at sensor end, pigtails of 0.15 m and conductors with ferrules (5, 10, 20 m). Specify cable length
- cable extension for DR30, 20 m length, with male and female M12-A connectors (order number C07E-20)
- desiccant for DR30 (silica gel, 3 x 1 g, in an HDPE bag)
- o-ring front cap 34.65 x 1.78
- o-ring back cap 40 x 2

NOTE: Glass window, thermopile sensor and internal sensors of DR30 cannot be supplied as spare parts. In case of damage to the DR30, after repair the instrument must be tested to verify performance within specification limits. This is required by ISO 9060. Testing involves verification of the temperature response and response time after thermal sensor replacement.

10.4 Appendix on standards for classification and calibration

Both ISO and ASTM have standards on instrument classification and methods of calibration. The World Meteorological Organization (WMO) has largely adopted the ISO classification system.

Table 10.4.1 Pyrheliometer standardization in ISO and ASTM.

Standards on instrument classification and calibration	
ISO standard	equivalent ASTM standard
<p>ISO 9060:1990 <i>Solar energy — Specification and classification of instruments for measuring hemispherical solar and direct solar radiation</i></p>	<p>not available comment: work is in progress on a new ASTM equivalent standard</p>
<p>Comment: a standard "<i>Solar energy — Methods for testing pyranometer and pyrheliometer characteristics</i>" has been announced in ISO 9060 but is not yet implemented.</p>	<p>not available</p>
<p>ISO 9846:1993 <i>Solar energy — Calibration of a pyranometer using a pyrheliometer</i></p>	<p>ASTM G167-15 <i>Standard Test Method for Calibration of a Pyranometer Using a Pyrheliometer</i></p>
<p>ISO 9847:1992 <i>Solar energy — Calibration of field pyranometers by comparison to a reference pyranometer</i></p>	<p>ASTM E824-10 <i>Standard Test Method for Transfer of Calibration from Reference to Field Radiometers</i></p> <p>ASTM G207-11 <i>Standard Test Method for Indoor Transfer of Calibration from Reference to Field Pyranometers</i></p>
<p>ISO 9059:1990 <i>Solar energy — Calibration of field pyrheliometers by comparison to a reference pyrheliometer</i></p>	<p>ASTM E816-15 <i>Standard Test Method for Calibration of Pyrheliometers by Comparison to Reference Pyrheliometers</i></p>

10.5 Appendix on calibration hierarchy

The World Radiometric Reference (WRR) is the measurement standard representing the SI unit of irradiance. Use of WRR is mandatory when working according to the standards of both WMO and ISO. ISO 9874 states under Paragraph 1.3: the methods of calibration specified are traceable to the WRR. The WMO manual states under Paragraph 7.1.2.2: the WRR is accepted as representing the physical units of total irradiance.

The worldwide homogeneity of the meteorological radiation measurements is guaranteed by the World Radiation Center in Davos Switzerland, by maintaining the World Standard Group (WSG) which materializes the World Radiometric Reference.

See www.pmodwrc.ch

The Hukx standard is traceable to an outdoor WRR calibration. During the outdoor calibration the sun is typically at 20 to 60 ° zenith angle, and the total irradiance at a 700 to 900 W/m² level.

Table 10.5.1 Calibration hierarchy for pyrheliometers.

Working standard calibration at pmod/wrc davos

Calibration of working standard pyrheliometers:

Method: ISO 9059, outdoor. This working standard has an uncertainty "uncertainty of standard".

The working standard has been calibrated under certain "test conditions of the standard".

The working standard has traceability to WRR world radiometric reference.

Correction of (working) standard calibration to standardized reference conditions

Correction from "test conditions of the standard" to "reference conditions" i.e. to horizontal position and 20 °C, using known (working) standard pyrheliometer properties: non-linearity, offsets, temperature dependence). This correction has an uncertainty; "uncertainty of correction".

At Hukx we call the working standard pyrheliometer "standard".

Indoor product calibration

Calibration of product, i.e. pyrheliometers:

Method: Calibration according to Hukx internal procedure DRC02.

This method employs solar radiation generated by a lamp source.

This calibration has an uncertainty associated with the method.

Calibration uncertainty evaluation

ISO 98-3 Guide to the Expression of Uncertainty in Measurement, GUM Determination of combined expanded uncertainty of calibration of the product, including uncertainty of the working standard, uncertainty of correction, uncertainty of the method (transfer error). The coverage factor must be determined; at Hukx we work with a coverage factor $k = 2$.

10.6 Appendix on requirements for solar tracking

For a correct measurement the DR30 should be pointed at the sun. It is usually mounted on a solar tracker. Theoretically the alignment accuracy of a pyr heliometer should be better than the slope angle minus the full angle of the solar disk, i.e. within 0.5° . However, in practice a wider misalignment interval may be tolerated. ISO 9059:1990 Paragraph 5.3.2 specifies that a misalignment of the slope angle minus 0.25° is permitted. With Hukx pyr heliometers, that would allow 0.75° pointing error, which is rounded off to $< 0.7^\circ$. An independent simulation in the BSRN operations manual (Figure 4.7) indicates that a pointing error of $< 0.7^\circ$ does not lead to significant measurement errors.

During production at the factory, the optical axis of the pyr heliometer is aligned with its sights. In outdoor operation the tracker is on its turn aligned along the zenith axis with its own level, and in the azimuth direction with the pyr heliometer sights. The latter is typically done using the sun as a source. The resolution (i.e. the ability to meaningfully distinguish between measurement results) of the DR30 sights is 0.2° . This means that if the pyr heliometer sight is used as a reference, the tracking accuracy should remain within 0.5° .

Hukx therefore specifies a rated misalignment interval (i.e. without impact on pyr heliometer measurement accuracy) of $\pm 0.5^\circ$ from the sun center using the pyr heliometer sight as a reference.

Some trackers employ active control with a sun sensor:

The BSRN operations manual in 2.2.1.1 recommends a tracker with a 4-quadrant sun sensor. The tracker accuracy is recommended to be $< 0.1^\circ$. However, this is not a requirement for pyr heliometers, which can operate with a 0.75° pointing error or a 0.5° detectable misalignment. Verbal communication with the editor of the BSRN manual, B. Forgan, in October 2015 confirmed that the specified tracking accuracy is a requirement for operation of sun photometers. The BSRN manual will be adapted to correct this mistake.

In case a sun sensor is used, this sensor typically controls tracking as soon as the direct solar irradiance is above a certain level. In that case, the pyr heliometers should be aligned with the sun sensor, and the rated solar tracking range, defined for passive tracking based on calculation, may be relaxed. In case we use a sun sensor with $< 0.1^\circ$ misalignment, this is much better than required for pyr heliometers. Please note that sun sensors must be regularly cleaned to be dependable. The 4-quadrant type sun sensor also needs regular recalibration to make sure that the individual drift of the 4 quadrants is compensated for.

10.7 Appendix on meteorological radiation quantities

A pyrliometer measures irradiance. The time integrated total is called radiant exposure. In solar energy radiant exposure is often given in $W \cdot h/m^2$.

Table 10.71 Meteorological radiation quantities as recommended by WMO (additional symbols by Hukx Thermal Sensors). POA stands for Plane of Array irradiance. The term originates from ASTM and IEC standards.

symbol	description	calculation	units	alternative expression	
E_{\downarrow}	downward irradiance	$E_{\downarrow} = E_{g\downarrow} + E_{l\downarrow}$	W/m^2		
H_{\downarrow}	downward radiant exposure for a specified time interval	$H_{\downarrow} = H_{g\downarrow} + H_{l\downarrow}$	J/m^2	$W \cdot h/m^2$	change of units
E_{\uparrow}	upward irradiance	$E_{\uparrow} = E_{g\uparrow} + E_{l\uparrow}$	W/m^2		
H_{\uparrow}	upward radiant exposure for a specified time interval	$H_{\uparrow} = H_{g\uparrow} + H_{l\uparrow}$	J/m^2	$W \cdot h/m^2$	change of units
E	direct solar irradiance normal to the apparent solar zenith angle		W/m^2	DNI	Direct Normal Irradiance
E_0	solar constant		W/m^2		
$E_{g\downarrow h}$	global irradiance; hemispherical irradiance on a specified, in this case, horizontal surface*	$E_{g\downarrow} = E \cdot \cos \theta_h + E_{d\downarrow}$	W/m^2	GHI	Global Horizontal Irradiance
$E_{g\downarrow t}$	global irradiance; hemispherical irradiance on a specified, in this case, tilted surface*	$E_{g\downarrow} = E \cdot \cos \theta_t + E_{d\downarrow t} + E_{l\uparrow t}$ ***	W/m^2	POA	Plane of Array irradiance
$E_{d\downarrow}$	downward diffuse solar radiation		W/m^2	DHI	Diffuse Horizontal Irradiance
$E_{l\uparrow}, E_{l\downarrow}$	upward/downward longwave irradiance		W/m^2		
$E_r\uparrow$	reflected solar irradiance		W/m^2		
E^*	net irradiance	$E^* = E_{\downarrow} - E_{\uparrow}$	W/m^2		
T_{\downarrow}	apparent surface temperature**		$^{\circ}C$ or K		
T_{\uparrow}	apparent sky temperature**		$^{\circ}C$ or K		
SD	sunshine duration		h		

θ is the apparent solar zenith angle θ_h relative to horizontal, θ_t relative to a tilted surface
g = global, l = long wave, t = tilted *, h = horizontal*

* distinction horizontal and tilted from Hukx,
** T symbols introduced by Hukx,
*** contributions of $E_{d\downarrow t}$ and $E_{l\uparrow t}$ are $E_{d\downarrow}$ and $E_{l\uparrow}$ both corrected for the tilt angle of the surface

10.8 Appendix on ISO and WMO classification tables

Table 10.8.1 Classification table for pyrheliometers per ISO 9060 and WMO.

NOTE: WMO specification of response time, zero offset, non-stability and spectral selectivity are different from that of ISO. WMO does not specify a second class or moderate quality pyrheliometer. Hukx conforms to the ISO limits. WMO also specifies achievable accuracies. ISO finds this not to be a part of the classification system because it also involves calibration. Please note that WMO achievable accuracies are for clear days at mid latitudes and that the uncertainty estimate does not include uncertainty due to calibration*.

ISO classification** table			
ISO class	Secondary standard	First class	Second class
specification limit			
response time (95 %)	15 s	20 s	30 s
zero offset (response to 5 K/h in ambient temperature)	$\pm 1 \text{ W/m}^2$	$\pm 3 \text{ W/m}^2$	$\pm 6 \text{ W/m}^2$
non stability (change per year)	$\pm 0.5 \%$	$\pm 1 \%$	$\pm 2 \%$
non linearity (100 to 1000 W/m^2)	$\pm 0.2 \%$	$\pm 0.5 \%$	$\pm 2 \%$
spectral selectivity (350 to 1500 $\times 10^{-9} \text{ m}$)	$\pm 0.5 \%$	$\pm 1 \%$	$\pm 5 \%$
temperature response (interval of 50 K)	$\pm 1 \%$	$\pm 2 \%$	$\pm 10 \%$
tilt response (0 to 90 ° at 1000 W/m^2)	$\pm 0.2 \%$	$\pm 0.5 \%$	$\pm 2 \%$
traceability: maintained by periodic comparison	with primary standard pyrheliometer	with secondary standard pyrheliometer or better	with a first class pyrheliometer or better
full field of view angle (recommended)	5 °	5 °	5 °
slope angle (recommended)	1 °	1 °	1 °

iso tracking recommendations**

rated non-alignment interval (without impact on measurement accuracy) for 1 ° slope angle	< 0.75 ° from the sun center	< 0.75 ° from the sun center	< 0.75 ° from the sun center
---	------------------------------	------------------------------	------------------------------

conformity testing***

ISO 9060	individual instrument only: all specs must comply may be qualified as primary standard	group compliance	group compliance
----------	--	------------------	------------------

Additional WMO specifications (deviating from iso 9060)

WMO class	high quality	good quality	moderate quality
WMO: response time (95 %)	15 s	30 s	
WMO: spectral selectivity (300 to 3 000 x 10 ⁻⁹ m)	± 0.5 %	± 1%	not applicable
WMO: zero offset (response to 5 K/h in ambient temperature)	± 2 W/m ²	± 4 W/m ²	not applicable
WMO: non stability (change per year)	± 0.1%	± 0.5 %	not applicable
WMO: achievable accuracy for daily sums*	± 0.5 %	± 1.0 %	not applicable
WMO: achievable accuracy for hourly sums*	± 0.7 %	± 1.5 %	not applicable
WMO: achievable accuracy for minute sums*	± 0.9 %	± 1.8 %	not applicable
WMO: resolution (smallest detectable change)	± 0.51 W/m ²	± 1 W/m ²	not applicable

* WMO 7.2.1: The estimated uncertainties are based on the following assumptions: (a) instruments are well-maintained, correctly aligned and clean; (b) 1 min and 1 h figures are for clear-sky irradiances at solar noon; (c) daily exposure values are for clear days at mid-latitudes. WMO 7.3.2.5: Table 7.5 lists the expected maximum deviation from the true value, excluding calibration errors.

** ISO 9059 *Solar energy — Calibration of field pyrheliometers by comparison to a reference pyrheliometer* Paragraph 5.3.2 allows slope angle

minus 0.25 °, which is rounded off to 0.7 °.

See also Paragraph 2.1 on requirements for tracking.

*** An instrument is subject to conformity testing of its specifications. Depending on the classification, conformity compliance can be proven either by group or individual compliance. A specification is fulfilled if the mean value of the respective test result does not exceed the corresponding limiting value of the specification for the specific category of instrument.

10.9 Appendix on the definition of pyrheliometer specifications

Table 10.9.1 Definition of pyrheliometer specifications.

specification	definition	source
response time (95 %)	Time for 95 % response. The time interval between the instant when a stimulus is subjected to a specified abrupt change and the instant when the response reaches and remains within specified limits around its final steady value. The response time is a measure of the thermal inertia inherent in the stabilization period for a final reading.	ISO 9060:1990 WMO 1.6.3
zero offset: (5 K/h in ambient temperature)	Response to 5 K/h change in ambient temperature. Zero offsets are a measure of the stability of the zero-point.	ISO 9060:1990
non-stability (change per year)	Percentage change in sensitivity per year. The dependence of sensitivity resulting from ageing effects which is a measure of the long-term stability.	ISO 9060:1990
non-linearity (100 to 1000 W/m ²)	Percentage deviation from the sensitivity at 500 W/m ² due to the change in irradiance within the range of 100 W/m ² to 1000 W/m ² . Non-linearity has an overlap with directional response, and therefore should be handled with care in uncertainty evaluation.	ISO 9060:1990
spectral selectivity (350 to 1500 x 10 ⁻⁹ m) (WMO 300 to 3000 x 10 ⁻⁹ m)	Percentage deviation of the product of spectral absorptance and spectral transmittance from the corresponding mean within the specified spectral range. Spectral selectivity is a measure of the spectral selectivity of the sensitivity.	ISO 9060:1990
temperature response (interval of 50 K)	Percentage deviation of the sensitivity due to change in ambient temperature within an interval of 50 K the temperature of the pyrheliometer body.	ISO 9060:1990
tilt response (0 ° to 90 ° at 1000 W/m ²)	Percentage deviation from the sensitivity at 0 ° tilt (horizontal) due to change in tilt from 0 ° to 90 ° at 1000 W/m ² irradiance. Tilt response describes changes of the sensitivity due to changes of the tilt angle of the receiving surface.	ISO 9060:1990
sensitivity	The change in the response of a measuring instrument divided by the corresponding change in the stimulus.	WMO 1.6.3
spectral range	The spectral range of radiation to which the instrument is sensitive. For a normal pyrheliometer this should be in the 0.3 to 3 x 10 ⁻⁶ m range. Some pyrheliometers with colored glass windows have a limited spectral range.	Hukx

full field of view angle	Also opening angle: twice the angle between the center of the sensor and the view limiting front aperture, $2 \arctan (r_a/L)$ with r_a the radius of the aperture at the front window and L the distance sensor to aperture.	Hukx / ISO 9060:1990
slope angle	The angle from the sensor edge to the view limiting front aperture at the same side, $\arctan [(r_a - r_s)/L]$ with r_a the radius of the aperture, r_s the radius of the sensor, and L the distance sensor to aperture.	Hukx / ISO 9060:1990
limit angle	The angle from the sensor edge to the view limiting front aperture at the opposite side. (ref: IEA SHC #46 and EU FP7 MACC-II projects, published by Blanc et al. 2014).	Hukx / ISO 9060:1990

10.10 Appendix on terminology/glossary

Table 10.10.1 Definitions and references of used terms.

term	definition (reference)
solar energy or solar radiation	Solar energy is the electromagnetic energy emitted by the sun. Solar energy is also called solar radiation and shortwave radiation. The solar radiation incident on the top of the terrestrial atmosphere is called extraterrestrial solar radiation; 97 % of which is confined to the spectral range of $(290 \text{ to } 3\,000) \times 10^{-9} \text{ m}$. Part of the extraterrestrial solar radiation penetrates the atmosphere and directly reaches the earth's surface, while part of it is scattered and/or absorbed by the gas molecules, aerosol particles, cloud droplets and cloud crystals in the atmosphere. The former is the direct component, the latter is the diffuse component of the solar radiation. (ref: WMO, Hukx).
hemispherical solar radiation	Solar radiation received by a plane surface from a 180° field of view angle (solid angle of $2\pi \text{ sr}$) (ref: ISO 9060).
global solar radiation	The solar radiation received from a 180° field of view angle on a horizontal surface is referred to as global radiation. Also called GHI. This includes radiation received directly from the solid angle of the sun's disc, as well as diffuse sky radiation that has been scattered in traversing the atmosphere (ref: WMO). Hemispherical solar radiation received by a horizontal plane surface (ref: ISO 9060).
Plane of Array irradiance	Also POA: hemispherical solar irradiance in the plane of a PV array (ref: ASTM E2848-13 / IEC 61724).
direct solar radiation	Radiation received from a small solid angle centered on the sun's disc, on a given plane (ref: ISO 9060).
terrestrial or longwave radiation	Radiation not of solar origin but of terrestrial and atmospheric origin and having longer wavelengths ($3\,000 \text{ to } 100\,000 \times 10^{-9} \text{ m}$). In case of downwelling E_{\downarrow} , also the background radiation from the universe is involved, passing through the "atmospheric window". In case of upwelling E_{\uparrow} , composed of longwave electromagnetic energy emitted by the earth's surface and by the gases, aerosols and clouds of the atmosphere; it is also partly absorbed within the atmosphere. For a temperature of 300 K, 99.99 % of the power of the terrestrial radiation has a wavelength longer than $3\,000 \times 10^{-9} \text{ m}$ and about 99 % longer than $5\,000 \times 10^{-9} \text{ m}$. For lower temperatures, the spectrum shifts to longer wavelengths (ref: WMO).
World Radiometric Reference (WRR)	Measurement standard representing the SI unit of irradiance with an uncertainty of less than $\pm 0.3 \%$ (see the WMO <i>Guide to Meteorological Instruments and Methods of Observation</i> , 1983, subclause 9.1.3). The reference was adopted by the World Meteorological Organization (WMO) and has been in effect since 1 July 1980 (ref: ISO 9060).

albedo	Ratio of reflected and incoming solar radiation. Dimensionless number that varies between 0 and 1. Typical albedo values are: < 0.1 for water, from 0.1 for wet soils to 0.5 for dry sand, from 0.1 to 0.4 for vegetation, up to 0.9 for fresh snow.
angle of incidence	Angle of radiation relative to the sensor measured from normal incidence (varies from 0 to 90 °).
zenith angle	Angle of incidence of radiation, relative to zenith. Equals angle of incidence for horizontally mounted instruments.
azimuth angle	Angle of incidence of radiation, projected in the plane of the sensor surface. Varies from 0 to 360 °. 0 ° is by definition the cable exit direction, also called north, east is +90 ° (ASTM G113-16).
sunshine duration	Sunshine duration during a given period is defined as the sum of that sub-period for which the direct solar irradiance exceeds 120 W/m ² (ref: WMO).

The IEA SHC #46 and EU FP7 MACC-II projects (Blanc et al. 2014) concluded that the ISO and WMO definitions are insufficiently clear and suggest the following new and refined definitions:

Table 10.10.2 Proposed new and not yet formally accepted pyrheliometer-related definitions as suggested by IEA SHC #46 and EU FP7 MACC-II projects, published by Blanc et al. 2014, compared to ISO and WMO.

term	proposed new definition (reference)
pyrheliometer	Radiometer designed for measuring the irradiance which results from the solar radiant flux from a well-defined solid angle the axis of which is perpendicular to the plane receiver surface (ref: WMO).
pyrheliometer	A radiometer designed to measure DNI (i.e. including some circumsolar irradiance). Recommended parameters for the view-limiting geometry are a full opening angle of 5 °, and a slope angle of 1 °, and therefore a limit angle of 4 ° (ref: Blanc et al. 2014).
direct solar radiation	DNI, the solar radiant flux collected by a plane unit surface normal to the axis pointing towards the center of the sun, within an optical angular aperture. This aperture is characterized by an acceptance function (ref: Blanc et al. 2014).

direct solar radiation	Radiation received from a small solid angle centered on the sun's disc, on a given plane (ref: ISO 9060).
direct solar radiation from the sun	DNI from the sun, the solar radiant flux collected by a plane unit surface normal to the axis pointing towards center of the sun, within the extent of the solar disk only (half-angle $S = 0.266^\circ \pm 1.7\%$), with a perfect radially symmetric rectangular acceptance function (ref: Blanc et al. 2014).
acceptance function	The acceptance function of an optical angular aperture: the fraction of the total radiant flux that is collected by an optical angular aperture, as a function of the off-axis angles. The geometrically perfect acceptance function is equal to one up to the slope angle, and equals zero for off-axis angles larger than the limit angle (ref: Blanc et al. 2014).
pyrheliometer acceptance function	The acceptance function of a pyrheliometer: the fraction of the total radiant flux that is collected by the combination of sensor and optical angular aperture, as a function of the off-axis angles (ref: Blanc et al. 2014).
opening angle	Also full field of view angle: twice the angle between the center of the sensor and the view limiting front aperture (ref: Blanc et al. 2014).
limit angle	The angle from the sensor edge to the view limiting front aperture at the opposite side (ref: Blanc et al. 2014).
slope angle	The angle from the sensor edge to the view limiting front aperture at the same side (ref: Blanc et al. 2014).

10.11 Appendix on literature references

1. Blanc et al. (2014) **Direct normal irradiance related definitions and applications; the circumsolar issue**, *Solar Energy*, Volume December 2014, pp. 561–577.
2. ISO (1990), ISO 9060 *Solar energy — Specification and classification of instruments for measuring hemispherical solar and direct solar radiation*, first edition.
3. ISO / IEC (1995), **GUIDE 98-3 Uncertainty of measurement — Part 3: Guide to the expression of uncertainty in measurement (GUM:1995)**, also published as JCGM 100:2008, published on internet, accessed 15 JAN, 2014.
4. JCGM (2008), JCGM 200:2008 **International vocabulary of metrology — Basic and general concepts and associated terms (VIM)**, published on internet, accessed 15 JAN, 2014.

10.12 Appendix on floating point format conversion

For efficient use of microcontroller capacity some registers in the DR30 contain data in a float or floating point format. In fact, a floating point is an approximation of a real number represented by a number of significant digits (mantissa) and an exponent. For implementation of the floating point numbers, Hukx follows the IEEE 754 standard. In this example, the floating point of register 41 and 42 is converted to the decimal value it represents. In the Sensor Manager software and other Modbus tools, floating point data will be converted to decimal data automatically.

Example of the calculation of register 41 + 42 representing a floating point for the sensitivity of the sensor, which is 15.14:

Data in register 41, 16754 (MSW)

Data in register 42, 15729 (LSW)

Double word:

$$(\text{MSW} \times 2^{16}) + \text{LSW} \quad \text{so: } (16754 \times 2^{16}) + 15729 = 1098005873$$

According to IEEE 754:

Sign bit:

$$1098005873 < 2147483647 \quad \text{so: sign bit} = 1;$$

The number 2147483647 is defined by IEEE 754

Exponent:

$$1098005873 / 2^{23} = 130 \text{ (digits after the decimal point are ignored)}$$

$$130 - 127 = 3 \quad \text{so: exponent} = 3;$$

The number 127 is a constant defined by IEEE 754

Mantissa:

$$130 \times 2^{23} = 1090519040$$

$$1098005873 - 1090519040 = 7486833$$

$$7486833 / 2^{23} = 0.8925$$

According to IEEE 754, 1 has to be added to get mantissa

$$0.8925 + 1 = 1.8925 \quad \text{so: mantissa} = 1.8925$$

Calculation of floating point:

$$\text{float} = \text{sign bit} \times \text{mantissa} \times (2^{\text{exponent}}) = 1 \times 1.8925 \times 2^3 = 15.14$$

$$\text{so: floating point} = 15.14$$

10.13 Appendix on function codes, register and coil overview

Table 10.13.1 Supported Modbus function codes.

function code (hex)	description
0x01	Read Coils
0x02	Read Discrete Inputs
0x03	Read Holding Registers
0x04	Read Input Register
0x05	Write Single Coil
0x06	Write Single Holding Register
0x0F	Write Multiple Coils
0x10	Write Multiple Registers



Your data request may need an offset of +1 for each DR30 register number, depending on processing by the network master. Example: DR30 register number 7 + master offset = 7 + 1 = master register number 8. Consult the manual of the device acting as the local master.

Table 10.13.2 Modbus registers 0 to 199.

Modbus registers 0-199				
register number	parameter	description of content	type of	format of data
0	Modbus address	sensor address in Modbus network, default = 1	R/W	U16
1	serial communication settings	sets the serial communication, default = 5	R/W	U16
2 + 3	irradiance (temperature compensated signal)	temperature compensated signal in x 0.01 W/m ²	R	S32
4 + 5	irradiance (uncompensated signal)	uncompensated signal in x 0.01 W/m ²	R	S32
6	sensor body temperature	in x 0.01 °C	R	S16

7	sensor electrical resistance	in x 0.1 Ω	R	U16
8	scaling factor irradiance	default = 100	R	U16
9	scaling factor temperature	default = 100	R	U16
10 + 11	sensor voltage output	in x 10 ⁻⁹ V	R	S32
12 to 31	factory use only			
32 to 35	sensor model	part one of sensor description	R	string
36 to 39	sensor model	part two of sensor description	R	string
40	sensor serial number		R	U16
41 + 42	sensor sensitivity	in x 10 ⁻⁶ V/(W/m ²)	R	float
43	response time	in x 0.1 s	R	U16
44	sensor resistance	in x 0.1 Ω	R	U16
45	reserved	always 0	R	U16
46 + 47	sensor calibration date	calibration date of the sensor in YYYYMMDD	R	U32
48 to 60	factory use		R	
61	firmware version		R	U16
62	hardware version		R	U16
63 + 64	sensor sensitivity history 1	in x 10 ⁻⁶ V/(W/m ²) default value is 0	R	float
65 + 66	calibration date history 1	former calibration date of the sensor in YYYYMMDD default value is 0	R	U32
67 + 68	sensor sensitivity history 2	see register 63 + 64	R	float
69 + 70	calibration date history 2	see register 65 + 66	R	U32

71 + 72	sensor sensitivity history 3	see register 63 + 64	R	float
73 + 74	calibration date history 3	see register 65 + 66	R	U32
75 + 76	sensor sensitivity history 4	see register 63 + 64	R	float
77 + 78	calibration date history 4	see register 65 + 66	R	U32
79 + 80	sensor sensitivity history 5	see register 63 + 64	R	float
81 + 82	calibration date history 5	see register 65 + 66	R	U32
83 + 84	factory use			
85	factory use			
86	temperature response	in x 0.01 %	R	S16
87 + 88	polynomial temperature coefficient a		R	float
89 + 90	polynomial temperature coefficient b		R	float
91 + 92	polynomial temperature coefficient c		R	float
93 + 94	temperature response characterization measurement date	temperature response characterization measurement date of the sensor in YYYYMMDD	R	U32
95	temperature response characterization measurement employee		R	U16
96 + 97	factory use only			
98	humidity (RH)	ln x 0.01 %	R	U16
99	humidity temperature	ln x 0.01 °C	R	S16

100-136	factory use			
137	pressure	in x (1/32) mbar	R	U16
138	pressure average	in x (1/32) mbar	R	U16
139	pressure temperature	in x (1/256) °C	R	S16
140	pressure temperature average	in x (1/256) °C	R	S16
141 - 193	factory use			
194	tilt angle	in x 0.01 °	R	U16
195	tilt angle average	in x 0.01 °	R	U16
196	factory use			
197	factory use			
198	heater current	in x 1 mA	R	U16
199	factory use			



Note 1: Up to five 16 bit registers can be requested in one request. If requesting six or more registers, use multiple requests.

Please note that if your data request needs an offset of +1 for each DR30 register number, depending on processing by the network master, this offset applies to coils as well. Consult the manual of the device acting as the local master.

Table 10.13.3 Coils.

Coils				
coil	parameter	description	type of	object type
0	restart	restart the sensor	W	single bit
1	heater	turn heater on/off	W	single bit
2	check	measure sensor electrical resistance	W	single bit
3	factory use			

10.14 EU declaration of conformity

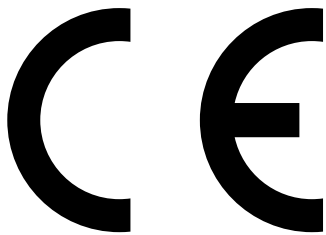

We, **Hukseflux Thermal Sensors B.V.**,
Delftechpark 31, 2628 XI, Delft,
The Netherlands

in accordance with the requirements of the following directives:

2011/65/EU	The Restriction of Hazardous Substances Directive
2014/30/EU	The Electromagnetic Compatibility Directive

hereby declare under our sole responsibility that:

Product models	DR30
Product type	Pyrheliometer
Brand name	Hukx

has been designed to comply and is in conformity with the relevant sections and applicable requirements of the following standards:

Emission	IEC/EN 61000-6-1, Class B, RF emission requirements, IEC CISPR11 and EN 55011 Class B requirements
Immunity	IEC/EN 61000-6-2 and IEC 61326 requirements
Report	"EMC test DR30-D1 203 v15022018", 8 March 2018

Eric HOEKSEMA
Director
Delft, March 14, 2018

About Hukx

Hukx is the leading innovator in solar radiation and heat flux sensor technology. We are proud to set the standard in high-accuracy measurement, and to be working at the heart of the energy transition.

Customers worldwide rely on our bestselling pyranometers and heat flux sensors. From sensor design and selection to supply and recalibration, we support you across the entire lifecycle.

Hukx is headquartered in the Netherlands, with locally owned representative sales offices in the USA, Brazil, India, China, Southeast Asia, and Japan.

Let us help you select the best sensor for your application. Get in touch with our experts today via: info@hukx.com

© Hukx

v2506

We reserve the right to change specifications without prior notice.

www.hukx.com

HUKX